

Base Metal Thermocouples

When ordering Base Metal Thermocouples, please specify the following information:

Calibration:

- Type: J, K

Style:

- Bare element
- Straight element with two-hole insulator
- Dual element with four-hole insulators
- Immersion tip
- Angle type with two-hole insulators
- Base metal with protection (straight or 90°)

Junction:

- Butt welded
- Twisted & welded

AWG Gauge:

- 8, 11, 14, 20

Length (inch):

- 12, 18, 24, 30, 42, 48, 54, 60, 66, 72

Special Options:

- Angle type, specify hot leg and cold leg dimensions
- Immersion tip style (for use in nonferrous molten metals)

Bare Element Style

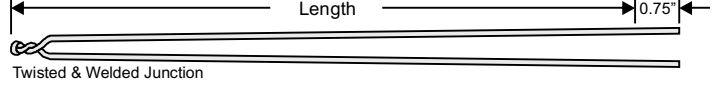

Straight Element Style with Two-Hole Insulators

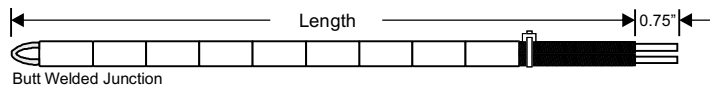
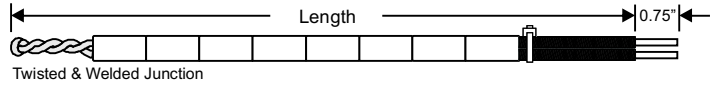

Dual Element Style with Four-Hole Insulators

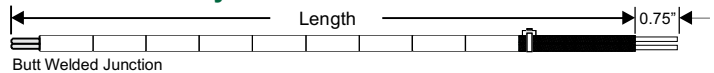

Immersion Tip Style



Angle Style with Two-Hole Insulators

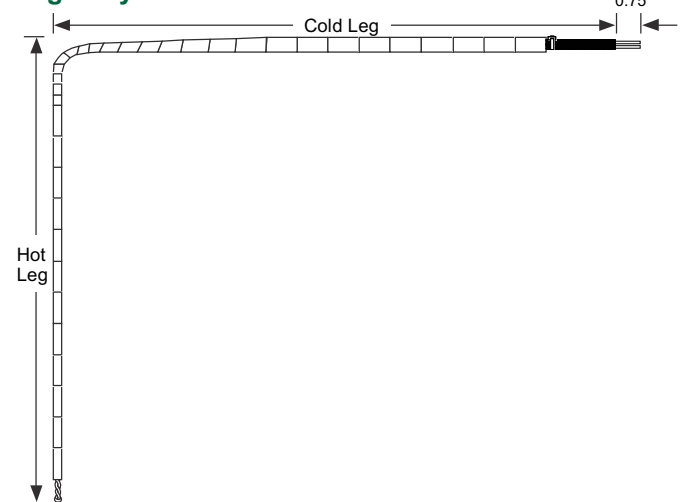

Base Metal with Protection

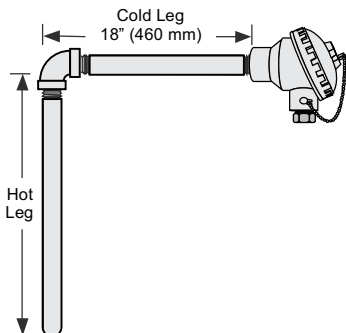
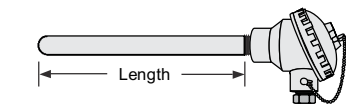

ZESTA ENGINEERING LTD.

Ontario (Head Office)
212 Watline Ave
Mississauga ON, L4Z 1P4
T: (905) 568-3100
F: (905) 568-3131

Québec
2337 rue Guénette
St. Laurent QC, H4R 2E9
T: (514) 334-4744
F: (514) 334-0834

Alberta
4754-14 Street NE
Calgary AB, T2E 6L7
T: (403) 291-1156
F: (403) 291-2630

British Columbia
55B Fawcett Road
Coquitlam BC, V3K 6V2
T: (604) 525-7071
F: (604) 525-7797

info@zesta.com