



# Eurotherm®

Expertise in Improving Process Efficiency,  
Product Quality, and Minimizing Waste

## 3200 Series Temperature/Process Controllers

### Benefits

The innovative range of 3200 controllers offer precision control of temperature and other process variables together with many advanced features not normally found in this class of controller.

- Precision Auto-tuning Eurotherm PID control
- Optional 8 step profiler/programmer
- Very simple to set up and use with quick codes and configurable menu lists

### Key features

- 8 Segment programmer
- Heater failure detection
- Current monitoring
- Customizable Operator messages
- Recipes
- Modbus communications
- Analog and digital retransmission
- Remote setpoint
- Type approved EN14597 TR, EAC, CCC (Exempt)
- Multi-language support (English, French, German, Spanish and Italian)

[eurotherm.com/3200](http://eurotherm.com/3200)

 **WATLOW®**  
Powered by Possibility

# 3200 Series Temperature/Process Controllers Specification

The emphasis of the 3200 Series Temperature/Process Controller is on ease of use. A simple “Quick Start” code is used to configure all the functions essential for controlling your process. This includes input sensor type, measurement range, control options, and alarms, making “Out the Box” operation truly achievable. In operator mode, every parameter has a scrolling text message describing its function and is available in English, German, French, Spanish or Italian. More advanced features are configured using Eurotherm iTools, a PC-based configuration wizard which is an easy to use and instructive guide to all the functions in the controller.

## Heater Current Monitoring

A current transformer input provides display of the heater current and a health check on the load. Heater diagnostics including full and partial open circuit, and short circuit are displayed as scrolling alarm messages as well as providing an alarm output. On the 3208 and 3204 a front panel ammeter displays the heater current.

## Setpoint Programmer

Heat treatment profiles can be programmed using the 8-segment programmer. Holdback (“guaranteed soak”) can be used at the beginning of each segment. A digital event output can be triggered in any segment to initiate actions within the process.

## Custom Text Messaging

Custom messages can be created with Eurotherm iTools and downloaded to the 3200 controller to display when an event, alarm or process condition occurs. This provides the operator with good visibility of the status of the process.

## Remote Setpoint

An option exists for the 3200 controller to have a Remote Analog Input. This can be either volts or mA and is used to allow the setpoint to be generated by a master controller or PLC.

## Recipes

Using Eurotherm iTools, recipes can be created that may be used to change the operating parameters of the 3200 controller simply by selecting a new recipe using the HMI or digital input. This is very useful where multiple products are processed using the same controller but require different parameters to be set.

## Timer

An internal timer is configurable as an interval timer, delay timer, or to provide a soft start for hot runner control.

## Setpoint Retransmission

Sending the setpoint or other parameters from the 3200 controller to slave devices can be achieved either by using conventional analog communications or using Master Modbus communications. Master Modbus in the 3200 controller allows a broadcast of a single parameter to the network.

A typical application is a setpoint being retransmitted to a number of slave controllers in a multi-zone furnace.

## Modbus Communications

All units support both EIA232 and 2-wire EIA485 communications using the Modbus protocol. The 3216 supports 4-wire EIA485.

## Configuration Adaptor

Eurotherm iTools configuration to all 3200 controllers can be achieved by using a USB configuration adaptor. It provides Eurotherm iTools with the ability to communicate with and

configure devices without the need for any power being connected.



## Eurotherm iTools Wizard

Used to simplify the set up of 3200 series controllers. The wizard guides the user through the configuration process with interactive help and graphical demonstrations of features.

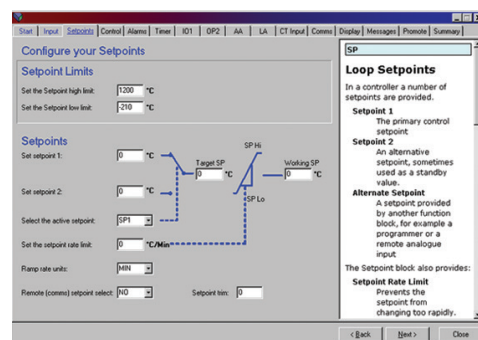



# 3200 Series Temperature/Process Controllers Specification

General	
Environmental Performance	
Temperature limits	Operation: 0 to 55°C Storage: -10 to 70°C
Humidity limits	Operation: 5 to 90% RH non condensing Storage: 5 to 90% RH non condensing
Panel sealing	IP65, Nema 12 / NEMA 4X (3216 only)
Shock	BS EN61010
Vibration	2 g peak, 10 to 150 Hz
Altitude	<2000 metres
Atmospheres	Not suitable for use in explosive or corrosive atmosphere*
EEPROM	Rated lifetime 100,000 write operations

Electromagnetic Compatibility (EMC)	
Emissions and immunity	BS EN61326

Electrical Safety	
BS EN61010	Installation cat. II; Pollution degree 2
INSTALLATION CATEGORY II The rated impulse voltage for equipment on nominal 230V mains is 2500V.	
POLLUTION DEGREE 2 Normally, only non-conductive pollution occurs. Occasionally, however, a temporary conductivity caused by condensation shall be expected.	
EN14597 TR APPROVAL Registration Number TR1229.	

Operator Interface	
Type	LCD TN with backlight
Main PV display	4 digits, green
Lower display	3216, 3208, 3204: 5 character starburst, green 32h8: 9 character starburst, green
Status beacons	Units, outputs, alarms, active setpoint

Power Requirements	
3216:	100 to 240 V ac, -15%, +10%, 48 to 62 Hz, max 6 W 24 V ac, -15%, +10% 24 V dc, -15% +20% ±5% ripple voltage max 6 W
3208, 32h8, 3204:	100 to 240 V ac, -15%, +10%, 48 to 62 Hz, max 8 W 24 V ac, -15%, +10% 24 V dc, -15% +20% ±5% ripple voltage max 8 W

Approval	
CE, UL, cUL listed (file E57766) May be field calibrated to control instrument accuracy required in AMS2750E EN14597 TR CCC Exempt EAC	

Transmitter PSU (not 3216)	
Rating	24 V dc, >28 mA, <33 mA
Isolation	264 V ac, double insulated

Communications	
Serial Communications Option	
Protocol	Modbus RTU slave Modbus RTU Master broadcast (1 parameter)
Isolation	264V ac, double insulated
Transmission standard	EIA232 or EIA485 (2-wire) EIA485 (4-wire) on 3216 only

Process Variable Input	
Calibration accuracy	<±0.25% of reading ±1LSD (Note 1)
Sample rate	4 Hz (250 ms)
Isolation	264 V ac double insulation from the PSU and communication
Resolution (µV)	<0.5 µV with 1.6 sec filter
Resolution (effective bits)	>17 bits
Linearisation accuracy	< 0.1% of reading
Drift with temperature	<50 ppm (typical) <100 ppm (worst case)
Common mode rejection	48-62 Hz, >-120 dB
Series mode rejection	48-62 Hz, >-93 dB
Input impedance	100 MΩ
Cold junction compensation	>30:1 rejection of ambient change
External cold junction	Reference of 0° C
Cold junction accuracy	<±1° C at 25° C ambient
Linear(process) input range	-10 to 80 mV, 0 to 10 V with 100 KΩ/806 Ω external divider module
Thermocouple types	K, J, N, R, S, B, L, T, C, custom download (Note 2)
Resistance thermometer types	3-wire Pt100 DIN 43760
Bulb current	0.2 mA
Lead compensation	No compensation error for 22 Ω in all leads
Input filter	Off to 59.9 s
Zero offset	User adjustable over full range
User calibration	2-point gain & offset

## Mechanical Details

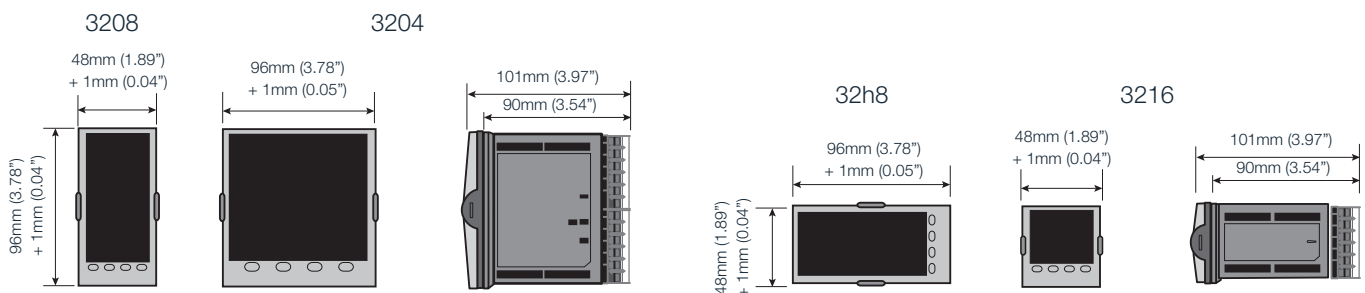

Panel cut out				
	3208	3204	32h8	3216
Cut Out Dimension	92mm (-0.0 +0.8) x 45mm (-0.0 +0.6) 3.62" (-0.0 +0.03") x 1.77" (-0.0 +0.02)	92mm (-0.0 +0.8) x 92mm (-0.0 +0.8) 3.62" (-0.0 +0.03") x 3.62" (-0.0 +0.03)	92mm (-0.0 +0.8) x 45mm (-0.0 +0.6) 3.62" (-0.0 +0.03") x 1.77" (-0.0 +0.02)	45mm (-0.0 +0.6) x 45mm (-0.0 +0.6) 1.77" (-0.0 +0.02") x 1.77" (-0.0 +0.02)
Product Weight	350g 12.34oz	420g 14.81oz	350g 12.34oz	250g 8.81oz

AA Relay	
Type	Form C (changeover)
Rating	Min 100 mA @ 12 V dc, max 2 A @ 264 V ac resistive
Functions	Control outputs, alarms, events

Current Transformer Input	
Input range	0-50 mA rms, 48/62 Hz 10 Ω burden resistor fitted inside module
Calibration accuracy	<1% of reading (typical), <4% of reading (worst case)
Isolation	By using external CT
Input impedance	<20 Ω
Measurement scaling	10, 25, 50 or 100 Amps
Functions	Partial load failure, SSR detected fault

Digital Input (DigIn A/B, B not on 3216)	
Contact closure	Open >600 Ω, closed <300 Ω
Input current	<13 mA
Isolation	None from PV or system 264 V ac double insulated from PSU and communications
Functions	Includes alarm acknowledge, SP2 select, manual keylock, timer functions standby select, RSP select

Logic I/O Module	
Output	
Rating	ON 12 V dc @ <44 mA, OFF <300 mV @ 100 μA
Isolation	None from PV or system 264 V ac double insulated from PSU and communications
Functions	Control outputs, alarms, events

Digital Input	
Contact closure	Open >500 Ω, closed <150 Ω
Isolation	None from PV or system 264 V ac double insulated from PSU and communications
Functions	Includes alarm acknowledge, SP2 select, manual keylock, timer functions standby select, RSP select

Relay Output Channels	
Type	Form A (normally open)
Rating	Min 100 mA @ 12 V dc, max 2 A @264 V ac resistive
Functions	Control outputs, alarms, events

Triac Output	
Rating	0.75 A (rms) 30 to 264 V (rms) resistive load
Isolation	264 V ac double insulated
Functions	Control outputs, alarms, events

Analog Output (Note 3)	
OP1, OP2	
Rating	0-20 mA into <500 Ω
Accuracy	± (<1% of Reading + <100 μA)
Resolution	13.5 bits
Isolation	264 V ac double insulated from PSU and comms Module code C provides full 264 V ac double isolated
Functions	Control outputs, retransmission

OP 3 (not on 3216)	
Rating	0-20 mA into <500 Ω
Accuracy	±(<0.25% of Reading + <50 μA)
Resolution	13.6 bits
Isolation	264 V ac double insulated
Functions	Control outputs, retransmission

Remote Setpoint Input	
Calibration accuracy	<±0.25% or reading ±1LSD
Sample rate	4 Hz (250 ms)
Isolation	264 V ac double insulation from instrument
Resolution	<0.5 mV (for 0-10 V) or <2 μA (for 4-20 mA)
Resolution (effective bits)	>14 bits
Drift with temperature	<50 ppm (typical) <150 ppm (worst case)
Common mode rejection	48-62 Hz, >-120 dB
Series mode rejection	48-62 Hz, >-90 dB
Input impedance	Voltage: 223 KΩ and Current: 2R49
Normal input range:	0 to 10 V and 4 to 20 mA
Max input range	-1 V to 11 V and 3.36 mA to 20.96 mA

Software Features	
Control	
Number of loops	1
Loop update	250ms
Control types	PID, ON/OFF, VP
Cooling types	Linear, fan, oil, water
Modes	Auto, manual, standby, forced manual
Overshoot inhibition	High, low

Alarms	
Number	4
Type	Absolute high & low, deviation high, low or band, rate of change
Latching	Auto or manual latching, non-latching, event only
Output assignment	Up to 4 conditions can be assigned to one O/P

Other Status Outputs	
Functions	Including sensor break, manual mode, timer status, loop break, heater diagnostics, program event
Output assignment	Up to 4 conditions can be assigned to one O/P

Setpoint Programmer	
Program function	1 program x 8 segments with 1 event output (Note 4)
Start mode	Servo from PV or SP
Power fail recovery	Continue at SP or Ramp back from PV
Holdback ("Guaranteed soak")	Inhibits dwell timing until PV within limits

Timer	
Modes	Dwell when setpoint reached Delayed control action Soft start limits power below PV threshold

Current Monitor	
Alarm types	Partial load failure, over current, SSR short circuit, SSR open circuit
Indication type	Numerical or ammeter

Custom Messages	
Number	15 scrolling text messages
No of characters	127 characters per message max
Languages	English, German, French, Spanish, Italian
Selection	Active on any parameter status using conditional command

Recipes	
Number	15 scrolling text messages
Selection	HMI interface, communications or digital I/O

#### Notes

1. Calibration accuracy quoted over full ambient operating range and for all input linearization types.
2. Contact Eurotherm for details of availability of custom downloads for alternative sensors.
3. Voltage output can be achieved by external adaptor.
4. By using recipes five SP programs can be stored.

# Order Code Hardware/Options Coding



Basic Product	
3216	48 x 48mm unit
3208	48 x 96mm unit
32h8	96 x 48mm horizontal unit
3204	96 x 96mm unit

1 Function	
CC	Standard controller
CP	Standard programmer
VC	Motorized valve controller
VP	Motorized valve programmer

2 Supply Voltage	
VH	85-264 V AC
VL	24 V AC/DC

3 Outputs			
3216			
	OP1	OP2	
XXXX	None fitted	None fitted	
LXXX	Logic	None fitted	
LRXX	Logic	Relay	
RRXX	Relay	Relay	
LLXX	Logic	Logic	
LDX	Logic	0-20 mA	
DDXX	0-20 mA	0-20 mA	
DRXX	0-20 mA	Relay	
RCXX	Relay	Isolated 0-20 mA	
LCXX	Logic	Isolated 0-20 mA	
DCXX	0-20 mA	Isolated 0-20 mA	
LTX	Logic	Triac	
TXX	Triac	Triac	
3208/32h8/3204			
	OP1	OP2	OP3
LRRX	Logic	Relay	Relay
RRRX	Relay	Relay	Relay
LLRX	Logic	Logic	Relay
LRDX	Logic	Relay	0-20 mA
RRDX	Relay	Relay	0-20 mA
DDDX	0-20 mA	0-20 mA	0-20 mA
LLDX	Logic	Logic	0-20 mA
LDDX	Logic	0-20 mA	0-20 mA
DRDX	0-20 mA	Relay	0-20 mA
Not available with Low Voltage PSU			
LTRX	Logic	Triac	Relay
TTRX	Triac	Triac	Relay
LTDX	Logic	Triac	0-20 mA
TDDX	Triac	0-20 mA	0-20 mA
TTDX	Triac	Triac	0-20 mA

4 AA Relay (OP4)	
X	Not fitted
R	Relay

5 Options Board	
XXX	Not fitted
XXL	Logic input
XCL	CT + Logic IP
2XL	RS232 Comms + Logic IP
4XL	2-wire RS485 comms + Logic IP
2CL	RS232 Comms CT + Logic IP
4CL	2-wire RS485 Comms CT + Logic IPP
RCL	Remote SP CT + Logic IP

8 Manual Language	
ENG	English
FRA	French
GER	German
SPA	Spanish
ITA	Italian

9 Warranty	
XXXXX	Standard
WL005	Extended

10 Certificates	
XXXXX	None
CERT1	Certificate of Conformity
CERT2	Factory Calibration certificate

6 Fascia Color	
G	Green
S	Silver
W	Washdown (not 32h8/04)

11 Custom Label	
XXXXX	None

7 Product Language	
ENG	English
FRA	French
GER	German
SPA	Spanish
ITA	Italian

12 Specials and Accessories	
XXXXX	None
RES250	250R resistor for 0-5 V DC OP
RES500	500R resistor for 0-10 V DC OP

## 3200 Controller Accessories

HA029714	Installation guide
HA027986	Engineering manual
SUB35/ACCESS/249R.1	2.49R Precision resistor
CTR100000/000	10 A Current transformer
CTR200000/000	25 A Current transformer
CTR400000/000	50 A Current transformer
CTR500000/000	100 A Current transformer
ITTOOLS/NONE/USB	USB configuration kit
SUB21/IV10	0-10 V input adaptor

## 3208/32h8/3204 Isolation

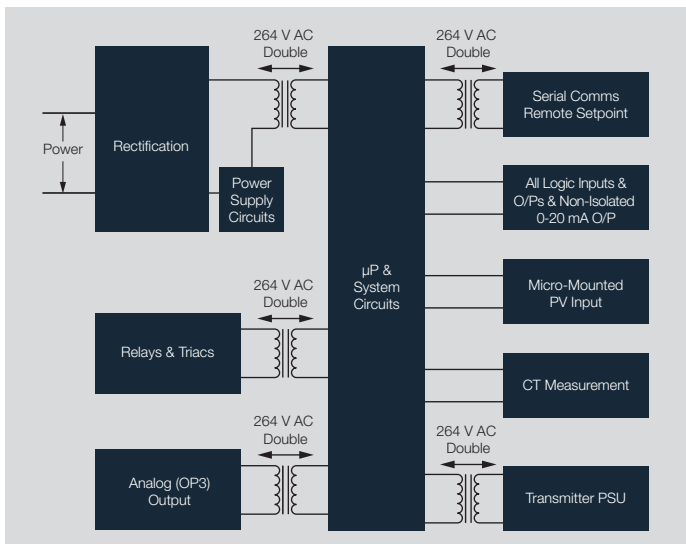

## 3216 Isolation

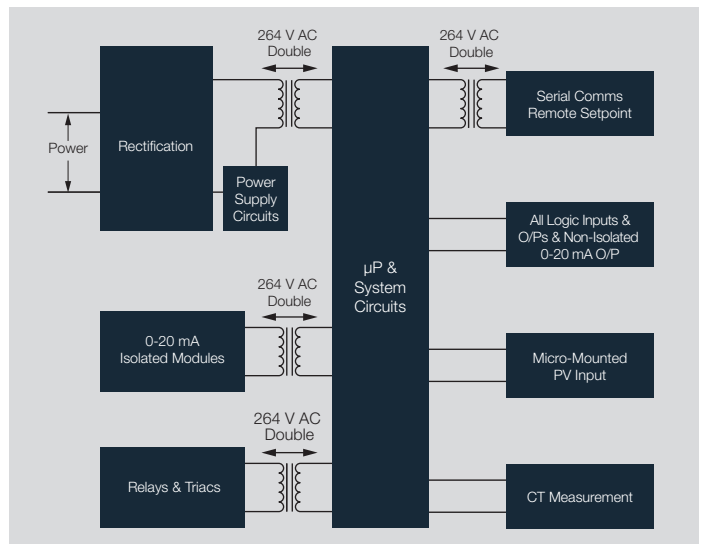

# Optional Quick Start Code (Optional)

1	2	3	4	5	6	7	8 3208/h8 /04 only	9 3208/h8 /04 only	10
---	---	---	---	---	---	---	--------------------------	--------------------------	----

1 Input Type	
Thermocouple	
B	Type B
J	Type J
K	Type K
L	Type L
N	Type N
R	Type R
S	Type S
T	Type T
C	Custom/Type C
RTD	
P	Pt100
Linear	
M	0-80 mV
2	0-20 mA
4	4-20 mA
X	Unconfigured

2 Setpoint Limits	
Full PV Range	
C	Deg C full range
F	Deg F full range
Centigrade	
0	0 to 100 deg C
1	0 to 200 deg C
2	0 to 400 deg C
3	0 to 600 deg C
4	0 to 800 deg C
5	0 to 1000 deg C
6	0 to 1200 deg C
7	0 to 1400 deg C
8	0 to 1600 deg C
9	0 to 1800 deg C
Fahrenheit	
G	2 to 212 deg F
H	32 to 392 deg F
J	32 to 752 deg F
K	32 to 1112 deg F
L	32 to 1472 deg F
M	32 to 1832 deg F
N	32 to 2192 deg F
P	32 to 2552 deg F
R	32 to 2912 deg F
T	32 to 3272 deg F
X	Unconfigured

3 Output 1 (OP1)	
XX	Unconfigured
Relay, DC, Triac or Logic outputs	
Control	
H	Heat (PID)
C	Cool (PID)
J	Heat (on/off)
K	Cool (on/off)
Alarm Output	
Energized in alarm	
0	High alarm
1	Low alarm
2	Deviation high
3	Deviation low
4	Deviation band
Alarm Output	
De-energized in alarm	
5	High alarm
6	Low alarm
7	Deviation high
8	Deviation low
9	Deviation band
DC Outputs	
Control	
H	4-20 mA heating
C	4-20 mA cooling
J	0-20 mA heating
K	0-20 mA cooling
Retransmission	
D	4-20 mA setpoint
E	4-20 mA process value
F	4-20 mA output
N	0-20 mA setpoint
Y	0-20 mA process value
Z	0-20 mA output
Logic Input	
W	Alarm acknowledge
M	Manual select
R	Timer/Prog Run
L	Keylock
P	Setpoint 2 select
T	Timer/prog Reset
U	Remote SP select
V	Recipe 2/1 select
A	Remote up button
B	Remote down button
G	Time/prog Run/reset
I	Timer/prog Hol
Q	Standby select

4 Output 2 (OP2)	
XX	Unconfigured
Relay, DC, Triac or Logic Outputs	
Control	
H	Heat (PID)
C	Cool (PID)
J	Heat (on/off)
K	Cool (on/off)
Alarm Output	
Energized in alarm	
0	High alarm
1	Low alarm
2	Deviation high
3	Deviation low
4	Deviation band
Alarm Output	
De-energized in alarm	
5	High alarm
6	Low alarm
7	Deviation high
8	Deviation low
9	Deviation band
DC Outputs	
Control	
H	4-20 mA heating
C	4-20 mA cooling
J	0-20 mA heating
K	0-20 mA cooling
Retransmission	
D	4-20 mA setpoint
E	4-20 mA process value
F	4-20 mA output
N	0-20 mA setpoint
Y	0-20 mA process value
Z	0-20 mA output

5 AA Relay (OP4)	
XX	Unconfigured
Relay, DC, Triac or Logic Outputs	
Control	
H	Heat (PID)
C	Cool (PID)
J	Heat (on/off)
K	Cool (on/off)
Alarm Output	
Energized in Alarm	
0	High alarm
1	Low alarm
2	Deviation high
3	Deviation low
4	Deviation band
Alarm Output	
De-Energized in Alarm	
5	High alarm
6	Low alarm
7	Deviation high
8	Deviation low
9	Deviation band

6 CT Input Scaling	
XX	Not fitted
1	10 Amps
2	25 Amps
5	50 Amps
6	100 Amps

7-8 Dig Input A, Dig Input B	
X	Unconfigured
W	Alarm acknowledge
M	Manual select
R	Timer/Prog Run
L	Keylock
P	Setpoint 2 select
T	Timer/prog Reset
U	Remote SP select
V	Recipe 2/1 select
A	Remote up button
B	Remote down button
G	Time/prog Run/reset
I	Timer/prog Hold
Q	Standby select

9 Output 3 (OP3)	
XX	Unconfigured
Relay, DC, Triac or Logic Outputs	
Control	
H	Heat (PID)
C	Cool (PID)
J	Heat (on/off)
K	Cool (on/off)
Alarm Output	
Energized in Alarm	
0	High alarm
1	Low alarm
2	Deviation high
3	Deviation low
4	Deviation band
Alarm Output	
De-Energized in Alarm	
5	High alarm
6	Low alarm
7	Deviation high
8	Deviation low
9	Deviation band
DC Outputs	
Control	
H	4-20 mA heating
C	4-20 mA cooling
J	0-20 mA heating
K	0-20 mA cooling
Retransmission	
D	4-20 mA setpoint
E	4-20 mA process value
F	4-20 mA output
N	0-20 mA setpoint
Y	0-20 mA process value
Z	0-20 mA output

10 Lower Display	
X	Unconfigured
T	Setpoint
S	Target setpoint
P	Output power %
R	Time remaining
E	Elapsed time
1	1 <sup>st</sup> alarm setpoint
D	Dwell/ramp — time/target
C	SP with output meter
M	SP with ammeter
A	Load amps
N	None

# 3200 Series Temperature/Process Controllers Specification

## Rear Terminals

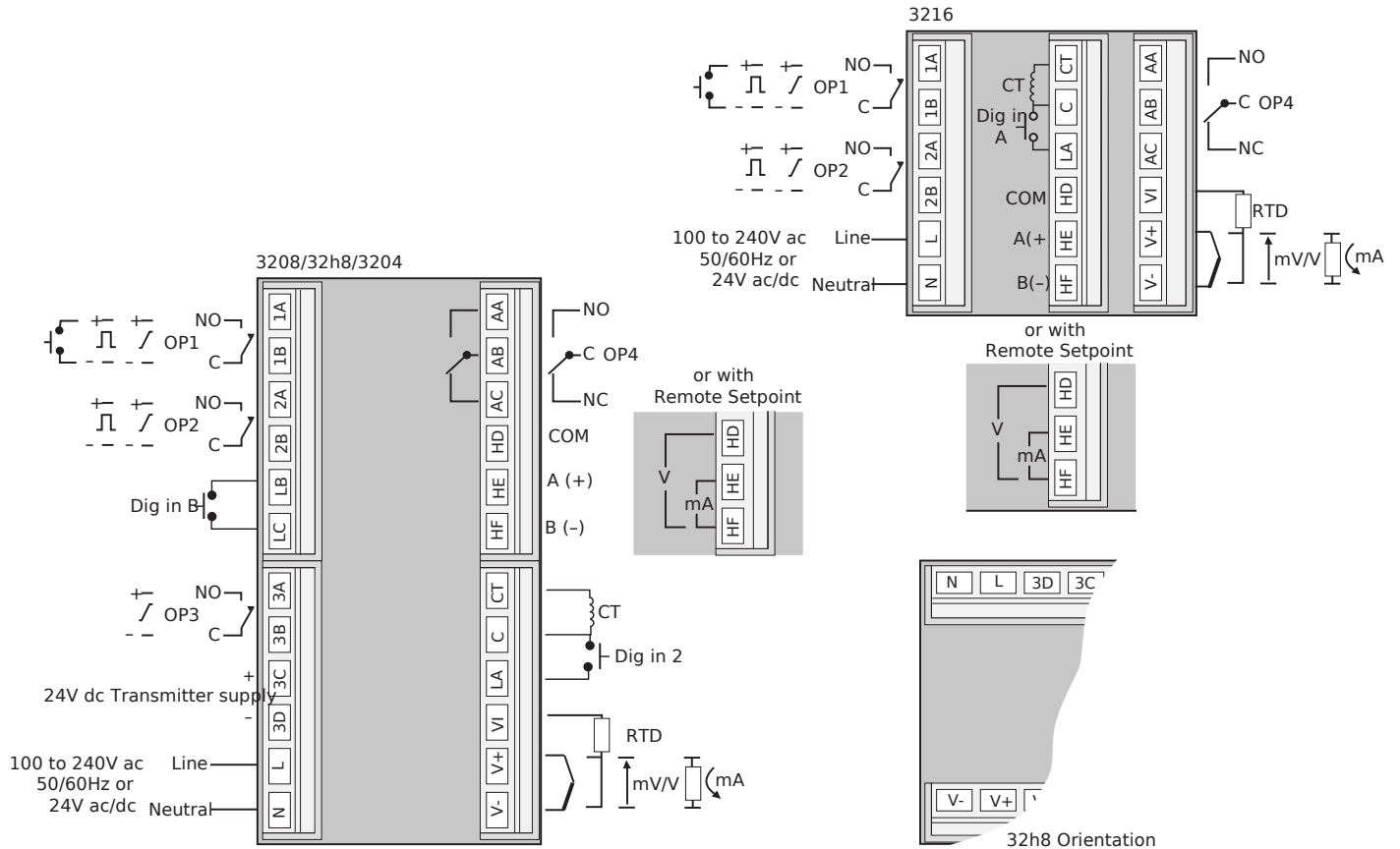

Eurotherm  
Faraday Close, Worthing,  
West Sussex, BN13 3PL  
United Kingdom  
Phone: + 44 (0)1903 268500

[www.eurotherm.com](http://www.eurotherm.com)

Document Number HA028600 Issue 14

Watlow, Eurotherm, EurothermSuite, EFit, EPack, EPower, Eyon, Chessell, Mini8, nanodac, piccolo and versadac are trademarks and property of Watlow its subsidiaries and affiliated companies. All other trademarks are the property of their respective owners.

©Watlow Electric Manufacturing Company. All rights reserved.

Your Authorized Distributor is:



**ZESTA**  
Industrial Thermal Technologies

ZESTA ENGINEERING LTD.  
212 Watline Avenue  
Mississauga ON, L4Z 1P4

1-800-755-5418 ▪ [www.zesta.com](http://www.zesta.com) ▪ [info@zesta.com](mailto:info@zesta.com)  
Mississauga, ON ▪ Montréal, QC ▪ Calgary, AB ▪ Vancouver, BC

