

CAST-X 500

Circulation Heater

CAST-X 500 is very compact, easily integrated into larger machines, medical devices and laboratories.



Designed and manufactured by Cast Aluminum Solutions (CAS), CAST-X Circulation Heaters are engineered using the latest thermal modeling and finite element analysis technology. CAST-X heaters feature low-watt-density heating elements cast into aluminum bodies which also contain the helical-coiled stainless steel flowpath tubes.

The media is sequestered in these tubes, never touching the heating elements: a critical safety benefit, especially when heating explosive or sensitive media. All CAST-X units are capable of heating liquids and gases alike.

CAST-X heaters are self-draining, for safety and cleanliness. With compact, non-welded bodies, plus NEMA & ATEX enclosures, CAST-X units are small-footprint, high-output heaters that meet the needs of high-purity processes, flammable operations, and your most critical heating applications.

APPLICATIONS:

- Ink Heating for Commercial Printing
- Analytical Instrumentation Sample Heating
- Commercial & Consumer Appliances
- Pre-Heating of Oils
- Laboratory Applications
- Heating of Beverages & Food Industry Liquids
- Medical Device Applications



SPECIFICATIONS:

- Power:
 - Up to 1500 W
 - Voltage Range: 110 - 240 V
 - Max Line Current: 12.5 A
 - Tubing:
 - .250" OD (1/4") (6.3 mm)
 - .028" Wall (.7 mm)
 - Overall Process Tube Length: 84" (2133 mm)
 - 316L Stainless Steel (standard)
 - Inconel (optional upgrade)
 - Passivated or Electro-Polished (optional upgrades)
 - Max Pressure: 3200 psi (220 bar)
 - Enclosures:
 - No Enclosure
 - NEMA 1 (general-purpose/dust-proof)
 - NEMA 4 (moisture-resistant)
 - NEMA 7 (explosion-proof)
 - Max Working Temperatures:
 - No Enclosure: 392°F (200°C)
 - NEMA 1 (dust-proof/general-purpose): 250°F (121°C)
 - NEMA 4 (moisture-resistant): 250°F (121°C)
 - NEMA 7 (explosion-proof): 392°F (200°C)
- Published temperatures are for housing at 12 o'clock position; higher temps may be possible at 6 o'clock position. See factory for details.
- Sensors:
 - K or J Type Thermocouples Standard
 - Snap-Action High-Limit Thermostat (no housing)
 - Available Accessories:
 - Insulating Jackets
 - Compression Fittings

FEATURES & BENEFITS:

- SS 316L Fluid Path is Separate from Heating Elements (allows safe heating of sensitive materials and prevents contamination)
- Compatible with High Pressure Applications
- Self-Draining, to Reduce Material Entrapment
- Long-Lifespan, Low-Maintenance Design
- Non-Welded Construction Virtually Eliminates Leakage
- Quick Heating Response Due to Low Mass
- Small Size Enables Easy Integration into Larger Machines

CAST-X 500 Circulation Heater

NO ENCLOSURE

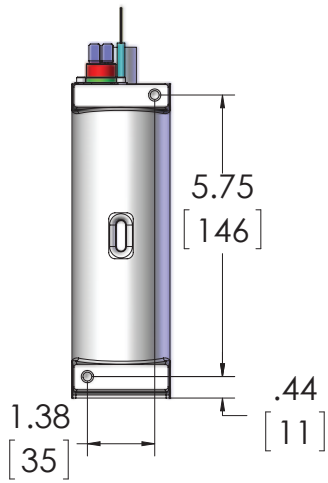

NO ENCLOSURE

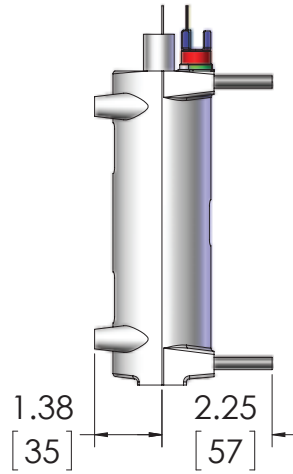

NO ENCLOSURE

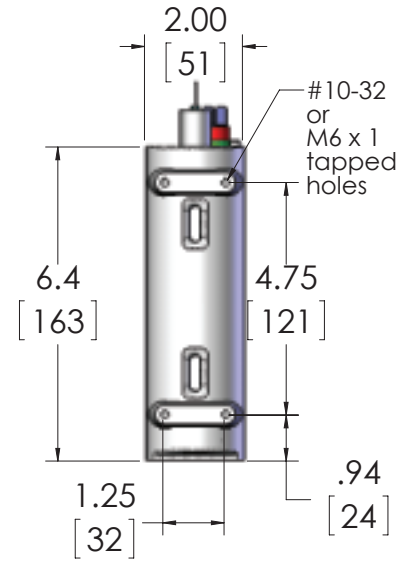

CAST-X 500 Heating Profile: Delta-T Water

(Process Fluid = Water @ 42°F / 5.6°C Inlet Temp, Single Pass, 100% Power, Set Point 752°F / 400°C)

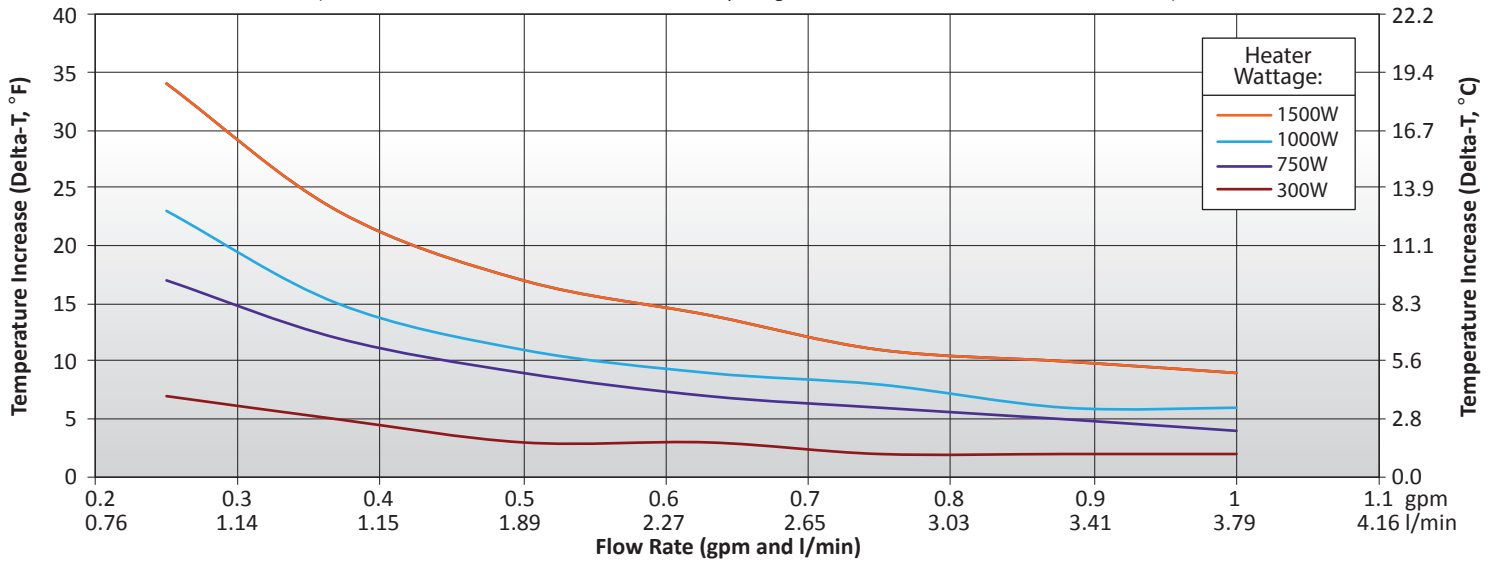

CAST-X 500 Pressure Drop Profile: Delta-P Water

(Process Fluid = Water. Change in Pressure from Inlet to Outlet, Single Pass)

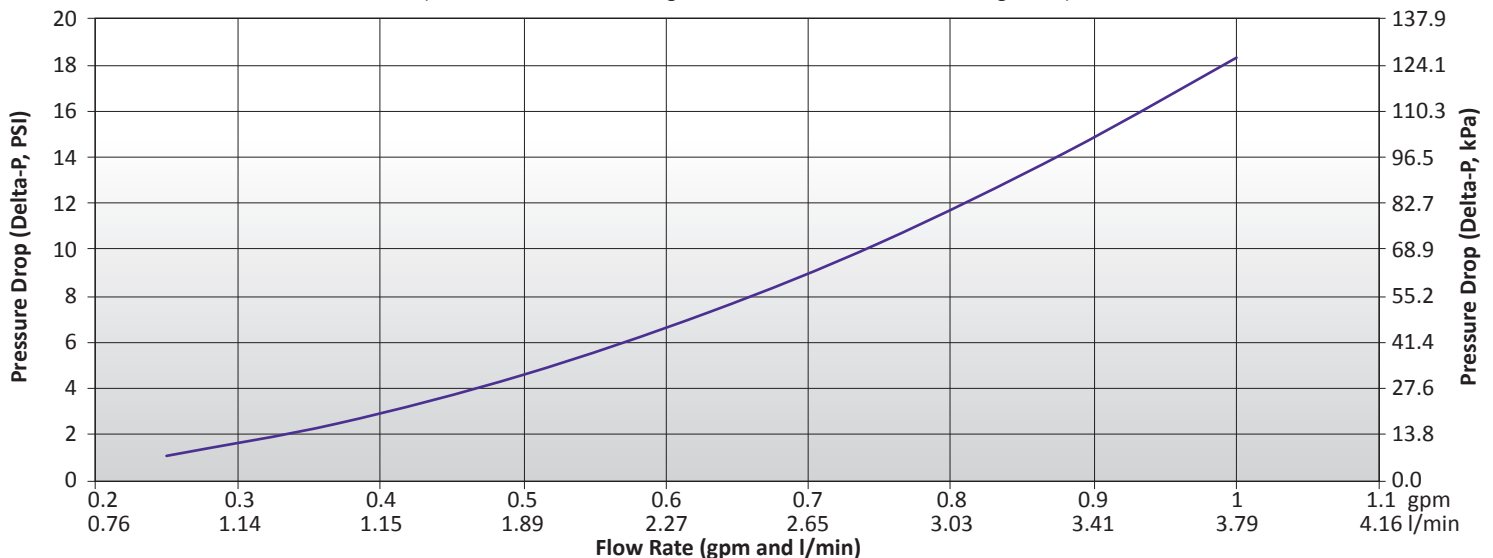

**GENERAL-PURPOSE (NEMA 1) AND
MOISTURE-RESISTANT (NEMA 4) ENCLOSURE**

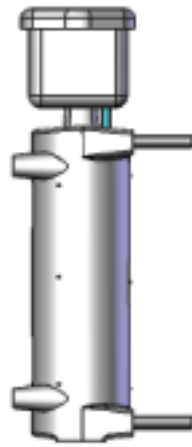
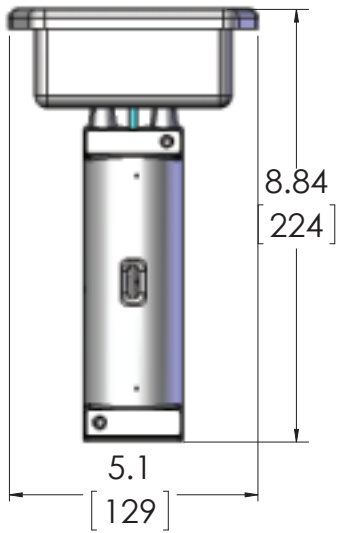

EXPLOSION-PROOF (NEMA7) ENCLOSURE

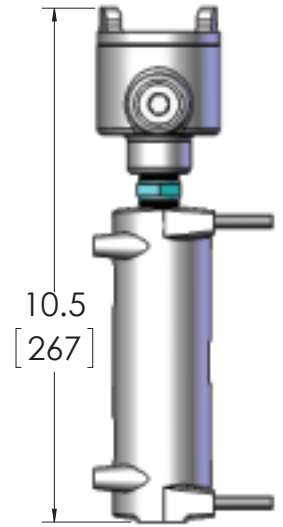

CAST-X 500 Heating Profile: Delta-T Air

(Process Fluid = Air @ 100 psi (689 kPa), 70.7°F / 21.5°C, Single Pass, Set Point 752°F / 400°C)

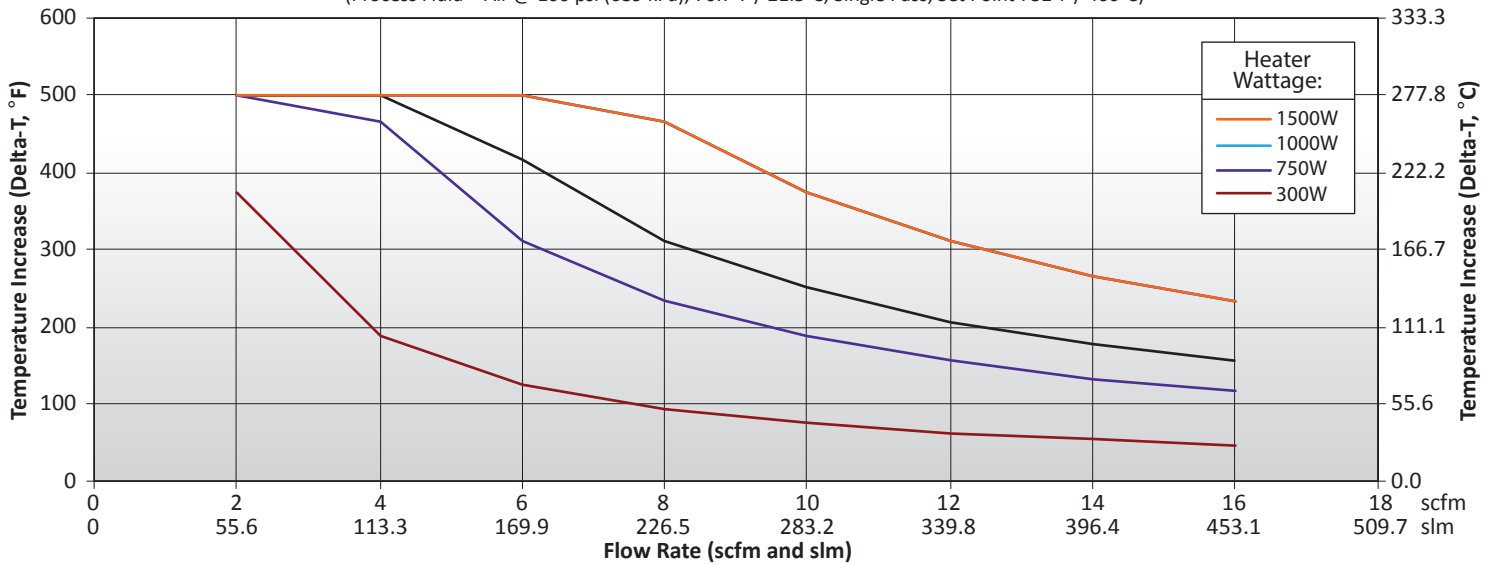

CAST-X 500 Heating Profile: Delta-P Air

(Process Fluid = Air @ 100 psi (689 kPa), 70.7°F / 21.5°C, Single Pass, Set Point 752°F / 400°C)

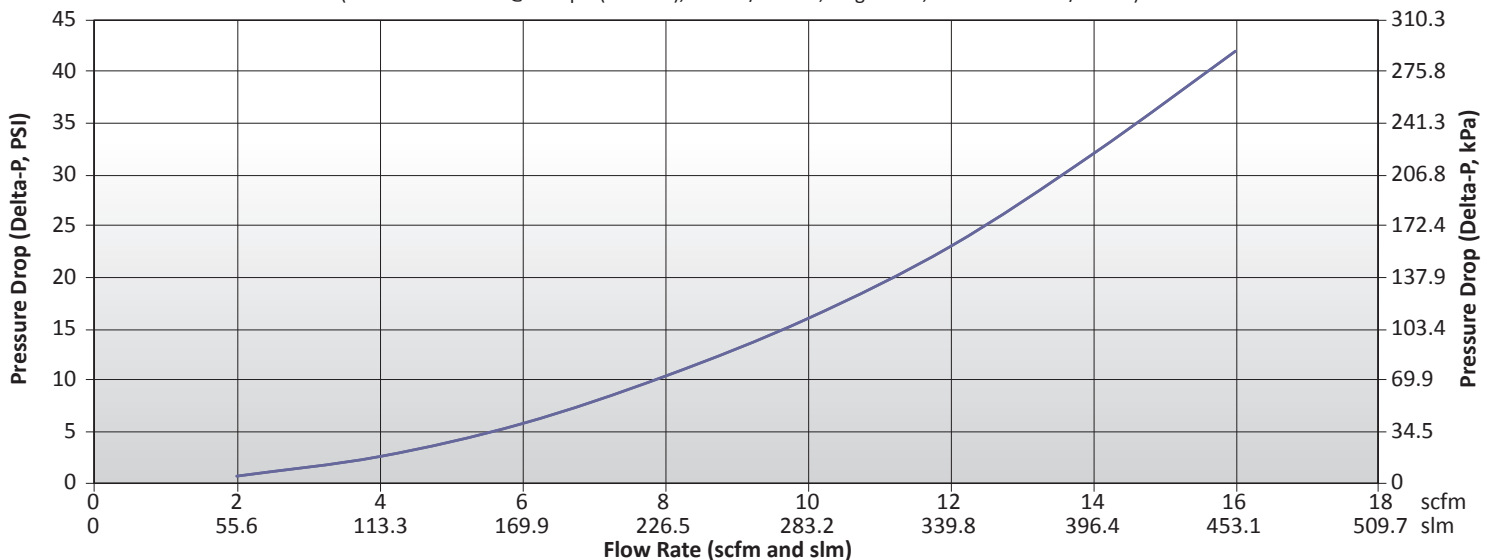

CAST-X 500 Circulation Heater

Engineering Expertise • Speed to Market • Operational Excellence

Cast Aluminum Solutions (CAS) manufactures the CAST-X line of circulation heaters, plus a broad range of heating, cooling, and non-thermal components. We are relied upon by OEMs and end-users alike throughout the semiconductor, medical device, aerospace, industrial gas, fluid-handling, food equipment, and energy markets.

Our multi-discipline team of engineers and technicians works closely with customers to develop practical solutions to complex process challenges. We utilize industry standard applications such as Finite Element Analysis (FEA), SolidWorks® 3-D CAD technology, and a range of structural analysis & thermal modeling tools.

CAS is an ISO 9001 Certified company with a fully-equipped R&D facility. Testing capabilities include X-Ray, ultrasound, helium leak, and infra-red technology, plus the latest coordinate measuring machines (CMM). Our in-house casting facility utilizes a permanent mold low-pressure casting process which reliably produces low-porosity, high-quality aluminum products. We offer an array of precision CNC machining options, finishing options such as electroless nickel plating, Teflon® coatings, clear-coat and hard-coat anodizing, plus high-value-added testing and inspection services.

Headquartered in Batavia, Illinois (just outside Chicago) we serve customers worldwide.

See the below map to locate a Sales Engineer, or contact CAS directly. We look forward to working with you.

With offices worldwide, the CAS Team of knowledgeable and experienced representatives is ready to assist with your project.

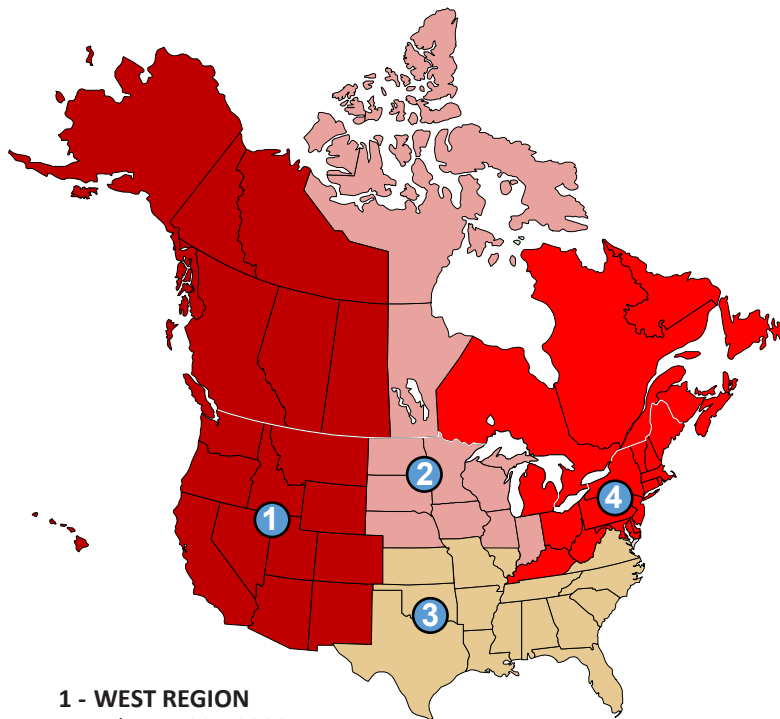

1 - WEST REGION

Tel: 714-935-2999

2 - MIDWEST REGION

Chicago Tel: 847-458-1500
Minneapolis Tel: 952-892-9222

3 - SOUTH REGION

Tel: 678-951-8120

4 - NORTHEAST REGION

Tel: 513-398-5500

ENERGY PROCESS DIVISION

Tel: 866-948-1708

SEMICONDUCTOR DIVISION

Tel: 408-754-3370

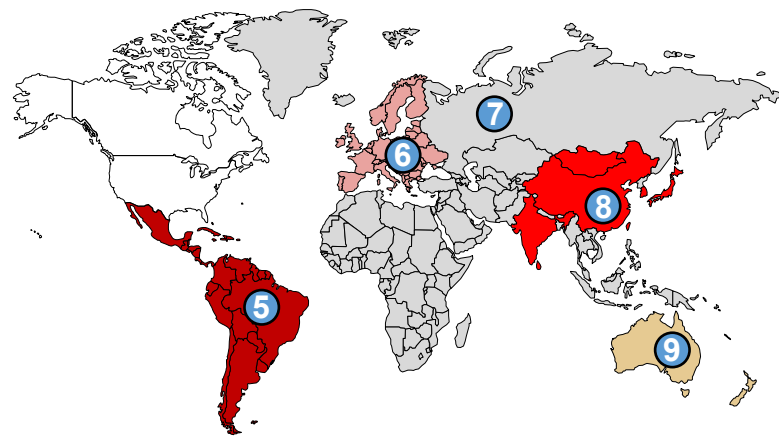

**5 - MEXICO, CENTRAL
and SOUTH AMERICA**
Tel: +52 442-256-2200

6 - EUROPE
France
Tel: +33 (0) 1-41-32-79-70

Germany
Tel: +49 7253-9400-0

Italy
Tel: +39 02-458-8841

Spain
Tel: +34 91-675-1292

United Kingdom
Tel: +44 115-964-0777

7 - RUSSIA, AFRICA & MIDDLE-EAST
Tel: +1 630-879-2696

8 - ASIA
China
Tel: +86 21-3532-8532

Japan
Tel: +81 3-3518-6630

Korea
Tel: +82 2-2169-2600

Taiwan
Tel: +866 7-288-5168

India
Tel: +91 40-666-12700

9 - AUSTRALIA & NZ
Tel: +61 3-9335-6449



WX6E2A AAAA-BBCC-D

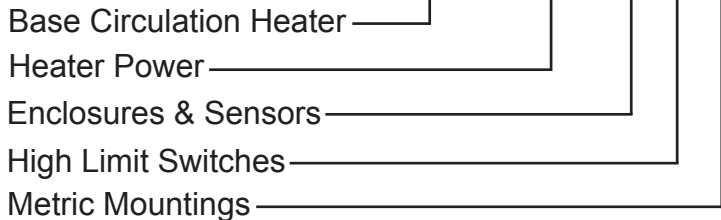

Building a CAST-X 500 Part Number

Use the graphs below to build your CAST-X 500. Assigning numbers for sections AAAA, BB and CC. If you need metric mountings, assign "M" to section D. If metric mounts are not required, leave section D blank. For assistance, contact CAS directly.

VOLTAGE, POWER, CIRCUIT TYPE				
<i>Volts refers to line volts (V_L). Amps refers to line current (I_L).</i>				
Section "AAAA"	Volts (V)	Watts (W)	Circuit Type (all are single circuit)	Amps (A)
300A	120	300	SINGLE PHASE	2.5
300B	120	1500	SINGLE PHASE	12.5
300C	240	300	SINGLE PHASE	1.6
300D	240	500	SINGLE PHASE	2.1
300E	240	750	SINGLE PHASE	3.1
300F	240	1000	SINGLE PHASE	4.2
300G	240	1200	SINGLE PHASE	5
300H	240	1500	SINGLE PHASE	6.3
300J	208	1125	SINGLE PHASE	5.4
300K	208	900	SINGLE PHASE	4.3
300L	208	750	SINGLE PHASE	3.6
300M	208	565	SINGLE PHASE	2.7

ENCLOSURES AND SENSORS			
<i>All thermocouples are ungrounded, for optimal performance</i>			
Section "BB"	Description	Thermocouple Qty.	Enclosure
00	NO SENSOR	0	NO ENCLOSURE
0J	J-TYPE THERMOCOUPLE IN CASTING	1	NO ENCLOSURE
0K	K-TYPE THERMOCOUPLE IN CASTING	1	NO ENCLOSURE
S0	NO SENSOR	0	NEMA 1
SJ	J-THERMOCOUPLE IN CASTING	1	NEMA 1
SK	K-THERMOCOUPLE IN CASTING	1	NEMA 1
W0	NO SENSOR	0	NEMA 4
WJ	J-TYPE THERMOCOUPLE IN CASTING	1	NEMA 4
WK	K-TYPE THERMOCOUPLE IN CASTING	1	NEMA 4
E0	NO SENSOR	0	NEMA 7
EJ	J-TYPE THERMOCOUPLE IN CARTRIDGE HEATER	1	NEMA 7
EK	K-TYPE THERMOCOUPLE IN CARTRIDGE HEATER	1	NEMA 7

SNAP ACTION HIGH LIMITS SWITCHES	
<i>Available only with "No Enclosure" options</i>	
Section "CC"	Switch
00	NONE
01	MANUAL RESET, 260°F (127°C)
02	AUTOMATIC RESET, 250°F (121°C)

METRIC MOUNTING HOLES	
<i>Place an "M" in section D if metric mounting holes are required. If standard Imperial mounting holes are desired, section D can be left blank</i>	
Section "D"	Metric Mounting Holes
M	M6 X 1.00 METRIC TAPPED MOUNTING HOLES

CUSTOM DESIGNS & COMPONENTS	
<i>CAS offers several options for special tubes, sensors, and finishes. For these options, please call a CAS Representative for a quote.</i>	
Options	
INCONEL, MONEL OR HASTELLOY TUBES	RTDS (RESISTANCE TEMPERATURE DETECTORS)
ELECTRO-POLISHED OR PASSIVATED TUBES	SPECIAL HIGH-LIMIT SWITCHES

ACCESSORIES	
<i>These PNs are totally separate from the PNs for the heater</i>	
Part Number	Component
274-55-6-1	COMPRESSION FITTINGS (HIGH PRESSURE) / PAIR (SHIPPED LOOSE)
307-0-12-1	INSULATION JACKET, MAXIMUM TEMPERATURE 400°F (204°C)

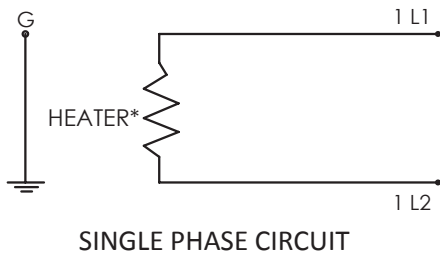

CAST-X 500 Available Circuit Types

The CAST-X 500 is available with a single heating element. The basic heating unit features one internal cartridge heater.

*Wiring schematic only shows heater elements. Refer to I&M Manual for further details on wiring of snap-action switches and thermostats (if applicable).



NO ENCLOSURE OPTION



NEMA 1 AND NEMA 4 ENCLOSURE



NEMA 7 ENCLOSURE

Need Help with Part Numbers or Engineering Calculations?

One of the key advantages of working with CAS is the accessibility of our team and ability to offer assistance. The CAS Team is ready and available to help you work through part number configurations, provide engineering advice, and ensure customers purchase the heater most appropriate for their particular application.

CAS Engineers are accustomed to working closely with customers to generate accurate calculations and models. We have a range of powerful tools at our disposal, including Finite Element Analysis (FEA) software, 3-D CAD applications, and infra-red thermal testing.

Our mission is developing solutions, from concept to reality. So feel free to contact the CAS Team directly:



Main Tel: 630-879-2696
 Toll-Free: 888-367-3992
Sales@CastAluminumSolutions.com
www.CastAluminumSolutions.com