

# Thermocouples

## Surface Temperature Measurement

### TRUE SURFACE Thermocouple (TST)

#### Increase Surface Temperature Accuracy with Improved Thermocouple Design

Watlow's award winning TST offers superior accuracy for measuring flat surface temperatures. This compact, highly accurate sensor isolates the thermocouple junction from ambient airflow. The TST typically achieves accuracy and repeatability of one to two percent ( $\Delta T$ ).

The TST, with its removable molded cover, fits into corners and other tight locations. TSTs are easy to install with a variety of commonly used screw types.

Watlow's TST sensor is ideal for many applications including semiconductor chambers, platens, packaging, cleaning and food preparation.

#### Options

- Dual, isolated thermocouples in the same sensor
- Ungrounded or grounded junction(s)
- Type J or K calibrations
- Shielded lead wire with drain, either isolated from or connected to the sensor sheath (availability limited with dual junctions)



#### Steady State Temperature Measurement Test

- **Purpose:** To determine and compare the steady state error of the Watlow TST and a common "washer"-style thermocouple at several temperature settings with and without ambient airflow.
- **Test Description:** Each sensor was attached to a brass hot plate and allowed to reach equilibrium before temperature readings were taken. Room temperature air was then blown onto the hot plate and the sensors. Temperature readings were taken after the system reached the new equilibrium point. The test was performed with a 20, 40, 60 and 80°C differential between the hot plate temperature and ambient.
- **Results:** Ambient temperature = 25°C.

#### Features and Benefits

##### Isothermal measuring junction

- Offers excellent thermal conductivity for the measuring junction

##### Molded insulator

- Isolates the isothermal measuring block from ambient airflow

##### Compact, universal package

- Fits into corners and other tight locations easily (0.44 inch (11.88 mm) side by 0.24 inch (6.10 mm) high)
- Molded insulator is removable for applications where an even smaller package is needed

##### Temperature rating of 200°C (400°F)

- Offers superior application flexibility for a wide variety of surfaces

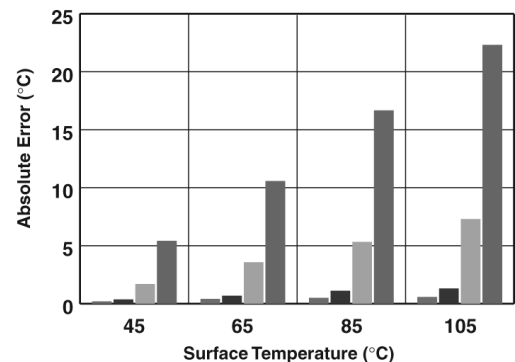

Legend:  
■ Watlow TST, no airflow  
■ Watlow TST, with airflow  
■ "Washer" Style TC, no airflow  
■ "Washer" Style TC, with airflow

# Thermocouples

## Surface Temperature Measurement

### TRUE SURFACE Thermocouple (TST)

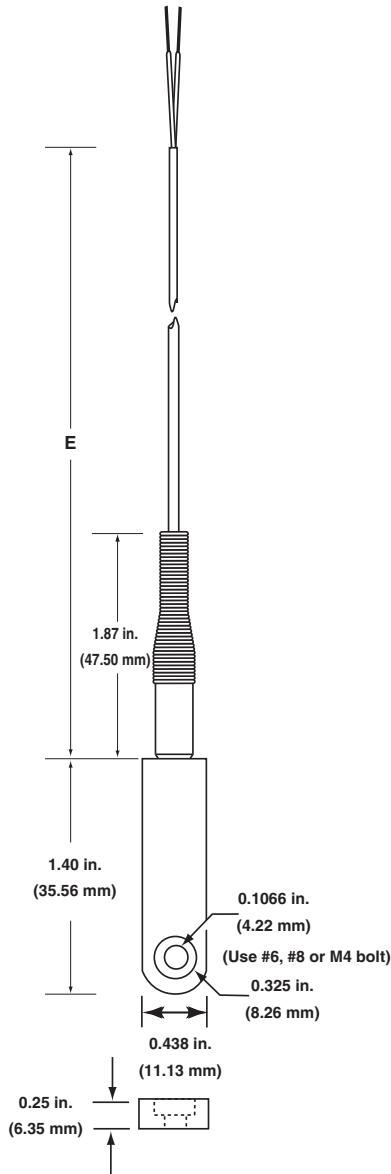

**Ordering Information**—To order, complete the part number on the right with the information below:

1 2 3 4 5 6 7 8 9  
T S T

**TRUE SURFACE Thermocouple**

**4. Lead Wire Construction**

- 2 = FEP 26 gauge solid
- 3 = FEP 26 gauge solid with shield and ground, not continuous to sheath (Terminations A, B and C are not available with this lead wire construction)

**5. Lead Wire Termination**

- A = Standard male plug
- B = Standard female jack
- C = Standard plug with mating connector
- F = Miniature male plug
- G = Miniature female jack
- H = Miniature plug with mating connector
- T = Standard, 1.5 inch (38.1 mm) split leads
- U = 1.5 inch (38.1 mm) split leads with spade lugs

**6. Junction**

	Ungrounded	Grounded
Single	U	G
Dual (Type K only)	W	H

**7. Calibration**

	Type J	Type K
Std. limits	J	K
Spc. limits	3	4

**8-9. Lead Length "E"**

01 to 99 feet

Thermocouples