

# IPAQ C530

## Universal HART-compatible 2-wire Transmitter



IPAQ C530 is a modern, HART® temperature transmitter developed to meet the highest standards of accuracy and reliability. A universal transmitter compatible with RTD, thermocouples, voltage and potentiometer sensors. It is fully compatible with HART® 7 and offers extended diagnostic information, for example device error, sensor and wiring conditions.

IPAQ C530 supports communication via NFC® (Near-field communication) and Bluetooth® which makes it possible to configure and monitor the transmitter remotely.

- High accuracy and long term stability
- Accepts RTD, T/C, mV and ohm
- Sensor error and system (sensor/transmitter) error correction
- 50-point Customized Linearization and Callendar-Van Dusen
- Rugged design tested for 10 g vibrations
- Configuration via USB, without external power
- Runtime counter - hour counter for elapsed operational time
- Communicates with HART Communicator or PC via modem
- Integrated in Emerson AMS and Siemens PDM systems

### Specifications:

<b>Input RTD</b>	2-, 3-, 4-wire connection
Pt100 ( $\alpha = 0.00385$ )	-200 to +850 °C / -328 to +1562 °F
PtX $10 \leq X \leq 1000$ ( $\alpha = 0.00385$ )	Upper range depending on X-value
Pt100 ( $\alpha = 0.003916$ )	-200 to +850 °C / -328 to +1562 °F
Ni100 <sup>1)</sup> , Ni120 <sup>2)</sup>	-60 to +250 °C / -76 to +482 °F
Ni1000 <sup>1)</sup>	-50 to +180 °C / -58 to +356 °F
Cu10 <sup>3)</sup>	-50 to +200 °C / -58 to +392 °F
<b>Input Resistance / potentiometer</b>	0 to 10000 / 100 to 10000
<b>Input Thermocouples</b>	Types B, C, D, E, J, K, N, R, S, T
<b>Input mV</b>	-10 to +1000 mV
<b>Sensor failure</b>	Upscale ( $\geq 21.0$ mA) or downscale ( $\leq 3.6$ mA) action
<b>Adjustments - Zero</b>	Any value within range limits
<b>Adjustments - Minimum spans</b>	
Pt100, Pt1000, Ni100, Ni1000	10 °C / 18 °F
Potentiometer	100
T/C, mV	2 mV
<b>Output</b>	4-20 / 20-4 mA, temperature linear
<b>Operating temperature</b>	-40 to +85 °C / -40 to +185 °F
<b>Galvanic isolation</b>	1500 VAC, 1 min
<b>Power supply</b>	IPAQ C530 8.5...36.0 VDC
	IPAQ C530X 8.5...30.0 VDC
<b>Intrinsic safety</b>	
IPAQ C530X ATEX:	II 1G Ex ia IIC T6...T4 Ga <sup>4)</sup>
IPAQ C530X IECEx:	Ex ia IIC T6...T4 Ga <sup>4)</sup>
IPAQ C330X cFMus:	IS CL I Div 1 GP A-D, T6...T4 CL I Zn 0 AEx/Ex ia IIC T6...T4 Ga <sup>4)</sup>
<b>Typical accuracy</b>	$\pm 0.08$ °C or $\pm 0.08$ % of span
<b>Connection head</b>	DIN B or larger

<sup>1)</sup> IEC 60751,  $\alpha = 0.00385$  and Pt100 acc. to JIS 1604,  $\alpha = 0.003916$  <sup>2)</sup> DIN 43760

<sup>3)</sup> Temperature, resistance or voltage linear, customized linearization possible <sup>4)</sup> For Tambient, see the manual

### Input connections

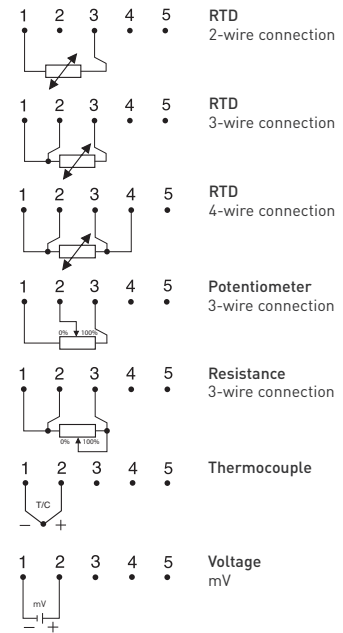

### Output connections

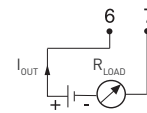

### Output load diagram

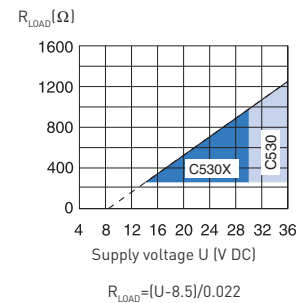

### Dimensions

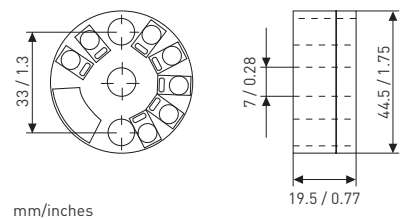

### Ordering information

IPAQ C530	70C5300010
IPAQ C530X (ATEX / IECEx)	70C530X010
IPAQ C530X (cFMus)	70C530F010
HART PC modem USB	70MEM00003
PC configuration kit (USB-conn.)	70CFGUSX01
ICON-BT Bluetooth kit	70CFGBT001
Configuration	70CAL00001