

IPAQ R530

Universal HART-compatible 2-wire Transmitter



IPAQ R530 is a modern, HART® temperature transmitter developed to meet the highest standards of accuracy and reliability. A universal transmitter compatible with RTD, thermocouples, voltage and potentiometer sensors. It is fully compatible with HART® 7 and offers extended diagnostic information, for example device error, sensor and wiring conditions. IPAQ R530 supports communication via NFC® (Near-field communication) and Bluetooth® which makes it possible to configure and monitor the transmitter remotely.

- High accuracy and long term stability
- Accepts RTD, T/C, mV and ohm
- Sensor error correction
- 50-point Customized Linearization and Callendar-Van Dusen
- Low temperature drift
- High security - Password protection and date of changes logged
- Configuration via USB, without external power
- Runtime counter - hour counter for elapsed operational time
- Communicates with HART Communicator or PC via modem
- Integrated in Emerson AMS and Siemens PDM systems

Specifications:

Input RTD	2-, 3-, 4-wire connection
Pt100 ($\alpha = 0.00385$)	-200 to +850 °C / -328 to +1562 °F
PtX 10 ($\alpha \leq X \leq 1000$) ($\alpha = 0.00385$)	Upper range depending on X-value
Pt100 ($\alpha = 0.003916$)	-200 to +850 °C / -328 to +1562 °F
Ni100 ¹⁾ , Ni120 ²⁾	-60 to +250 °C / -76 to +482 °F
Ni1000 ¹⁾	-50 to +180 °C / -58 to +356 °F
Cu10 ³⁾	-50 to +200 °C / -58 to +392 °F
Input Resistance / potentiometer	0 to 10000 / 100 to 10000
Input Thermocouples	Types B, C, D, E, J, K, N, R, S, T
Input mV	-10 to +1000 mV
Sensor failure	Upscale (≥ 21.0 mA) or downscale (≤ 3.6 mA) action
Adjustments - Zero	Any value within range limits
Adjustments - Minimum spans	
Pt100, Pt1000, Ni100, Ni1000	10 °C / 18 °F
Potentiometer	100
T/C, mV	2 mV
Output	4-20 / 20-4 mA, temperature linear
Operating temperature	-40 to +85 °C / -40 to +185 °F
Galvanic isolation	1500 VAC, 1 min
Power supply	IPAQ R530 8.5...36.0 VDC IPAQ R530X 8.5...30.0 VDC
Intrinsic safety	
IPAQ R530X ATEX:	II 1G Ex ia IIC T6...T4 Ga ⁴⁾
IPAQ R530X IECEx:	Ex ia IIC T6...T4 Ga ⁴⁾
IPAQ R530X cFMus:	IS CL I Div 1 GP A-D, T6...T4 CL I Zn 0 AEx/Ex ia IIC T6...T4 Ga ⁴⁾
Typical accuracy	$\pm 0.08\%$ or $\pm 0.08\%$ of span
Connection head	DIN B or larger

¹⁾IEC 60751, $\alpha = 0.00385$ and Pt100 acc. to JIS 1604, $\alpha = 0.003916$ ²⁾DIN 43760

³⁾Temperature, resistance or voltage linear, customized linearization possible ⁴⁾For Tambient, see the manual

Input connections

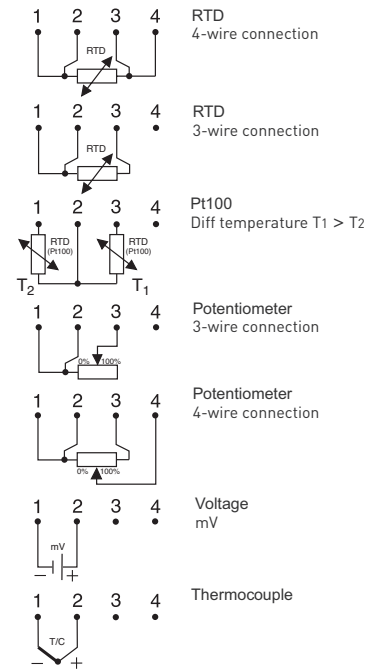

Output connections

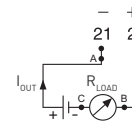

Output load diagram

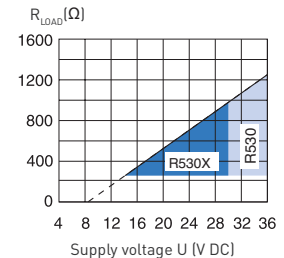

Dimensions

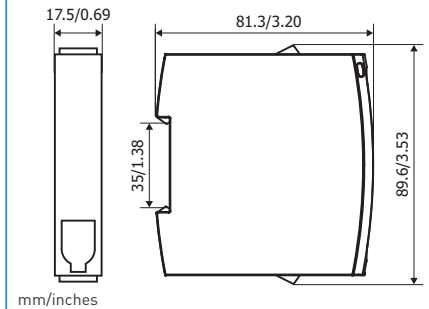

Ordering information

IPAQ R530	70R5300010
IPAQ R530X (ATEX / IECEx)	70R530X010
IPAQ R530X (cFMus)	70R530F010
HART PC modem USB	70MEM00003
PC configuration kit [USB-conn.]	70CFGUSX01
ICON-BT Bluetooth kit	70CFGBT001
Configuration	70CAL00001