User's Manual

ZEL-L62 / ZEL-L42 / ZEL-L22



Temperature Limit Controller



English



Revision History

Version	Description	Date
UM0L621A-0222	Initial release	February, 2022
UM0L621B-0922	Power Up sequence time	September, 2022

Warning Symbol

This document contains notices that you should observe to ensure your safety, as well as to protect the product and connected equipment. These notices are highlighted in the manual by a warning triangle and are marked as follows.

 The danger symbol indicates that death or severe personal injury may result if proper precautions are not taken. Do not proceed beyond a warning symbol until the indicated conditions are fully understood and met.

Preface

Original equipment manufacturer reserves the right to change information available in this document without notice. The manufacturer is not liable for any damages incurred to equipment / personal during installation or use of equipment as explained in this document. User must acquire sufficient knowledge & skills before using equipment in the application and follow all the local standards & regulations to meet safety requirements.

Copyright

The documentation and the software included with this product are copyrighted 2020 by Zesta Engineering Ltd. All rights are reserved. Zesta Engineering Ltd. reserves the right to make improvements in the products described in this manual at any time without notice.

No part of this manual may be reproduced/copied/translated or transmitted in any form or by any means without the prior written permission of Zesta Engineering Ltd. The information we supply is believed to be accurate and reliable as of this printing. However, we assume no responsibility for its use.

NOTE

It is strongly recommended that a process should incorporate a Limit Control like Zesta ZEL-L22 & -L62 which will shut down the equipment at a preset process condition to avoid possible damage to products or systems.

Contact Information

Head Office

Zesta Engineering Ltd.
212 Watline Avenue
Mississauga, ON L4Z 1P4
Tel: 905-568-3100
Website: www.zesta.com
Email: info@zesta.com

TABLE OF CONTENTS

1 INTRODUCTION	7
1.1 Introduction	7
1.2 Features	7
1.3 Limit Control Function.....	9
1.3.1 High Limit Control	9
1.3.2 Low Limit Control	9
1.3.3 High / Low Limit Control.....	9
1.3.4 Using Limit control Function.....	9
1.4 Specifications	10
1.5 Ordering Code	13
1.5.1 ZEL-L42 Ordering Code.....	13
1.5.2 ZEL-L62 Ordering Code.....	14
1.5.3 ZEL-L22 Ordering Code.....	15
1.5.4 Accessories.....	15
1.5.5 Related Products	15
1.6 Programming Port.....	16
1.7 Keys and Displays	17
1.8 Menu Flowchart.....	19
1.8.1 User Access Menu	20
1.8.2 Calibration Menu	20
1.8.3 Setup Menu.....	21
1.8.3.1 Basic Menu (bASE)	22
1.8.3.2 Output Menu (OUT).....	23
1.8.3.3 Communication Menu (CoMM).....	23
1.8.3.4 Alarm Menu (ALRM).....	24
1.8.3.5 Event Input Menu (EI).....	24
1.8.3.6 User Menu (SEL).....	25
1.9 Parameter Availability Table	25
1.10 Parameters Description.....	28
2 INSTALLATION AND WIRING	37
2.1 Unpacking.....	37
2.2 Mounting	37
2.2.1 ZEL-L42 Dimension	37
2.2.2 ZEL-L62 Dimension	40
2.2.3 ZEL-L22 Dimension	42
2.3 Wiring Precautions	43
2.3.1 ZEL-L42 Terminal Connection	44
2.3.2 ZEL-L62 Terminal Connection	45
2.3.3 ZEL-L22 Terminal Connection	46
2.4 Power Wiring	47
2.5 Sensor Installation	47
2.6 Sensor Input Wiring	47
2.7 Limit Control Output Wiring.....	48
2.7.1 Output 1	48
2.8 Alarm Wiring.....	49
2.8.1 Alarm 1(Output 2)	49
2.8.2 Alarm 2.....	50
2.8.3 Alarm 3.....	50

2.9 Event Input Wiring	50
2.10 Retransmission Wiring	50
2.11 RS-485 Data Communication	51
3 PROGRAMMING	52
3.1 User Security	52
3.2 Calibration Security	52
3.3 Signal Input.....	52
3.4 Limit Control Output.....	53
3.5 Set Point Range.....	53
3.6 Alarm	53
3.6.1 Alarm Types.....	54
3.6.2 Alarm Modes.....	55
3.6.2.1 Normal Alarm: ALMD = NoRM	55
3.6.2.2 Latching Alarm: ALMD = LtCH	55
3.6.2.3 Normal Alarm Reverse Output: ALMD =NoR.R.....	55
3.6.2.4 Latching Alarm Reverse Output: ALMD = LtC.R	55
3.6.3 Alarm Failure Transfer	56
3.7 User Select Menu Configuration.....	57
3.8 User Calibration or PV Shift	57
3.9 Digital Filter	58
3.10 Limit Annunciator	58
3.11 Remote Reset	58
3.12 Remote Lock.....	59
3.13 Power Up Logic	59
3.14 Reference Data	59
3.15 Failure Transfer	59
3.15.1 Output 1 Failure Transfer.....	60
3.15.2 Alarm Failure Transfer	60
3.16 Data Communication	60
3.16.1 RS-485 Setup	60
3.17 Retransmission	60
3.18 Event Input.....	60
3.18.1 Event Input Functions	61
4 APPLICATIONS.....	62
4.1 Limit Controller Application Wiring.....	62
4.2 High Temperature Protection with Remote Reset.....	63
5 CALIBRATION.....	64
5.1 Equipment Required Before Calibration	64
5.1.1 Manual Calibration Procedure	64
5.1.1.1 Calibrate Zero of A to D Converter	64
5.1.1.2 Calibrate Gain of A to D Converter	64
5.1.1.3 Calibrate Offset of Cold Junction Compensation.....	64
5.1.1.4 Calibrate Gain of Cold Junction Compensation.....	65
5.1.1.5 Calibrate RTD Input.....	65
5.1.1.6 Calibrate Linear Input	66
6 COMMUNICATION	67
6.1 Functions Supported	67
6.1.1 Function Code 03: Read Holding Registers.....	67

6.1.2 Function Code 06: Pre-set Single Register.....	68
6.1.3 Function Code 16: Pre-set Multiple Register.....	68
6.2 Exception Responses.....	69
6.3 Parameter Mapping.....	69
6.4 Error Code.....	69
6.5 Mode.....	69
6.6 PROG Code.....	70
6.7 Scaling.....	70
6.8 Communication Examples.....	70
6.8.1 Read PV.....	70
6.8.2 Perform Reset Function (same effect as pressing R key).....	70
6.8.3 Read All Parameters.....	71
6.8.4 Calibrate ADLO.....	71
6.8.5 Command Mode.....	71

TABLE OF TABLES

LIMIT CONTROLLER MODELS.....	7
PARAMETER AVAILABILITY TABLE.....	27
ENVIRONMENTAL SPECIFICATION.....	37
USER ACCESS RIGHTS.....	52
CALIBRATION ACCESS RIGHTS.....	52
FUNCTION CODE 03.....	67
FUNCTION CODE 06.....	68
FUNCTION CODE 16.....	69
EXCEPTION CODE.....	69
ERROR CODE.....	69
OPERATION MODE.....	70
PROGRAM CODE.....	70
DATA CONVERSION.....	70
COMMAND REGISTER.....	71

TABLE OF FIGURES

PROGRAMMING PORT.....	16
PROGRAMMING PORT CONNECTION WITH PROGRAMMING PORT ADAPTOR.....	16
ZEL-L42 FRONT PANEL KEYS AND DISPLAY.....	18
ZEL-L62 FRONT PANEL KEYS AND DISPLAY.....	18
ZEL-L22 FRONT PANEL KEYS AND DISPLAY.....	19
HOW CHARACTERS ARE DISPLAYED ON THE LCD SCREEN.....	19
USER ACCESS MENU.....	20
CALIBRATION MENU.....	21
BASIC MENU.....	22
OUTPUT MENU.....	23
COMMUNICATION MENU.....	23
ALARM MENU.....	24
EVENT INPUT MENU.....	24
USER MENU (SEL).....	25
ZEL-L42 DIMENSION WITH CLAMPS.....	38
ZEL-L42 DIMENSION WITHOUT CLAMP.....	39
ZEL-L62 DIMENSION WITH CLAMP.....	40
ZEL-L62 DIMENSION WITHOUT CLAMP.....	41
ZEL-L22 DIMENSION.....	42
LEAD TERMINAL.....	43
ZEL-L42 REAR TERMINAL CONNECTION – HIGH VOLTAGE INPUT POWER.....	44
ZEL-L42 REAR TERMINAL CONNECTION – LOW VOLTAGE INPUT POWER.....	44
ZEL-L62 REAR TERMINAL CONNECTION – HIGH VOLTAGE INPUT POWER.....	45
ZEL-L62 REAR TERMINAL CONNECTION – LOW VOLTAGE INPUT POWER.....	45
ZEL-L22 TERMINAL CONNECTION– HIGH VOLTAGE INPUT POWER.....	46

ZEL-L22 TERMINAL CONNECTION– LOW VOLTAGE INPUT POWER.....	46
POWER WIRING	47
ZEL-L42 SENSOR INPUT WIRING	48
ZEL-L62 SENSOR INPUT WIRING	48
ZEL-L22 SENSOR INPUT WIRING	48
OUTPUT 1 RELAY TO DRIVE LOAD	48
OUTPUT 1 RELAY TO DRIVE CONTACTOR	49
OUTPUT1 PULSED VOLTAGE TO DRIVE SSR.....	49
ALARM 1 OUTPUT TO DRIVE LOAD	49
ALARM 2 OUTPUT TO DRIVE LOAD	50
ALARM 3 OUTPUT TO DRIVE LOAD	50
EVENT INPUT WIRING	50
RETRANSMISSION WIRING - CURRENT	50
RETRANSMISSION WIRING - VOLTAGE	51
RS-485 WIRING.....	51
CONVERSION CURVE FOR LINEAR TYPE PROCESS SIGNAL	53
PROCESS VALUE HIGH (PV.HI)	54
PROCESS VALUE LOW (PV.LO).....	55
PROCESS VALUE HIGH- NORMAL ALARM.....	56
PROCESS VALUE HIGH- LATCHING ALARM	56
TWO POINT USER CALIBRATION	58
FILTER CHARACTERISTICS	58
LIMIT CONTROLLER APPLICATION WIRING	62
HIGH TEMPERATURE PROTECTION WITH REMOTE RESET	63
COLD JUNCTION CALIBRATION SETUP	65

1 Introduction

1.1 Introduction

The ZEL-L22, ZEL-L62 & ZEL-L42 are FM approved limit controllers that can be configured either as a high limit or as a low limit controller by the user. These limit controllers are powered by an 11-26 or 90-250 VDC / VAC supply, incorporating a 2 Amp relay output as a standard. The second output can be used as an alarm. Both outputs can be selected as a 5VDC or 14VDC logic output to drive an external device. The limit controllers can be incorporated with two event inputs, up to 3 alarm outputs, RS-485 communication, retransmission voltage or current output optionally. The limit controllers are fully programmable for **Linear current, Linear Voltage, PT100 and Thermocouple types J, K, T, E, B, R, S, N, L, U, P, C, and D**. The input signal is digitized by using an 18-bit A to D converter. Its fast-sampling rate allows the limit controller to protect fast processes.

Below are the different limit controller models of this series.

Model No	Mounting Type	DIN Size	Dimensions L x W x D(mm)	Depth Behind Panel (mm)
ZEL-L22	DIN RAIL		22.5x96x80	
ZEL-L62	Panel Mount	1/16DIN	48x48x59	50
ZEL-L42	Panel Mount	1/4DIN	96x96x59	50

1-1 *Limit Controller Models*

1.2 Features

This new generation of limit controllers has many unique features, as listed below.

- ❖ LCD Display
- ❖ High Accuracy 18 Bit A-D Conversion and 15 Bit D-A Conversion
- ❖ Fastest Sampling Rate of 200 msec
- ❖ Universal Input
- ❖ Up to 2 Event Inputs
- ❖ Remote Reset
- ❖ Remote Lock
- ❖ RS-485 communication
- ❖ Lockout Protection
- ❖ Bidirectional Menu Navigation
- ❖ On Field calibration
- ❖ °C / °F Temperature Ranges
- ❖ DIN Rail mount option
- ❖ Configurable display logic -SAFE

LCD Display

All limit controllers in this series are equipped with high brightness LCD Display.

Digital Communication

RS-485 Digital communication is available as an additional option. This option allows the units to be integrated with supervisory control systems and software. A Micro USB programming port is available for automatic configuration, calibration and testing without the need to access the keys on the front panel.

High Accuracy

This series of limit controllers are manufactured using an innovative technology which contains an 18-bit A to D converter for high-resolution measurement (true 0.1°F resolution for thermocouple and PT100 sensors).

Fast Sampling Rate

The sampling rate of the input A to D converter reaches 200 msec. This fast sampling rate allows the limit controller to protect fast processes.

Programming Port

A Micro USB programming port is available for automatic configuration, calibration and firmware upgrades without the need to access the keys on the front panel.

Lockout Protection

According to user security requirements, different security options can be enabled by using Code and Pass parameters.

Digital Filter

A first-order low-pass filter with a programmable time constant is used to improve the stability of the process value (PV). This is particularly useful in certain applications where the process value is too unstable to be read.

SEL Function

These limit controllers have the flexibility for the user to select those parameters which are most significant to them and put these parameters into the "USER" menu for quick access. There are up to 8 parameters that can be selected to allow the user to build their display sequence in the USER menu.

Event Input

Event Inputs are available as an option to change certain functions and the set point. Two Event Inputs are available in the ZEL-L42, ZEL-L62 and one event input is available in ZEL-L22.

Remote Reset

The remote reset can be applied via event input. This will do the same action as reset  key.



Remote Lock

The remote lock can be enabled via event input. This will protect the parameters from unauthorized access.

Analog Retransmission

Analog retransmission is available as an option. The limit controller has a 15-bit D to A converter for a linear current or voltage retransmission output.

Bidirectional Menu Navigation

The limit controller has bidirectional menu navigation. This will allow the user to access previous menu settings easily by using   keys.

1.3 Limit Control Function

When a temperature controller is controlling the temperature of a furnace or other heating device, a malfunction in the temperature controller may cause the furnace temperature to rise, resulting in damage to the heated product or the furnace itself. When this situation occurs with the Limit controller, if the temperature rises above the pre-set limit temperature (Heating Application), the limit output will open and the heater system circuit can be shut down to stop the heat source. In addition, the limit output will remain open even when the temperature returns to the normal range. A safer system can be constructed because the limit output will remain open until it is reset manually or via reset via remote reset.

With these Limit Controllers, it is possible to establish a lower limit instead of an upper limit so that the limit function operates when the temperature falls below the limit setting value (Cooling Application). When an input error occurs, the limit output will open and will remain in this condition until the sensor error is fixed and a reset is provided.

1.3.1 High Limit Control

If Hi. is selected for OUT1, the unit will perform high limit control. When power is applied the OUT1 relay is de-energized. After 6.5 seconds self-test period, if the process is below the high limit set point (HSP1), the output 1 relay will be energized and OUT1 indicator will go off. If the process goes above the high limit set point, the relay will be de-energized, the OUT1 indicator will go on and the display will show the process value. After the process falls below the high limit set point and the reset R key is pressed or the remote reset input is applied, the relay will be energized and the OUT1 indicator will go off.

1.3.2 Low Limit Control

If Lo. is selected for OUT1, the unit will perform low limit control. When power is applied the OUT1 relay is de-energized. After 6.5 seconds self-test period, if the process is above the low limit set point (LSP1), the output 1 relay will be energized and OUT1 indicator will go off. If the process goes below the low limit set point, the relay will be de-energized, the OUT1 indicator will go on and the display will show the process value. After the process rises above the low limit set point and the reset R key is pressed or the remote reset input is applied, the relay will be energized and the OUT1 indicator will go off.

1.3.3 High / Low Limit Control

If Hi. Lo is selected for OUT1, the unit will perform high/low limit control. When power is applied the OUT1 relay is de-energized. After 6.5 seconds self-test period, if the process is below the high limit set point (HSP1) and above the low limit set point (LSP1), the output 1 relay will be energized and OUT1 indicator will go off. If the process goes above the high limit set point or below the low limit set point, the relay will be de-energized, the OUT1 indicator will go on and the display will show the process value. After the process is within the normal operation range, and the reset R key is pressed or the remote reset input is applied, the relay will be energized and the OUT1 indicator will go off.

1.3.4 Using Limit control Function

When the measured temperature (PV) exceeds the limit setting value, the limit output relay opens and the OUT1 operation indicator turns ON. If the limit output relay opens (limit alarm is ON), the limit output relay will remain open until the operator checks operation (performs resetting operation).

1.4 Specifications

Specification	ZEL-L22	ZEL-L62	ZEL-L42	
Power Supply	90 to 250VAC, 47 to 63Hz, 20 to 28 VAC, 47-63Hz / 11 to 40 VDC			
Power Consumption	8VA, 4W Maximum	10VA, 5W Maximum.,	12VA, 6W Maximum	
Over Voltage Category	II			
Signal Input				
Type	Thermocouple (J, K, T, E, B, R, S, N, L, U, P, C, D), RTD (PT100(DIN), PT100(JIS)), Current (mA), Voltage (V, mV)			
Resolution	18 Bits			
Sampling Rate	5 Times / Second (200msec)			
Maximum Rating	-2VDC minimum, 12VDC maximum			
Input Characteristics	Type	Range	Accuracy @ 25°C	Input Impedance
	J	-120°C to 1000°C (-184°F to 1832°F)	±2°C	2.2 MΩ
	K	-200°C to 1370°C (-328°F to 2498°F)	±2°C	2.2 MΩ
	T	-250°C to 400°C (-418°F to 752°F)	±2°C	2.2 MΩ
	E	-100°C to 900°C (-148°F to 1652°F)	±2°C	2.2 MΩ
	B	0°C to 1820°C (32°F to 3308°F)	±2°C (200°C to 1800°C)	2.2 MΩ
	R	0°C to 1767.8°C (32°F to 3214°F)	±2°C	2.2 MΩ
	S	0°C to 1767.8°C (32°F to 3214°F)	±2°C	2.2 MΩ
	N	-250°C to 1300°C (-418°F to 2372°F)	±2°C	2.2 MΩ
	L	-200°C to 900°C (-328°F to 1652°F)	±2°C	2.2 MΩ
	U	-200°C to 600°C (-328°F to 1112°F)	±2°C	2.2 MΩ
	P	0°C to 1395°C (32°F to 2543°F)	±2°C	2.2 MΩ
	C	0°C to 2300°C (32°F to 4172°F)	±2°C	2.2 MΩ
	D	0°C to 2300°C (32°F to 4172°F)	±2°C	2.2 MΩ
	PT100(DIN)	-210°C to 700°C (-346°F to 1292°F)	±0.4°C	1.3KΩ
	PT100(JIS)	-200°C to 600°C (-328°F to 1112°F)	±0.4°C	1.3KΩ
	mA	-3mA to 27mA	±0.05%	2.5Ω
VDC	-1.3VDC to 11.5VDC	±0.05%	1.5MΩ	
mV	0 to 50mV	±0.05%	2.2 MΩ	
Temperature Effect	1.5μV /°C for all inputs except mA input, 3.0μV /°C for mA			
Sensor Lead Resistance Effect	Thermocouple: 0.2μV /°Ω; 3-wire RTD: 2.6°C /Ω of Difference of Resistance of two leads 2-wire RTD: 2.6°C /Ω of Sum of Resistance of two leads			
Burn-out Current	200nA			
CMRR	120dB			
NMRR	55dB			
Sensor Break Detection	Sensor open for Thermocouple, RTD and mV inputs, Sensor short for RTD input, Below 1mA for 4-20mA input, Below 0.25VDC for 1 - 5VDC input, Not available for other inputs.			
Sensor Break Response Time	Within 4 seconds for Thermocouple, RTD and mV inputs, 0.1 second for 4-20mA and 1 - 5VDC inputs.			
Digital Filter				
Function	First Order			
Time Constant	0,0.2, 0.5, 1, 2, 5, 10, 20, 30, 60 Seconds, Programmable			
Event Input				
Number of Event Inputs	1	2	2	
Logic Low	-10VDC minimum, 0.8VDC maximum.			
Logic High	2VDC minimum, 10VDC maximum			

Specification	ZEL-L22	ZEL-L62	ZEL-L42
Functions	Remote Lock, Remote Reset Output1, HSP2, LSP2, HLS2, HSP3, LSP3, HLS3, Reset Alarm1, Reset Alarm2, Reset Alarm 3, Reset All Alarms, Cancel Latch, Reset Reference data		
Output 1 /Output 2			
Limit Control Function	High Limit, Low Limit and High / Low Limit		
Type	Relay, Pulsed Voltage		
Relay Type	Form A		
Relay Rating	2A,240V AC,200000 Life Cycles for Resistive Load		
Pulsed Voltage	Source Voltage 5VDC, Current Limiting Resistance 66Ω		
Temperature Effect	±0.01% of Span/ °C		
Alarm			
Relay Type	Form A		
Maximum Rating	2A,240VAC,200000 Life Cycles for Resistive Load		
Alarm Functions	Process High, Process Low		
Alarm Mode	Normal, Latching, Normal Reverse, Latching Reverse		
Data Communication			
Interface	RS-485		
Protocol	Modbus RTU (Slave Mode)		
Address	1 to 247		
Baud Rate	2.8KBPS to 115.2KBPS		
Parity Bit	None, Even or Odd		
Stop Bit	1 or 2 Bits		
Data Length	7 or 8 Bits		
Communication Buffer	160 Bytes		
Analog Retransmission			
Output Signal	4-20mA, 0-20 mA,0 - 10VDC		
Resolution	15 Bits		
Accuracy	±0.05% of Span ± 0.0025% / °C		
Load Resistance	0 to 500Ω for current output, 10KΩ minimum for Voltage Output		
Output Regulation	0.01% for full load change		
Output Setting Time	0.1Second (stable to 99.9%)		
Isolation Breakdown	1000VAC min		
Integral Linearity Error	±0.005% of span		
Temperature Effect	±0.0025% of span /°C		
Saturation Low	0mA or 0VDC		
Saturation High	22.2mA or 5.55V,11.1V min		
Linear Output Ranges	0 - 22.2mA (0 - 20mA/4 - 20mA), 0 - 5.55VDC (0 - 5VDC, 1 - 5VDC),0 - 11.1VDC (0 - 10VDC)		
User Interface			
Keypad	4 Keys		
Display Type	4 Digit LCD Display		
No of Display	2		
Upper Display Size	0.31" (8mm)	0.58" (15mm)	0.98" (25mm)

Specification	ZEL-L22	ZEL-L62	ZEL-L42
Lower Display Size	0.25" (6.5mm)	0.3" (7.8mm)	0.55" (14mm)
Programming Port			
Interface	Micro USB		
PC Communication Function	Firmware upgrade		
Environmental and Physical Specifications			
Operating Temperature	-10°C to 50°C		
Storage Temperature	-40°C to 60°C		
Humidity	0 to 90 % RH (Non-Condensing)		
Altitude	2000 Meters Maximum		
Pollution	Degree II		
Insulation Resistance	20MΩ Minimum (@500V DC)		
Dielectric Strength	2000VAC, 50/60 Hz for 1 Minute		
Vibration Resistance	10 to 55 Hz, 10m/s ² for 2 Hours		
Shock Resistance	200 m/s ² (20g)		
Housing	Flame Retardant Polycarbonate		
Mounting	DIN-Rail	Panel	Panel
DIN Size		1/16	1/4
Dimensions (W*H*D) (mm)	22.5*96*83	48*48*59	96*96*59
Depth Behind Panel (mm)		50	50
Cut Out Dimensions (mm)		45*45	92*92
Weight (grams)	160	160	290
Approval Standards			
Safety	FM Class 3545, UL61010-1, CSA 22.2 No.61010-1-12, EN61010-1 (IEC1010-1), ROHS, REACH		
Protective Class	IP50 for the front panel, IP20 for rear terminals and housing. All indoor use.		
EMC	EN61326		

1.5 Ordering Code

1.5.1 ZEL-L42 Ordering Code

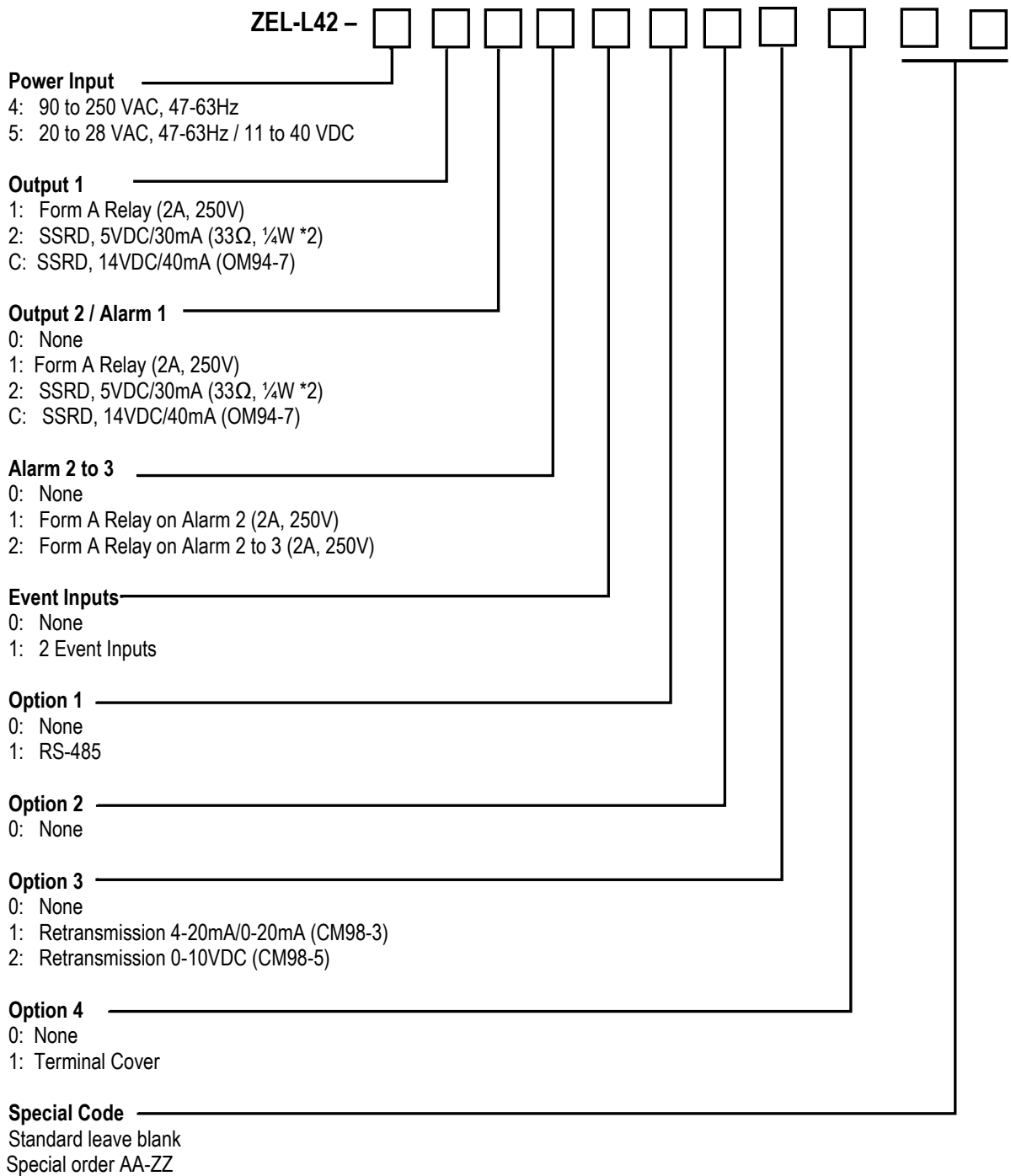

1.5.2 L62 Ordering Code

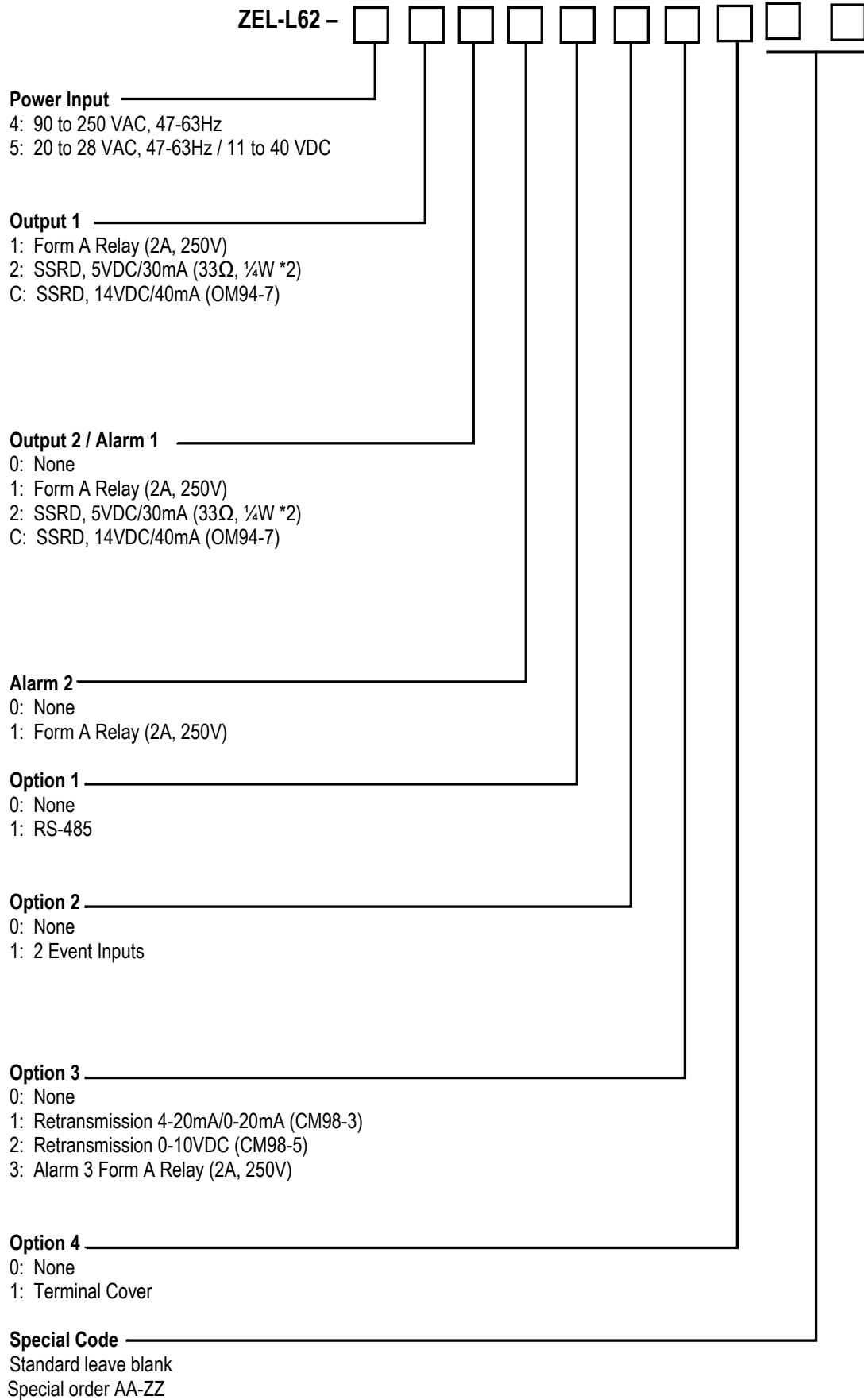

1.5.3 L22 Ordering Code

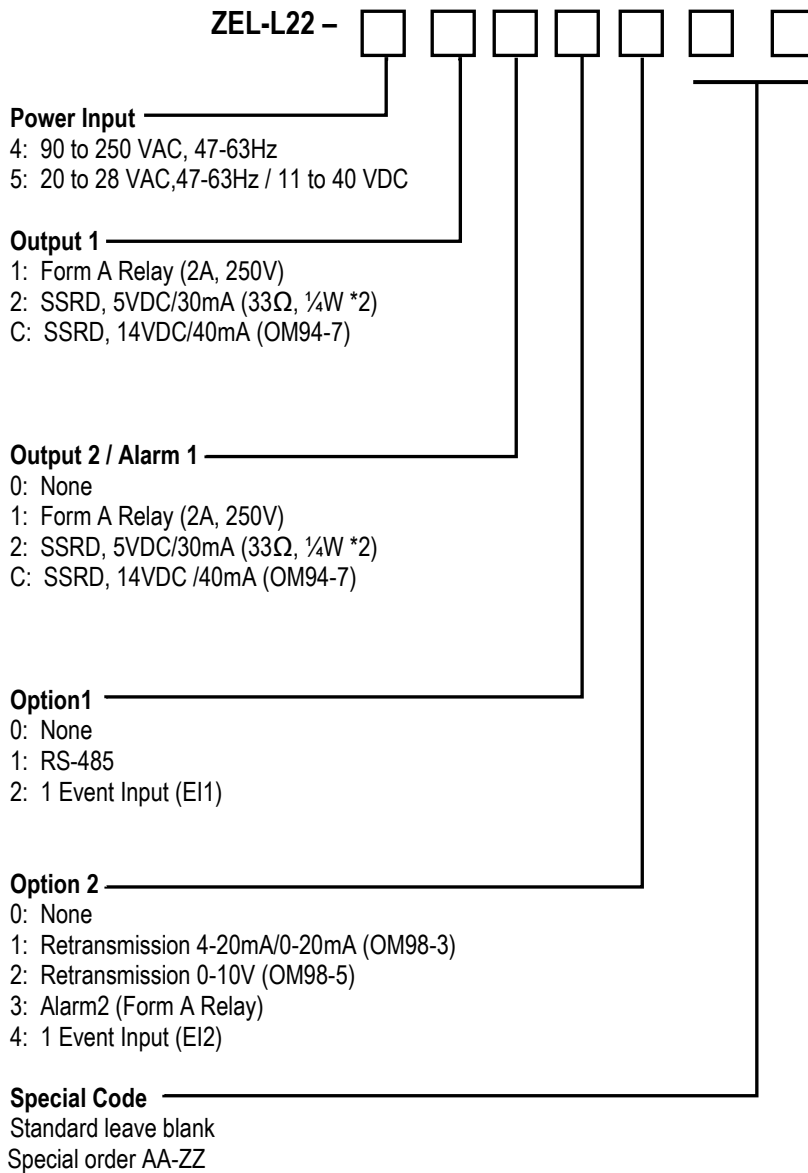

1.5.4 Accessories

- OM94-7 = 14VDC/40mA SSR Drive Module
- OM98-3 = Isolated 4-20mA/0-20mA Retransmission Module for ZEL-L22
- OM98-5 = Isolated 0-10VDC Retransmission Module for ZEL-L22
- CM98-3 = Isolated 4-20mA/0-20mA Retransmission Module for ZEL-L62 & ZEL-L42
- CM98-5 = Isolated 0-10VDC Retransmission Module for ZEL-L62 & ZEL-L42
- PA98-1 = USB Programming Adaptor
- CC98-1 = Programming Port Cable (1.5m)

1.5.5 Related Products

- SNA10A = Smart Network Adaptor for third party software, which converts up to 255 channels of RS-485 or RS-422 to be usable on an RS-232 network.
- ZEL-Set = Configuration Software

1.6 Programming Port

A Micro USB Port provided on the limit controller can be used to connect to a PC by using a programming port cable (CC98-1) and a programming adapter (PA98-1) for firmware upgrades. The limit controller can also be connected to an ATE system for automatic calibration and testing using the micro-USB port. The programming port is used for off-line automatic setup and testing procedures only. Do not attempt to make any connections to this port while the limit controller is being used during normal operation.

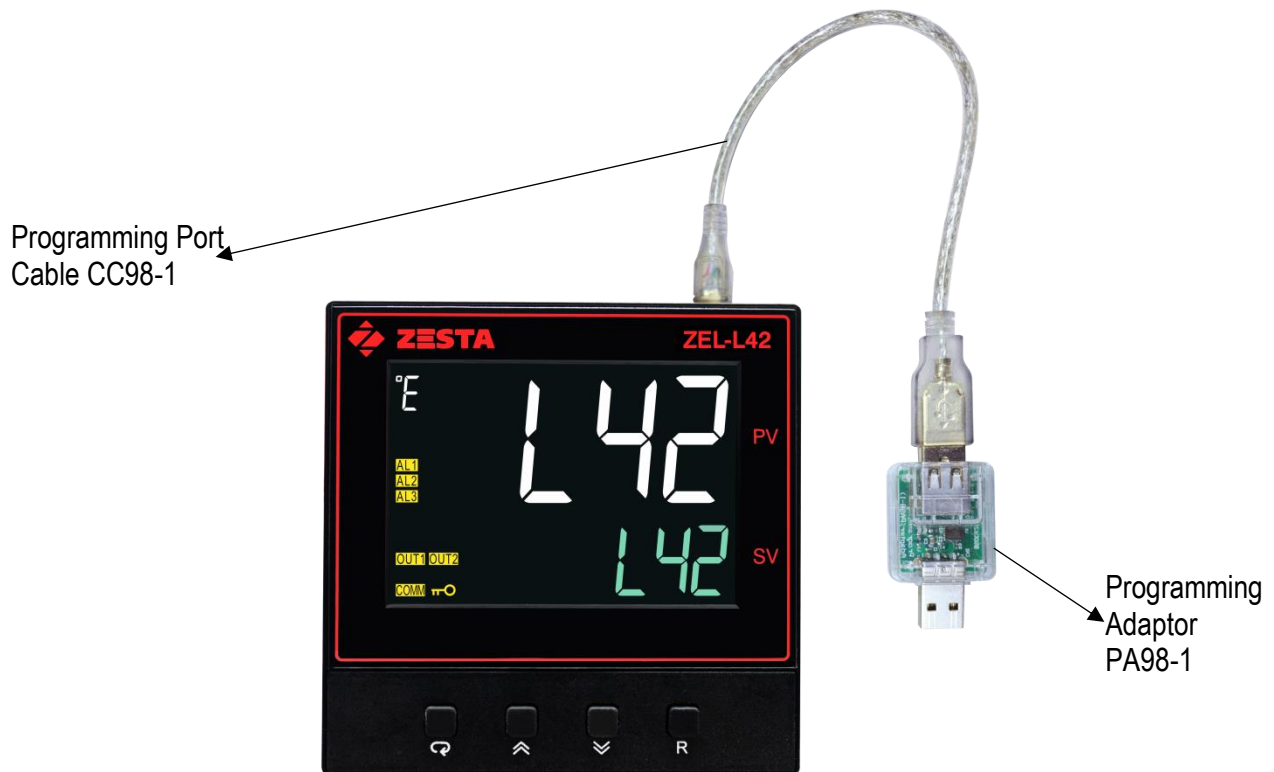
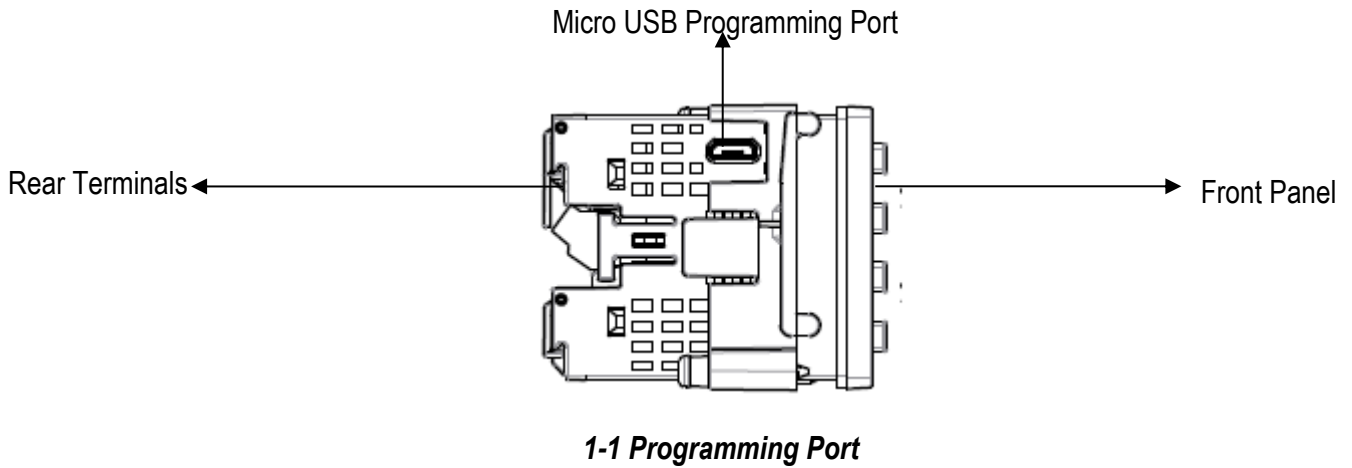

1-2 Programming Port Connection with Programming Port Adaptor

1.7 Keys and Displays

KEYPAD OPERATION

SCROLL KEY:

This key is used to select a parameter to be viewed or adjusted and navigate to the next parameter.

ENTER KEY:

Press  and hold for 5 seconds or longer to:

1. Enter the setup menu. The display will show. 

Press and hold  for 8.6 seconds, then let go to select calibration mode.

2. Perform calibration of a selected parameter during the calibration procedure. The display will show 

UP KEY:

This key is used to increase the value of the selected parameter.

DOWN KEY:

This key is used to decrease the value of the selected parameter.

RESET KEY:

This key is used to:

1. Revert the display to the home screen.
2. Reset a latching alarm once the alarm condition is removed.
3. Reset the limit condition after the process is within the limit.
4. Reset the limit annunciator.

Note: If the RESET key is left pressed, only ONE reset operation will occur. If the unit subsequently goes into a state where reset is required again, the RESET  key (or remote reset contacts) must be released (opened) and pressed (closed) again.

POWER UP SEQUENCE:

During power up the following sequence will be followed.

1. All segments of display and indicators are left off for 4 second.
2. All segments of display and indicators are lit for 1.5 seconds.
3. The upper display will show PROG and the lower display will show the Firmware version for 1.5 seconds.

NORMAL DISPLAY:

During normal operation, the unit will display the process value, and the word SAFE.

ABNORMAL DISPLAY:

Whenever the process is outside the normal range, the lower display will display the limit set point value instead of displaying the word SAFE.

SENSOR BREAK DISPLAY:

If a sensor break is detected in the sensor circuit, the display will show: SBER

A-D FAILURE DISPLAY:

If failure is detected in the A-D converter circuit, the display will show ADER

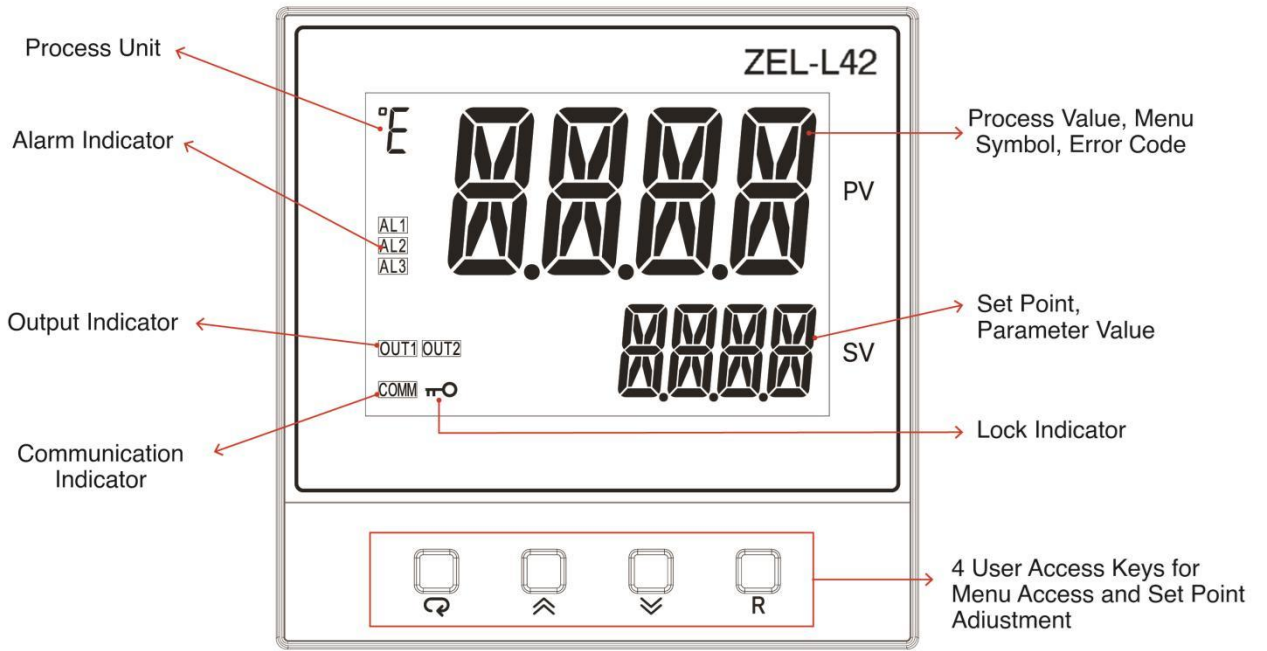

1-3 ZEL-L42 Front Panel Keys and Display

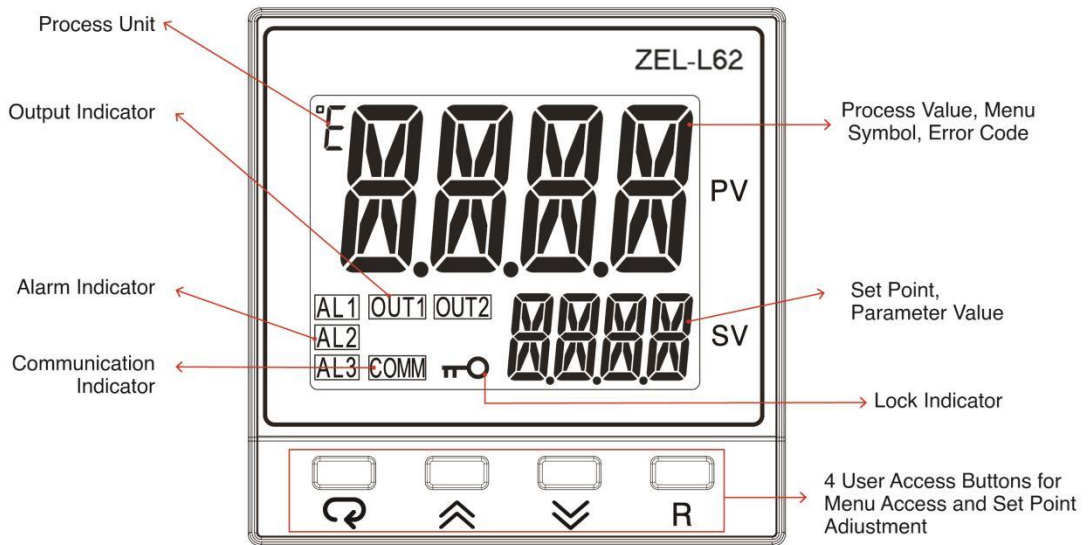

1-4 ZEL-L62 Front Panel Keys and Display

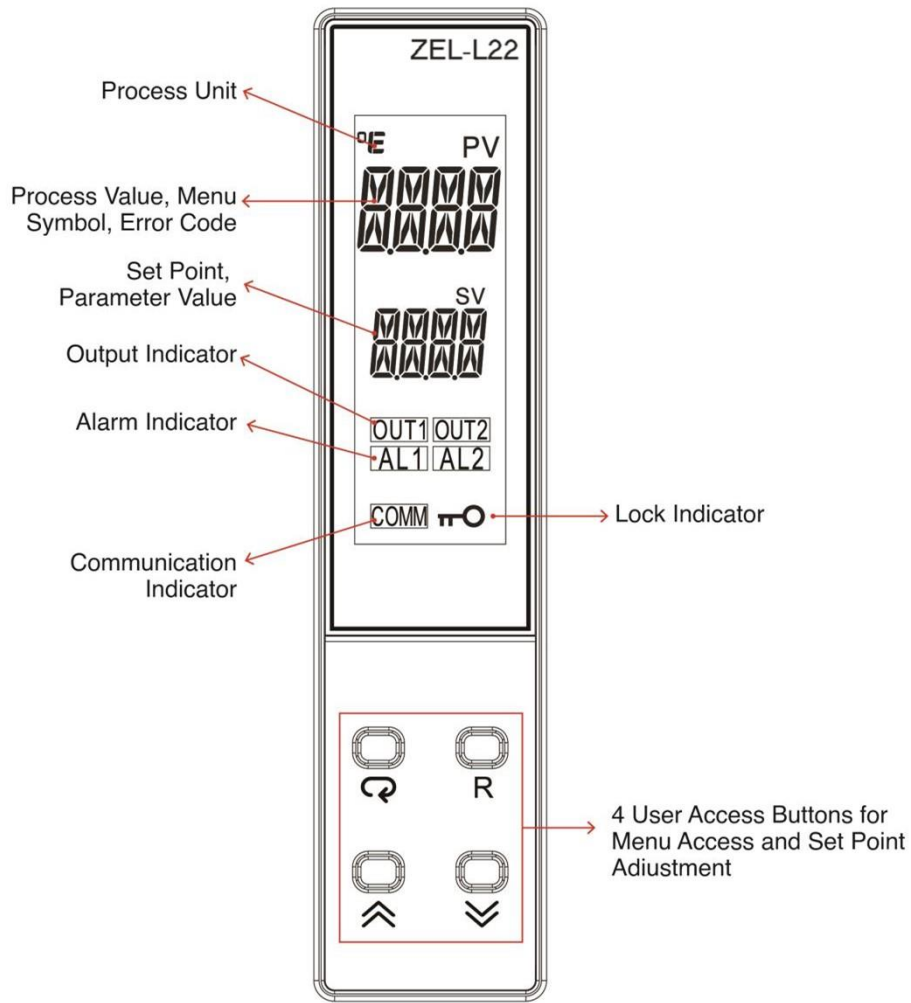

1-5 ZEL-L22 Front Panel Keys and Display

A	À	B	À	C	Ç	D	Ð	E	É	F	Ë	G	Û
H	Ë	I	Ì	J	Ï	K	Ë	L	Ë	M	Ë	N	Ë
O	Ó	P	Ï	Q	Û	R	Ë	S	Ë	T	Ë	U	Û
V	Ï	W	Ë	X	Ë	Y	Ë	Z	Ë				

1-6 How Characters are Displayed on the LCD screen

1.8 Menu Flowchart

The Menu has been divided into 3 groups. They are as follows:

1. User Menu
2. Setup Menu
3. Calibration Mode Menu

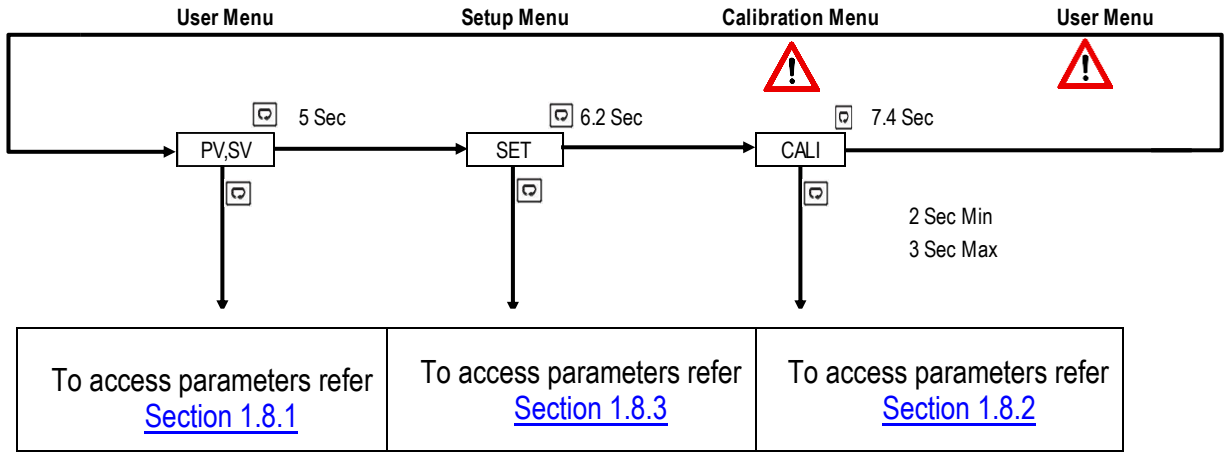

Press for the next parameter
 Press and key to return to the previous parameter.

1.8.1 User Access Menu

The below user menu parameters are available for easy user access depends on the selection in the user menu configuration. The upper display will show the parameters and the lower display will show its selection.

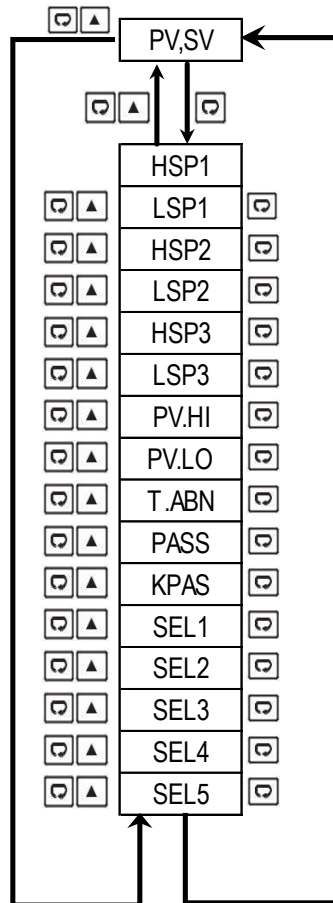

1-7 User Access Menu

1.8.2 Calibration Menu

Press key for 2 seconds or longer (not more than 3 seconds) then release it to enter calibration Mode. KPAS = KCOD for entering to calibration mode.
 Press Key for 5 seconds to perform calibration.

Note:

- ❖ Calibration modes will break the limit loop and change some of the previous setting data. Make sure that the system is allowable to apply these modes.
- ❖ The flow chart shows a complete list of all parameters. For actual application, the number of available parameters will vary depending on the setup and model of the limit controller and will be less than that shown in the flow chart.

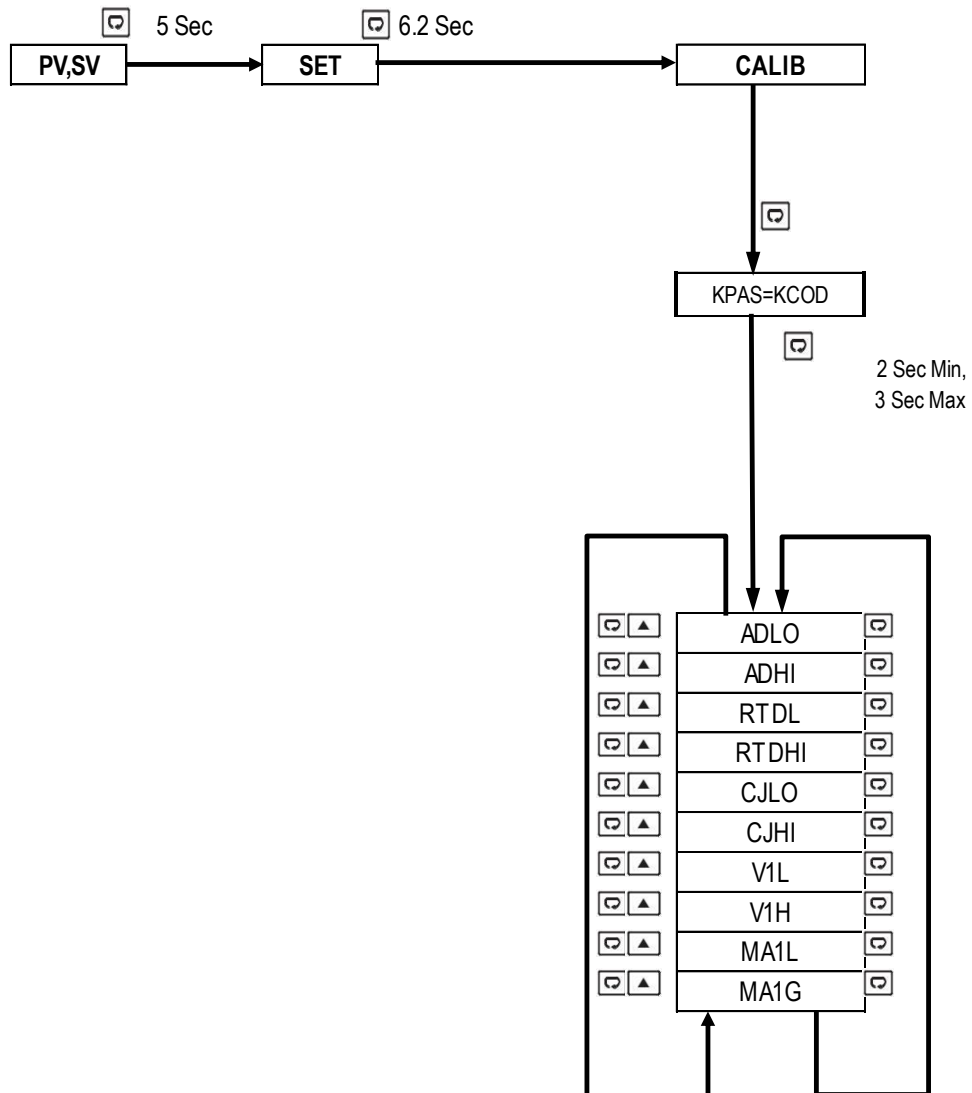

1-8 Calibration Menu

1.8.3 Setup Menu

The setup menu has been categorized into six categories for easy user access. They are listed as below.

1. [Basic Menu](#)
2. [Output Menu](#)
3. [Alarm Menu](#)
4. [Event Input Menu](#)
5. [User Menu](#)
6. [Communication Menu](#)

1.8.3.1 Basic Menu (bASE)

Once SET is displayed in the upper display, use \uparrow or \downarrow key until bASE is displayed in the lower display. Then use \square key to access to basic menu parameters. The upper display will show the parameters and the lower display will show its selection.

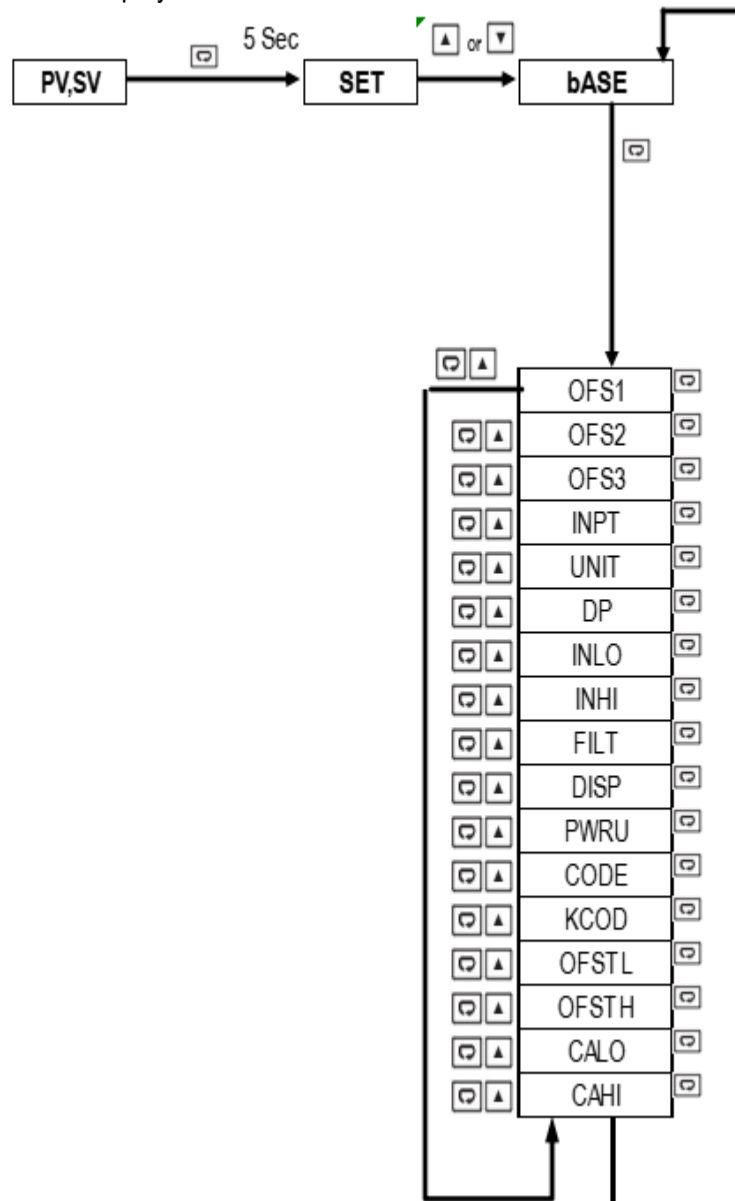

1-9 Basic Menu

1.8.3.2 Output Menu (OUT)

Once SET is displayed in the upper display, use ▲ or ▼ key until OUT is displayed in the lower display. Then use ◀ key to access to output parameters. The upper display will show the parameters and the lower display will show its selection.

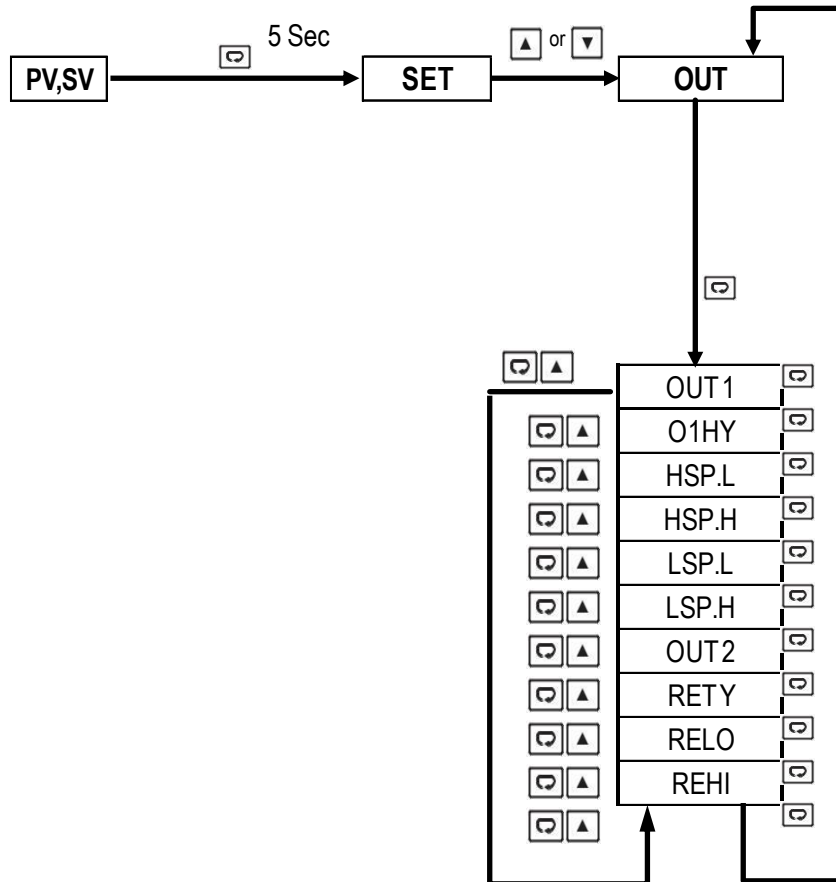

1-10 Output Menu

1.8.3.3 Communication Menu (CoMM)

Once SET is displayed in the upper display, use ▲ or ▼ key until CoMM is displayed in the lower display. Then use ◀ key to access to communication parameters. The upper display will show the parameters and the lower display will show its selection.

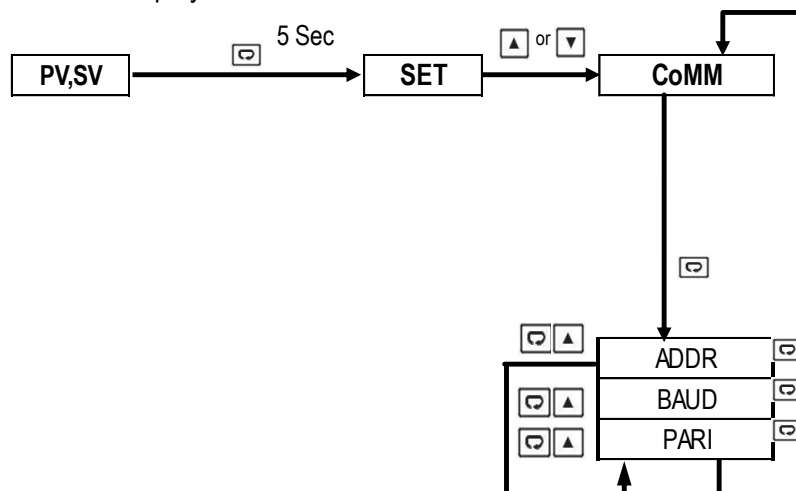

1-11 Communication Menu

1.8.3.4 Alarm Menu (ALRM)

Once SET is displayed in the upper display, use \uparrow or \downarrow key until ALRM is displayed in the lower display. Then use \square key to access to alarm parameters. The upper display will show the parameters and the lower display will show its selection.

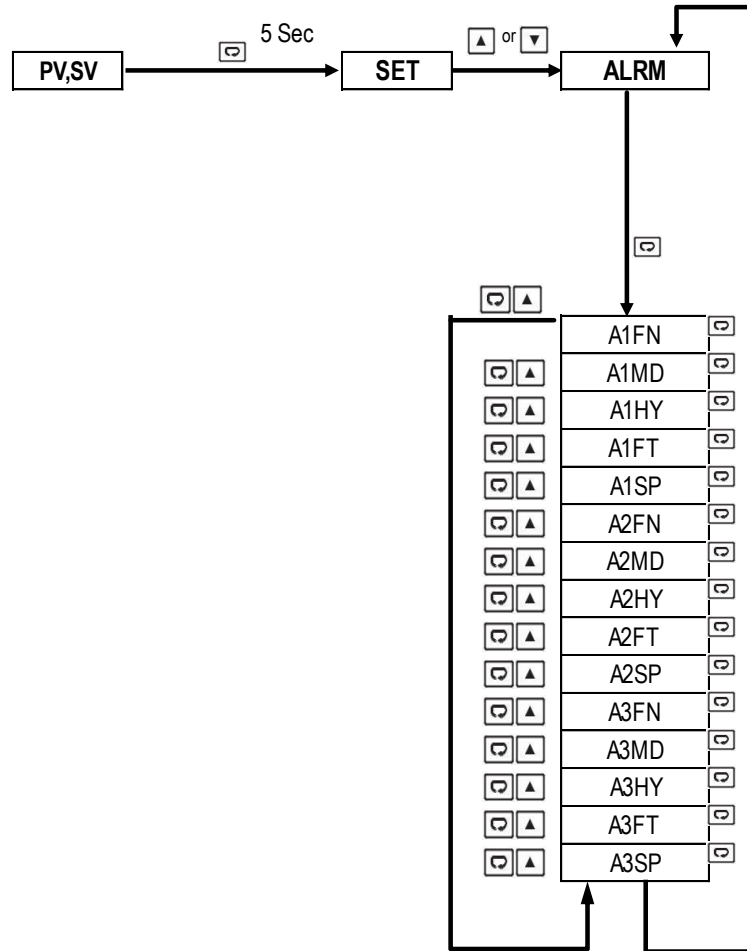

1-12 Alarm Menu

1.8.3.5 Event Input Menu (EI)

Once SET is displayed in the upper display, use \uparrow or \downarrow key until EI is displayed in the lower display. Then use \square key to access to event input parameters. The upper display will show the parameters and the lower display will show its selection.

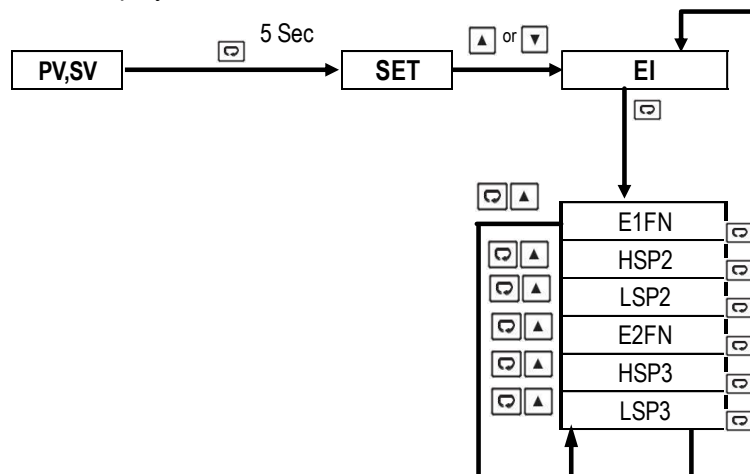

1-13 Event Input Menu

1.8.3.6 User Menu (SEL)

Once SET is displayed in the upper display, use ▲ or ▼ key until SEL is displayed in the lower display. Then use □ key to access to user menu parameters. The upper display will show the parameters and the lower display will show its selection.

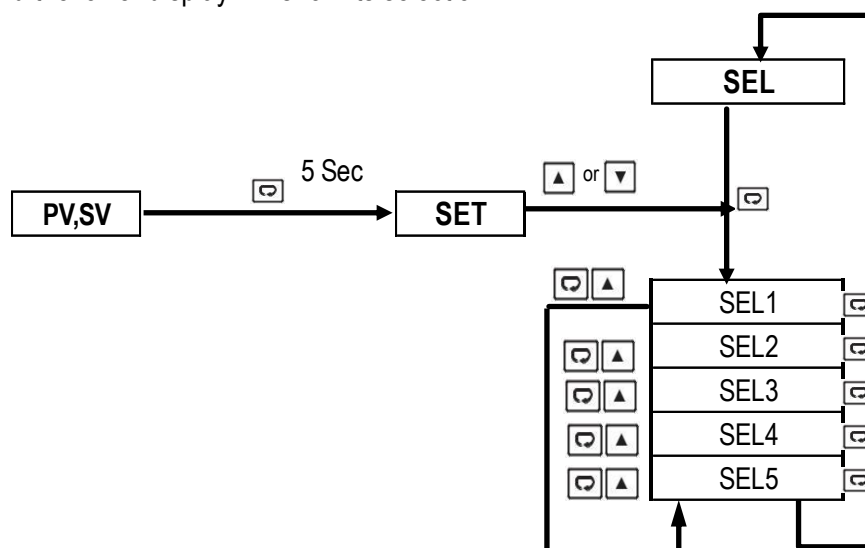

1-14 User Menu (SEL)

1.9 Parameter Availability Table

Register Address	Parameter Notation	L22	L62	L42	Existence Conditions
0	HSP1	✓	✓	✓	Exists if OUT1 selects HI or HL
1	LSP1	✓	✓	✓	Exists if OUT1 selects Lo or HL
2	HSP2	✓	✓	✓	Exists if E1FN exists and E1FN selects HSP2 or HLS2 or if E2FN exists and E2FN selects HSP2 or HLS2
3	LSP2	✓	✓	✓	Exists if E1FN exists and E1FN selects LSP2 or HLS2 or if E2FN exists and E2FN selects LSP2 or HLS2
4	HSP3	✓	✓	✓	Exists if E1FN exists and E1FN selects HSP3 or HLS3 or if E2FN exists and E2FN selects HSP3 or HLS3
5	LSP3	✓	✓	✓	Exists if E1FN exists and E1FN selects LSP3 or HLS3 or if E2FN exists and E2FN selects LSP3 or HLS3
6	INPT	✓	✓	✓	Exists unconditionally
7	UNIT	✓	✓	✓	Exists unconditionally
8	DP	✓	✓	✓	Exists unconditionally
9	INLO	✓	✓	✓	Exists if INPT selects 4-20mA or 0-20mA or 0-5V or 1-5V or 0-10V or 0-50mV
10	INHI	✓	✓	✓	
11	HSPH	✓	✓	✓	Exists if OUT1 selects HI or HL
12	HSPH	✓	✓	✓	Exists if OUT1 selects HI or HL
13	LSPL	✓	✓	✓	Exists if OUT1 selects Lo or HL
14	LSPH	✓	✓	✓	Exists if OUT1 selects Lo or HL
15	FILT	✓	✓	✓	Exists unconditionally
16	DISP	✓	✓	✓	Exists unconditionally
17	OUT1	✓	✓	✓	Exists unconditionally
18	O1HY	✓	✓	✓	Exists unconditionally
19	OUT2	✓	✓	✓	Exists unconditionally
20	A1FN	✓	✓	✓	Exists if OUT2 selects AL1

Register Address	Parameter Notation	L22	L62	L42	Existence Conditions
21	A1MD	✓	✓	✓	Exists if OUT2 selects AL1 and A1FN selects PVHI or PVLO
22	A1HY	✓	✓	✓	Exists if OUT2 selects AL1 and A1FN selects PVHI or PVLO
23	A1FT	✓	✓	✓	Exists if OUT2 selects AL1 and A1FN selects PVHI or PVLO
24	A1SP	✓	✓	✓	Exists if OUT2 selects AL1 and A1FN selects PVHI or PVLO
25	A2FN	✓	✓	✓	L62/L42: Exists unconditionally L22: Exists if OFS2 selects AL2
26	A2MD	✓	✓	✓	L62/L42: Exists if A2FN selects PVHI or PVLO, L22: Exists if OFS2 selects AL2 and A2FN selects PVHI or PVLO
27	A2HY	✓	✓	✓	
28	A2FT	✓	✓	✓	
29	A2SP	✓	✓	✓	
30	A3FN		✓	✓	L42: Exists unconditionally L62: Exists if OFS3 is set to ALM3 L22: Not available
31	A3MD		✓	✓	L42: Exists if A3FN selects PVHI or PVLO, L62: Exists if OFS3 is set to ALM3 and A3FN is set to PVHI or PVLO L22: Not available
32	A3HY		✓	✓	
33	A3FT		✓	✓	
34	A3SP		✓	✓	
35	OFS1	✓	✓	✓	Exists unconditionally
36	OFS2	✓	✓	✓	Exists unconditionally
37	OFS3		✓	✓	L62/L42: Exists unconditionally L22: Not available
38	E1FN	✓	✓	✓	L42: Exists unconditionally L62: Exists if OFS2 selects E112 L22: Exists if OFS1 selects E11
39	E2FN	✓	✓	✓	L42: Exists unconditionally L62: Exists if OFS2 selects E112 L22: Exists if OFS2 selects E12
40	RETY	✓	✓	✓	L62/L42: Exists if OFS3 selects 4-20 or 0-20 or 0-5V or 1-5V or 0-10 L22: Exists if OFS2 selects 4-20 or 0-20 or 0-5V or 1-5V or 0-10
41	RELO	✓	✓	✓	
42	REHI	✓	✓	✓	
43	ADDR	✓	✓	✓	
44	BAUD	✓	✓	✓	Exists if OFS1 selects RS-485
45	PARI	✓	✓	✓	Exists if OFS1 selects RS-485
46	OFTL	✓	✓	✓	Exists unconditionally
47	OFTH	✓	✓	✓	Exists unconditionally
48	CALO	✓	✓	✓	Exists unconditionally
49	CAHI	✓	✓	✓	Exists unconditionally
50					
51	ADLO	✓	✓	✓	Exists unconditionally
52	ADHI	✓	✓	✓	Exists unconditionally
53	RTDL	✓	✓	✓	Exists unconditionally
54	RTDH	✓	✓	✓	Exists unconditionally
55	CJLO	✓	✓	✓	Exists unconditionally
56	CJHI	✓	✓	✓	Exists unconditionally
57	V1L	✓	✓	✓	Exists unconditionally
58	V1G	✓	✓	✓	Exists unconditionally
59	MA1L	✓	✓	✓	Exists unconditionally
60	MA1G	✓	✓	✓	Exists unconditionally

Register Address	Parameter Notation	L22	L62	L42	Existence Conditions
61	CJCL	✓	✓	✓	Exists unconditionally
62	CJCT	✓	✓	✓	Exists unconditionally
63	T.ABN	✓	✓	✓	Exists unconditionally
64	PV	✓	✓	✓	Exists unconditionally
65	HSV1	✓	✓	✓	Exists unconditionally
66	LSV1	✓	✓	✓	Exists unconditionally
67	PV.HI	✓	✓	✓	Exists unconditionally
68	PV.LO	✓	✓	✓	Exists unconditionally
69	EROR	✓	✓	✓	Exists unconditionally
70	MODE	✓	✓	✓	Exists unconditionally
71	PROG	✓	✓	✓	Exists unconditionally
72	CMND	✓	✓	✓	Exists unconditionally
73	JOB1	✓	✓	✓	Exists unconditionally
74	JOB2	✓	✓	✓	Exists unconditionally
75	JOB3	✓	✓	✓	Exists unconditionally
76	SEL1	✓	✓	✓	Exists unconditionally
77	SEL2	✓	✓	✓	Exists unconditionally
78	SEL3	✓	✓	✓	Exists unconditionally
79	SEL4	✓	✓	✓	Exists unconditionally
80	SEL5	✓	✓	✓	Exists unconditionally
81					
82					
83					
84					
85	PASS	✓	✓	✓	Exists unconditionally
86	KPAS	✓	✓	✓	Exists unconditionally
87	CODE	✓	✓	✓	Exists if CODE is 0 or 500, or CODE equal to PASS
88	KCOD	✓	✓	✓	Exists if CODE is 0 or 500, or CODE equal to PASS
128	PV	✓	✓	✓	Exists unconditionally
129	HSV1	✓	✓	✓	Exists unconditionally
130	LSV1	✓	✓	✓	Exists unconditionally
131	T.ABN	✓	✓	✓	Exists unconditionally
132	MODE	✓	✓	✓	Exists unconditionally
133	PWRU	✓	✓	✓	Exists unconditionally
134					
135					
136					
137					
138					
139	EROR	✓	✓	✓	Exists unconditionally
140	PROG	✓	✓	✓	Exists unconditionally
141					
142	CMND	✓	✓	✓	Exists unconditionally
143	JOB1	✓	✓	✓	Exists unconditionally

1-2 Parameter Availability Table

1.10 Parameters Description

Modbus Register Address	Parameter Notation	Parameter Description	Range	Default Value	Data Access Type	Scale	
						Low	High
0	HSP1	High Limit Set Point1	Low: HSP.L High: HSP.H	100.0°C (212.0°F)	R/W	-19999	45536
1	LSP1	Low Limit Set Point1	Low: LSP.L High: LSP.H	0.0°C (32.0°F)	R/W	-19999	45536
2	HSP2	High Limit Set Point2	Low: -19999 High :45536	110.0°C (230.0°F)	R/W	-19999	45536
3	LSP2	Low Limit Set Point2	Low: -19999 High :45536	-10.0°C (14.0°F)	R/W	-19999	45536
4	HSP3	High Limit Set Point3	Low: -19999 High :45536	90.0°C (194.0°F)	R/W	-19999	45536
5	LSP3	Low Limit Set Point3	Low: -19999 High :45536	-50.0°C (-58.0°F)	R/W	-19999	45536
6	INPT	Input sensor selection	0 J_tC: J type Thermocouple 1 K_tC: K type Thermocouple 2 t_tC: T type Thermocouple 3 E_tC: E type Thermocouple 4 b_tC: B type Thermocouple 5 R_tC: R type Thermocouple 6 S_tC: S type Thermocouple 7 N_tC: N type Thermocouple 8 L_tC: L type Thermocouple 9 U_tC: U type Thermocouple 10 P_tC: P type Thermocouple 11 C_tC: C type Thermocouple 12 d_tC: D type Thermocouple 13 Pt.dN: PT100 Ω DIN curve 14 Pt.JS: PT100 Ω JIS curve 15 4-20: 4-20mA linear current 16 0-20: 0-20mA linear current 17 0-5V: 0-5VDC linear voltage 18 1-5V: 1-5VDC linear voltage 19 0-10: 0-10VDC linear voltage 20 0-50: 0-50mVDC linear voltage	1	R/W	0	65535
7	UNIT	Input unit selection	0 oC: °C unit 1 oF: °F unit 2 Pu: Process unit	0	R/W	0	65535
8	DP	Decimal point selection	0 No.dP: No decimal point 1 1-dP: 1 decimal digit 2 2-dP: 2 decimal digits 3 3-dP: 3 decimal digits	1	R/W	0	65535
9	INLO	Input low scale value	Low: -19999 High: 45536	-17.8°C (0.0°F)	R/W	-19999	45536
10	INHI	Input high scale value	Low: -19999 High: 45536	93.3°C (200.0°F)	R/W	-19999	45536
11	HSPL	Low limit of high limit set point value	Low: -19999 High: HSPH	0.0°C (32.0°F)	R/W	-19999	45536

Modbus Register Address	Parameter Notation	Parameter Description	Range	Default Value	Data Access Type	Scale	
						Low	High
12	HSPH	High limit of high limit set point value	Low: HSPL High: 45536	500.0°C (932.0°F)	R/W	-19999	45536
13	LSPL	Low limit of low limit set point value	Low: -19999 High: LSPH	-100.0°C (-148.0°F)	R/W	-19999	45536
14	LSPH	High limit of low limit set point value	Low: LSPL High: 45536	0.0°C (32.0°F)	R/W	-19999	45536
15	FILT	Filter damping time constant of PV	0 0: 0 second time constant 1 0.2: 0.2 second time constant 2 0.5: 0.5 second time constant 3 1: 1 second time constant 4 2: 2 second time constant 5 5: 5 second time constant 6 10: 10 second time constant 7 20: 20 second time constant 8 30: 30 second time constant 9 60: 60 second time constant	2	R/W	0	65535
16	DISP	Normal display format	0 SAFE : Display SAFE 1 HSP1 : Display HSP1 value 2 LSP1 : Display LSP1 value	1	R/W	0	65535
17	OUT1	Output 1 function	0 HI : High Limit Control 1 LO : Low Limit Control 2 HL : High / Low Limit Control	0	R/W	0	65535
18	O1HY	Output Hysteresis	Low: 0.1°C (0.2°F) High: 50.0°C (90.0°F)	0.1°C (0.2°F)	R/W	0	65535
19	OUT2	Output 2 function	0 NoNE : Output2 turned off 1 DCPS : DC Power Supply 2 AL1 : Alarm 1 Function 3 L_An : Limit Annunciator	2	R/W	0	65535
20	A1FN	Alarm 1 function for alarm 1 output	0 NoNE : No alarm function 1 PV.HI : Process value high alarm 2 PV.Lo : Process value low alarm	2	R/W	0	65535
21	A1MD	Alarm 1 operation mode	0 NoRM : Normal alarm action 1 LtCH : Latching alarm action 2 NoR.R : Normal alarm reverse action 3 LtC.R : Latching alarm reverse action	0	R/W	0	65535
22	A1HY	Alarm 1 Hysteresis control	Low: 0.1°C High: 50.0°C(90.0°F)	0.1°C (0.2°F)	R/W	0	65535
23	A1FT	Alarm 1 failure transfer mode	0 oFF : Alarm output OFF if the sensor fails 1 oN : Alarm output ON if the sensor fails	1	R/W	0	65535
24	A1SP	Alarm 1 set point	Low: -19999 High: 45536	100.0°C (212.0°F)	R/W	-19999	45536

Modbus Register Address	Parameter Notation	Parameter Description	Range	Default Value	Data Access Type	Scale	
						Low	High
25	A2FN	Alarm 2 functions for alarm 2 output	Same as A1FN	2	R/W	0	65535
26	A2MD	Alarm 2 operation mode	Same as A1MD	0	R/W	0	65535
27	A2HY	Alarm 2 Hysteresis control	Low: 0.1°C High: 50.0°C(90.0°F)	0.1° C (0.2° F)	R/W	0	65535
28	A2FT	Alarm 2 failure transfer mode	0 oFF : Alarm output OFF if the sensor fails 1 oN : Alarm output ON if the sensor fails	1	R/W	0	65535
29	A2SP	Alarm 2 set point	Low: -19999 High: 45536	100.0 °C (212.0°F)	R/W	-19999	45536
30	A3FN	Alarm 3 functions for alarm 3 output	Same as A1FN	2	R/W	0	65535
31	A3MD	Alarm 3 operation mode	Same as A1MD	0	R/W	0	65535
32	A3HY	Alarm 3 Hysteresis control	Low: 0.1°C High: 50.0°C(90.0°F)	0.1°C (0.2°F)	R/W	0	65535
33	A3FT	Alarm 3 failure transfer mode	0 oFF : Alarm output OFF if the sensor fails 1 oN : Alarm output ON if the sensor fails	1	R/W	0	65535
34	A3SP	Alarm 3 set point	Low: -19999 High: 45536	100.0°C (212.0°F)	R/W	-19999	45536
35	OFS1	Option1	<u>L62/ L42:</u> 0 NoNE : Not selected 1 R485 : RS-485 <u>L22:</u> 0 NoNE : Not selected 1 R485 : RS-485 2 E11 : Event 1 input	0	R/W	0	65535

Modbus Register Address	Parameter Notation	Parameter Description	Range	Default Value	Data Access Type	Scale	
						Low	High
36	OFS2	Option 2	<u>L42:</u> 0 NoNE: Not selected <u>L62:</u> 1 NoNE: Not selected 2 EI1.2: Event input 1 and Event input 2 <u>L22:</u> 0. NoNE: No selected 1. 4-20: 4-20mA retransmission output 2. 0-20: 0-20mA retransmission output 3. 0-5V: 0-5V retransmission output 4. 1-5V: 1-5V retransmission output 5. 0-10: 0-10 retransmission output 6. AL2: Alarm 2 output 7. EI2: Event2 Input	0	R/W	0	65535
37	OFS3	Option 3	<u>L42:</u> 0 NoNE: Not selected 1 4-20: 4-20mA retransmission output 2 0-20: 0-20mA retransmission output 3 0-5V: 0-5VDC retransmission output 4 1-5V: 1-5VDC retransmission output 5 0-10: 0-10VDC retransmission output <u>L62:</u> 6 NoNE: Not selected 7 4-20: 4-20mA retransmission output 8 0-20: 0-20mA retransmission output 9 0-5V: 0-5VDC retransmission output 10 1-5V: 1-5VDC retransmission output 11 0-10: 0-10VDC retransmission output 12 AL3: Alarm 3 output	0	R/W	0	65535

Modbus Register Address	Parameter Notation	Parameter Description	Range	Default Value	Data Access Type	Scale	
						Low	High
38	E1FN	Event input 1 function	0 <i>None</i> : none 1 <i>LOCK</i> : Remote Lock 2 <i>RRST</i> : Remote Reset 3 <i>HSP2</i> : HSP2 activated to replace HSP1 4 <i>LSP2</i> : LSP2 activated to replace LSP1 5 <i>HLS2</i> : HSP2 & LSP2 activated to replace HSP1 & LSP1 6 <i>HSP3</i> : HSP3 activated to replace HSP1 7 <i>LSP3</i> : LSP3 activated to replace LSP1 8 <i>HLS3</i> : HSP3 & LSP3 activated to replace HSP1 & LSP1 9 <i>rS.A1</i> : Reset alarm 1 output 10 <i>rS.A2</i> : Reset alarm 2 output 11 <i>rS.A3</i> : Reset alarm 3 output 12 <i>rS.Ao</i> : Reset all alarm outputs 13 <i>CA.LH</i> : Cancel alarm latch 14 <i>R.REF</i> : Reset Reference Data <i>E1FN ≠ E2FN, except selects NONE</i>	0	R/W	0	65535
39	E2FN	Event input 2 function	Same as E1FN <i>E1FN ≠ E2FN, except selects NONE</i>	0	R/W	0	65535
40	RETY	Retransmission type	0 <i>PV</i> : Retransmit Process Value 1 <i>HSP</i> : Retransmit HSP1 2 <i>LSP</i> : Retransmit LSP1	0	R/W	0	65535
41	RELO	Retransmission low scale value	Low: -19999 High: 45536	0.0°C (32.0°F)	R/W	-19999	45536
42	REHI	Retransmission high scale value	Low: -19999 High: 45536	100.0 °C (212.0 °F)	R/W	-19999	45536
43	ADDR	Address assignment of digital communication	Low: 1 High: 255	-----	R/W	0	65535

Modbus Register Address	Parameter Notation	Parameter Description	Range	Default Value	Data Access Type	Scale	
						Low	High
44	BAUD	Baud rate of digital communication	0 2K4: 2.4 Kbits/s baud rate 1 4K8: 4.8 Kbits/s baud rate 2 9K6: 9.6 Kbits/s baud rate 3 14K4: 14.4 Kbits/s baud rate 4 19K2: 19.2 Kbits/s baud rate 5 28K8: 28.8 Kbits/s baud rate 6 38K4: 38.4 Kbits/s baud rate 7 57K6: 57.6 Kbits/s baud rate 8 115K: 115.2 Kbits/s baud rate	2	R/W	0	65535
45	PARI	The parity bit of digital communication	0 EVEN: Even Parity 1 Odd: Odd parity 2 NoNE: No parity bit	0	R/W	0	65535
46	OFTL	Offset value for low point calibration	Low: -1999 High: 1999	0	R/W	-19999	45536
47	OFTH	Offset value for high point calibration	Low: -1999 High: 1999	0	R/W	-19999	45536
48	CALO	Input signal value during low point calibration	Low: -19999 High: CAHI-1 CALO≠CAHI	0	R/W	-19999	45536
49	CAHI	Input signal value during high point calibration	Low: CALO+1 High: 45536 CALO≠CAHI	1000	R/W	-19999	45536
50							
51	ADLO	mV calibration low coefficient	Low: -1999 High: 1999	-----	R/W	-19999	45536
52	ADHI	mV calibration high coefficient	Low: -1999 High: 1999	-----	R/W	-19999	45536
53	RTDL	RTD calibration low coefficient	Low: -1999 High: 1999	-----	R/W	-19999	45536
54	RTDH	RTD calibration high coefficient	Low: -1999 High: 1999	-----	R/W	-19999	45536
55	CJLO	Cold junction calibration low coefficient	Low: -5.00 High: 40.00	-----	R/W	-19999	45536
56	CJHI	Cold junction calibration high coefficient	Low: -1999 High: 1999	-----	R/W	-19999	45536
57	V1L	V1 calibration low coefficient	Low: -1999 High: 1999	-----	R/W	-19999	45536
58	V1G	V1 calibration high coefficient	Low: -1999 High: 1999	-----	R/W	-19999	45536
59	MA1L	MA1 calibration low coefficient	Low: -1999 High: 1999	-----	R/W	-19999	45536

Modbus Register Address	Parameter Notation	Parameter Description	Range	Default Value	Data Access Type	Scale	
						Low	High
60	MA1G	MA1 calibration high coefficient	Low: -1999 High: 1999	-----	R/W	-19999	45536
61	CJCL	Sensor voltage during cold junction calibration low	Low: 0 High: 7552	-----	R	0	65535
62	CJCT	Cold Junction Temperature	Low: -4000 High: 9000	-----	R	-19999	45536
63	T.ABN	Accumulated time during abnormal condition	Low: 0.0 High: 6553.5 Minutes	-----	R	0	65535
64	PV	Current Process value	Low: -19999 High: 45536	-----	R	-19999	45536
65	HSV1	Current High Limit Set point value	Low: SP1L High: SP1H	-----	R	-19999	45536
66	LSV1	Current Low Limit Set point value	Low: SP1L High: SP1H	-----	R	-19999	45536
67	PV.HI	Historical Maximum. Value of PV	Low: -19999 High: 45536	-----	R	-19999	45536
68	PV.LO	Historical Minimum. Value of PV	Low: -19999 High: 45536	-----	R	-19999	45536
69	EROR	Error code	Low: 0 High: 65535	-----	R	0	65535
70	MODE	Operation mode & alarm status	Low: 0 High: 65535	-----	R	0	65535
71	PROG	Program code	L42:45. XX L62:64. XX L22:26. XX	-----	R	0	65535
72	CMND	Command code	Low: 0 High: 65535	-----	R/W	0	65535
73	JOB1	Job code	Low: 0 High: 65535	-----	R/W	0	65535
74	JOB2	Job code	Low: 0 High: 65535	-----	R/W	0	65535
75	JOB3	Job code	Low: 0 High: 65535	-----	R/W	0	65535

Modbus Register Address	Parameter Notation	Parameter Description	Range	Default Value	Data Access Type	Scale	
						Low	High
76	SEL1	1'st parameter for the user menu	0 NoNE: No Parameter 1 dISP: DISP 2 o1HY: O1HY 3 A1HY: A1HY 4 A1SP: A1SP 5 A2HY: A2HY 6 A2SP: A2SP 7 OFTL: OFTL 8 OFTH: OFTH 9 CALO: CALO 10 CAHI: CAHI 11 A3HY: A3HY (Not Exists in L22) 12 A3SP: A3SP (Not Exists in L22)	0	R/W	0	65535
77	SEL2	2'nd parameter for the user menu	Same as SEL1	0	R/W	0	65535
78	SEL3	3'rd parameter for the user menu	Same as SEL1	0	R/W	0	65535
79	SEL4	4'th parameter for the user menu	Same as SEL1	0	R/W	0	65535
80	SEL5	5'th parameter for the user menu	Same as SEL1	0	R/W	0	65535
81							
82							
83							
84							
85	PASS	Password entry	Low: 0 High: 9999	0	R/W	-32768	32767
86	KPAS	Calibration Password entry	Low: 0 High: 9999	0	R/W	-32768	32767
87	CODE	Security code for parameter protection	Low: 0 High: 9999 Refer Chapter 3.1 for more details	0	R/W	-32768	32767
88	KCOD	Security code for calibration protection	Low: 0 High: 9999	0	R/W	-32768	32767
128	PV	Current Process value	Low: -19999 High: 45536	-----	R	-19999	45536
129	HSV1	Current High Limit Set point value	Low: SP1L High: SP1H	-----	R	-19999	45536

Modbus Register Address	Parameter Notation	Parameter Description	Range	Default Value	Data Access Type	Scale	
						Low	High
130	LSV1	Current Low Limit Set point value	Low: SP1L High: SP1H	-----	R	-19999	45536
131	T.ABN	Accumulated time during abnormal condition	Low: 0.0 High: 6553.5 Minutes	-----	R	0	65535
132	MODE	Operation mode & alarm status	Low: 0 High: 65535	-----	R	0	65535
133	PWRU	Power-Up Logic	0 NoRM :Normal 1 RST : Reset 2 NoRL : Normal Latch	0	R/W	0	65535
134							
135							
136							
137							
138							
139	EROR	Error code	Low: 0 High: 65535	-----	R	0	65535
140	PROG	Program code	L42 :45. XX L62 :64. XX L22 :26. XX	-----	R	0	65535
141							
142	CMND	Command code	Low: 0 High: 65535	-----	R/W	0	65535
143	JOB1	Job code	Low: 0 High: 65535	-----	R/W	0	65535

2 Installation and Wiring

 Sometimes dangerous voltages capable of causing death are present in this instrument. Before doing the installation or any troubleshooting procedures, the power to the equipment must be switched off and isolated. Units suspected of being faulty must be disconnected and removed to a properly equipped workshop for testing and repair. Component replacement and internal adjustments must be made by a qualified maintenance person only.

 To minimize the possibility of fire or shock hazards, do not expose this instrument to rain or excessive moisture.

 Do not use this instrument in areas under hazardous conditions such as excessive shock, vibration, dirt, moisture, corrosive gases or oil. The ambient temperature of the area should not exceed the maximum rating specified in the specification.

 Remove stains from this equipment using a soft, dry cloth. Do not use harsh chemicals, volatile solvents such as thinner or strong detergents to clean the equipment to avoid deformation.

 If the equipment is used in a manner not specified by the manufacturer, the protection provided by the equipment may be impaired.

2.1 Unpacking

Upon receipt of the shipment, remove the limit controller from the carton and inspect the unit for shipping damage. If any damage is found, contact your local representative immediately. Note the model number and serial number for future reference when corresponding with our service center. The serial number (S/N) is labeled on the box and the housing of the limit controller.

The limit controller is designed for indoor use only and is not intended for use in any hazardous area. It should be kept away from shock, vibration, and electromagnetic fields (such as variable frequency drives), motors and transformers. It is intended to operate under the following environmental conditions.

Environmental Parameter	Specification
Operating Temperature	-10°C to 50 °C
Humidity	0% to 90% RH (Non-condensing)
Altitude	2000 M Maximum

2-1 Environmental Specification

2.2 Mounting

Make the panel cut out as per the dimensions required by the limit controller. The dimensions of the different sizes of this series limit controller series are given in the following section. Remove the mounting clamps from the limit controller and insert the limit controller into the panel cut out. After inserting the limit controller into the panel cut out, re-install the mounting clamps. Gently tighten the clamp screws until the limit controller is properly secured into the cutout.

2.2.1 L42 Dimension

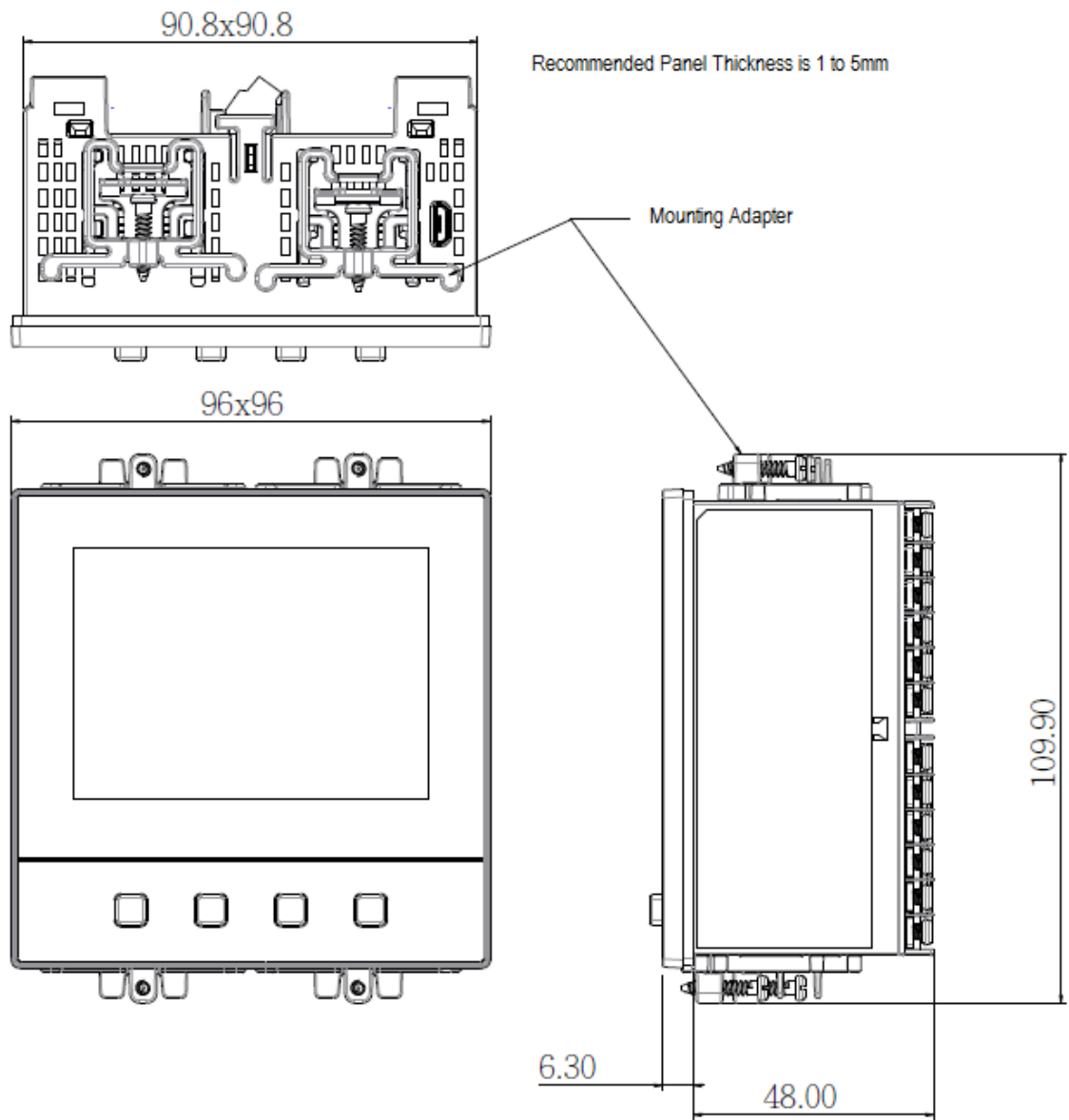

2-1 L42 Dimension with Clamps

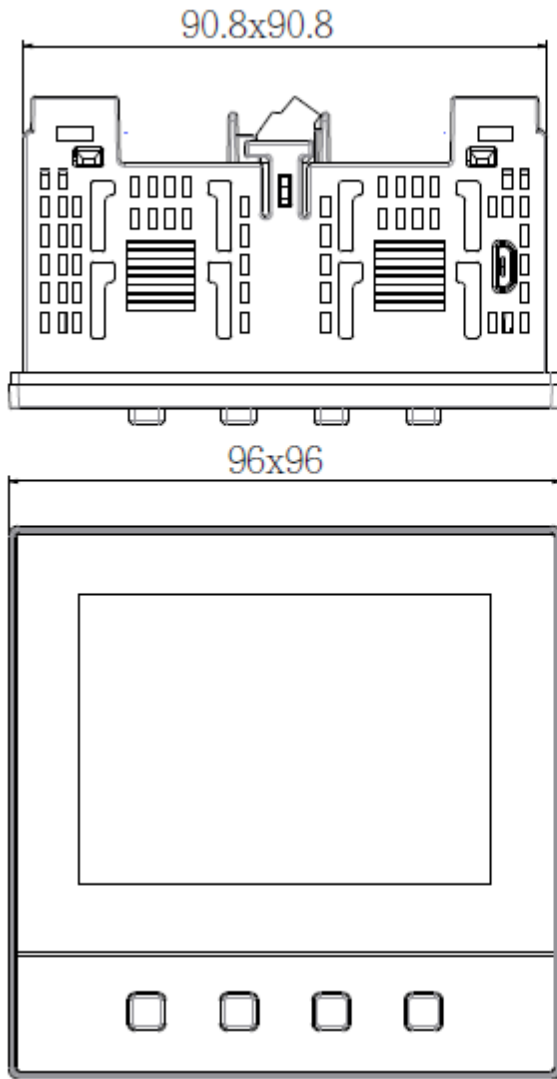

Recommended Panel Thickness is 1 to 5mm

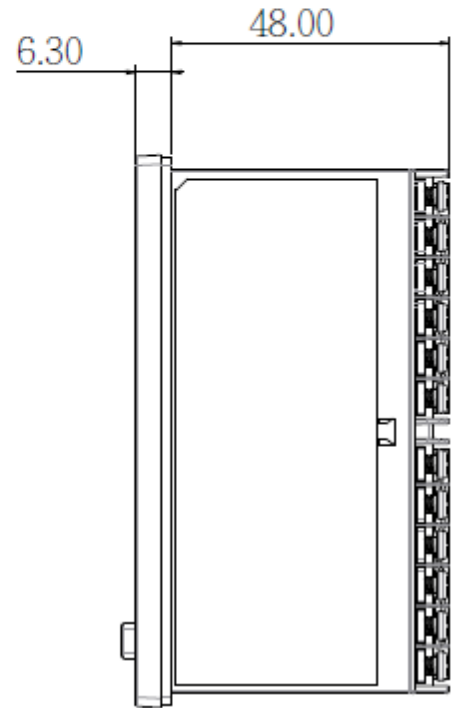

2-2 L42 Dimension without Clamp

2.2.2 L62 Dimension

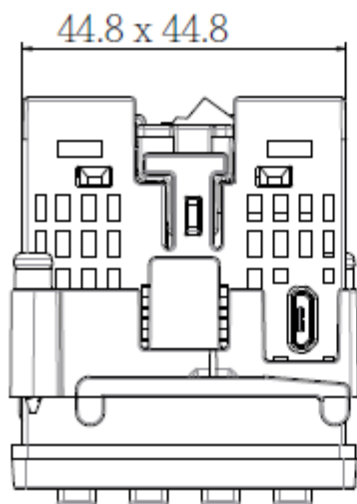

Recommended Panel Thickness is 1 to 5mm

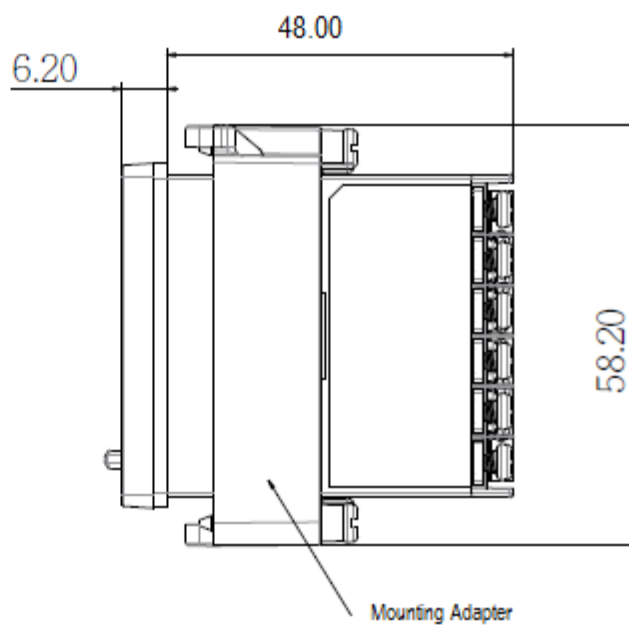

2-3 L62 Dimension with clamp

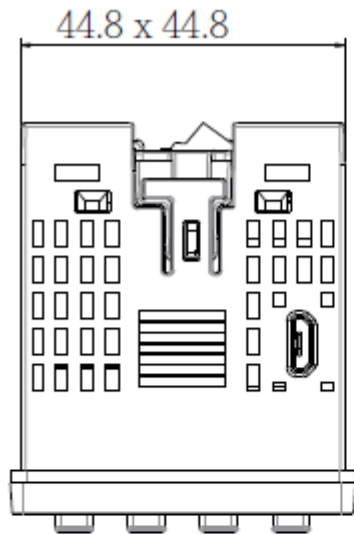

Recommended Panel Thickness is 1 to 5mm

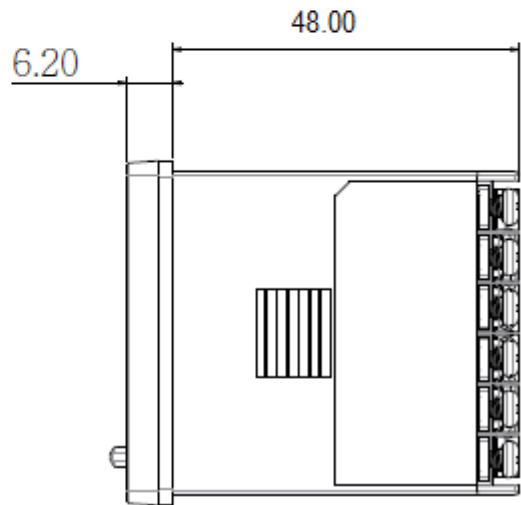
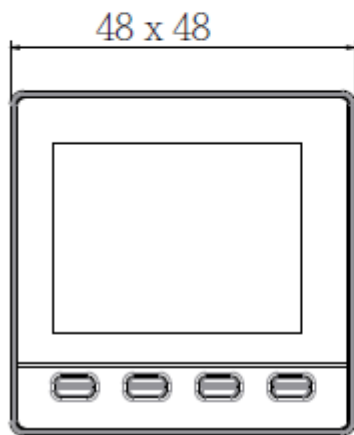

2-4 L62 Dimension without Clamp

2.2.3 L22 Dimension

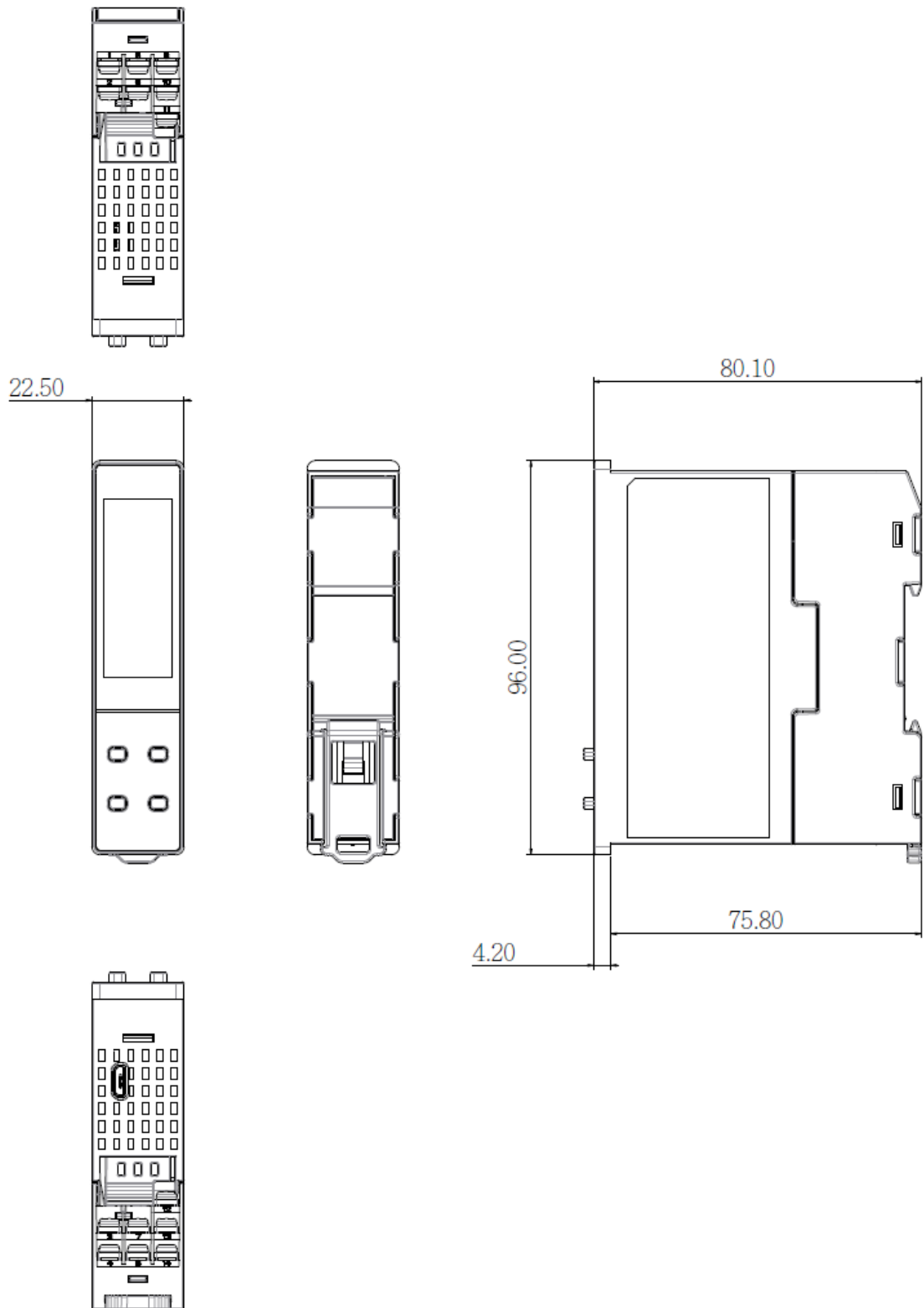

2-5 L22 Dimension

2.3 Wiring Precautions

- ⚠ Before wiring, verify the label for correct model number and options. Switch off the power when checking.
- ⚠ The utmost care must be taken to ensure that maximum voltage rating specified on the label are not exceeded.
- ⚠ All units should be installed inside a suitably grounded metal enclosure to prevent live parts being accessible from human hands and metal tools. Before powering on the limit controller, the equipment ground must be connected with a minimum of 1.6mm diameter conductor for protective grounding.
- ⚠ It is recommended that the supply power of these units be protected by fuses or circuit breakers rated at the lowest value possible
- ⚠ All wiring must conform to appropriate standards of good practice and local codes and regulations. Wiring must be suitable for maximum voltage, current, and temperature rating of the system.
- ⚠ Beware not to over-tighten the terminal screws. The torque should not exceed 1N-m (8.9 Lb-in or 10.2 Kg F-cm).
- ⚠ Unused control terminals should not be used as jumper points as they may be internally connected, causing damage to the unit.
- ⚠ Verify that the ratings of the output devices and the inputs as specified in [Chapter 1.4](#) are not exceeded.
- ⚠ Except the thermocouple wiring, all wiring should use stranded copper conductor with maximum gauge 18 AWG
- ⚠ To remove the dust please use the dry cloth.
- ⚠ Protection impairment if used in a manner not specified by the manufacturer.
- ⚠ Sometimes dangerous voltages capable of causing death are present in this instrument. Before doing the installation or any troubleshooting procedures, the power to the equipment must be switched off and isolated. Units suspected of being faulty must be disconnected and removed to a properly equipped workshop for testing and repair. Component replacement and internal adjustments must be made by a qualified maintenance person only.

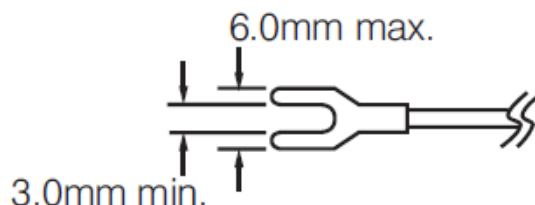

2-6 Lead Terminal

2.3.1 ZEL-L42 Terminal Connection

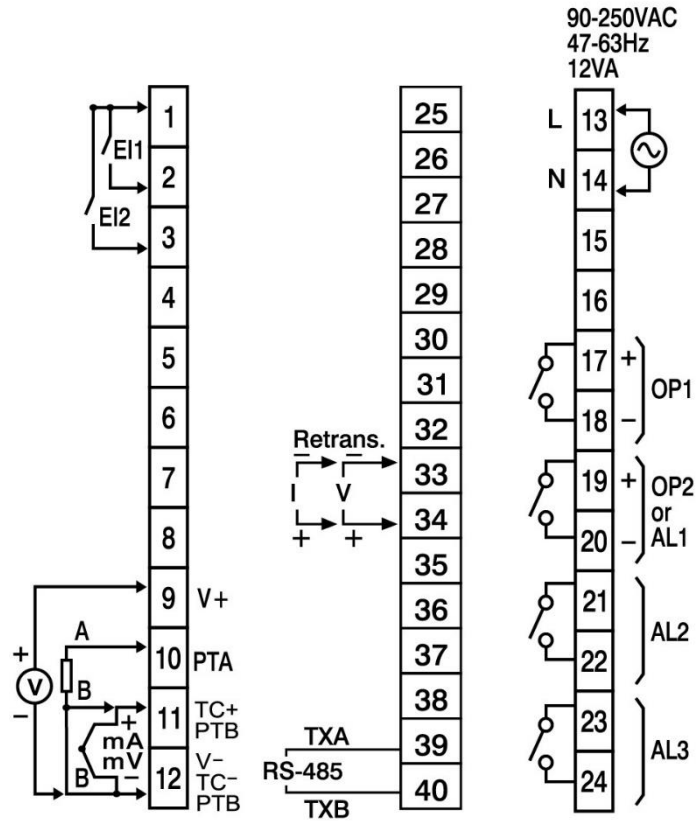

2-7 ZEL-L42 Rear Terminal Connection – High Voltage Input Power

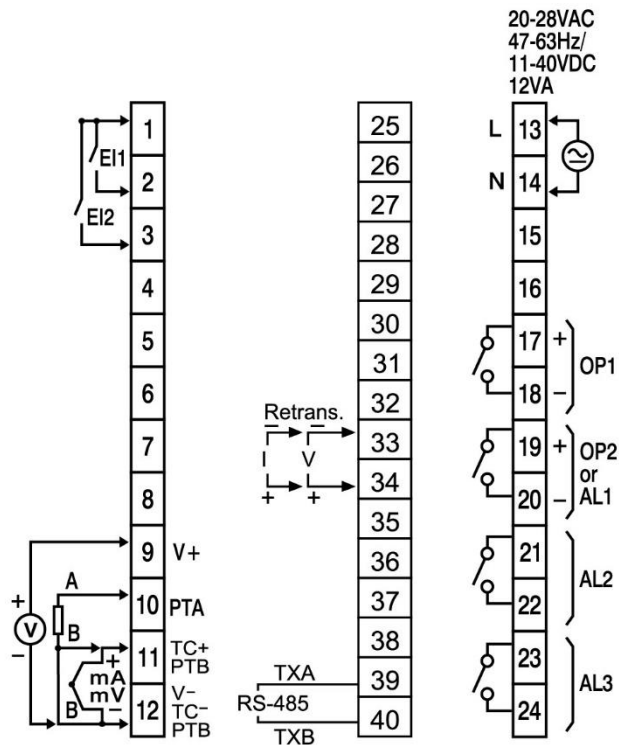

2-8 ZEL-L42 Rear Terminal Connection – Low Voltage Input Power

2.3.2 ZEL-L62 Terminal Connection

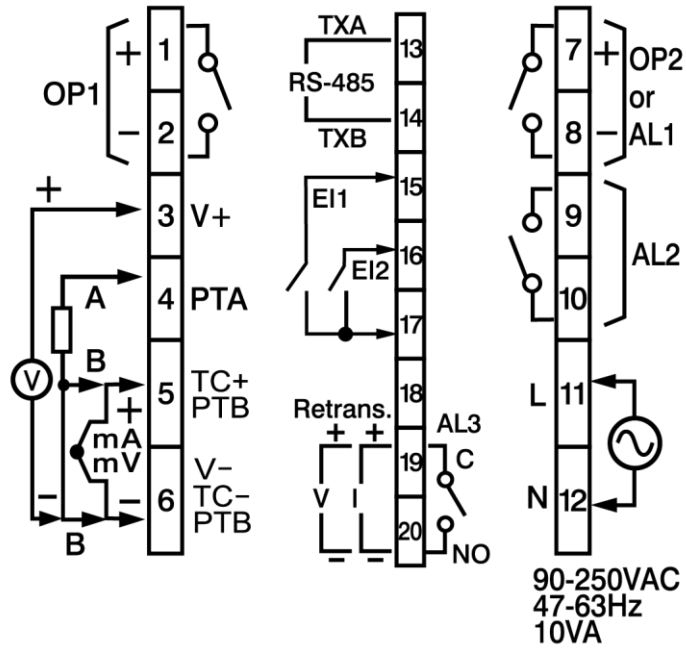

2-9 ZEL-L62 Rear Terminal Connection – High Voltage Input Power

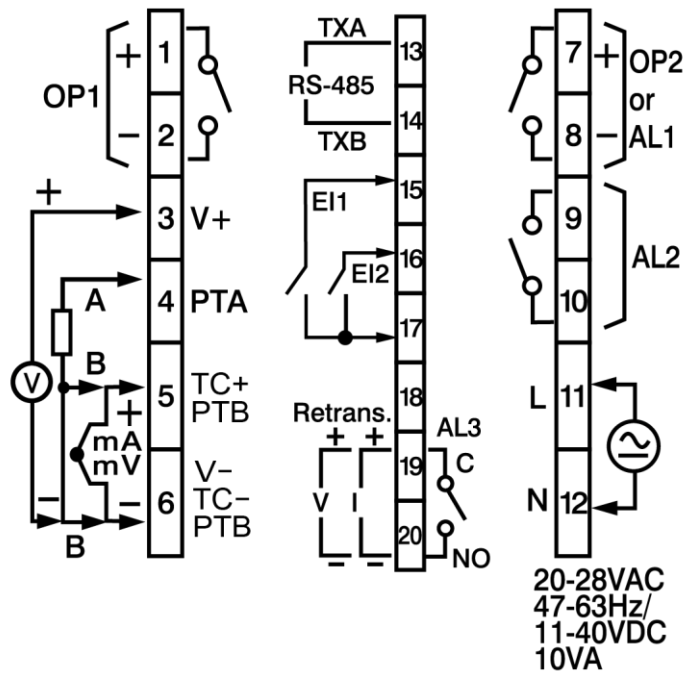

2-10 ZEL-L62 Rear Terminal Connection – Low Voltage Input Power

2.3.3 ZEL-L22 Terminal Connection

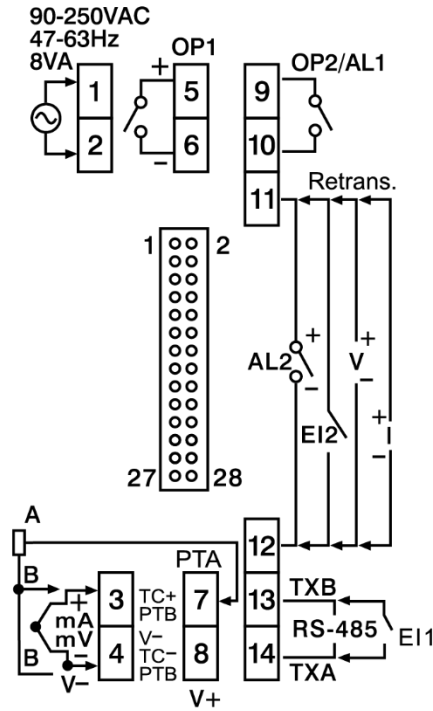

2-11 ZEL-L22 Terminal Connection– High Voltage Input Power

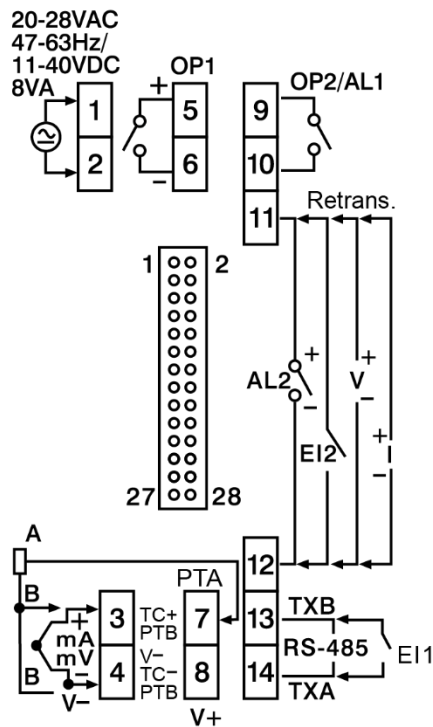

2-12 ZEL-L22 Terminal Connection– Low Voltage Input Power

2.4 Power Wiring

The limit controller is designed to operate at either 11-26VAC/VDC or 90-250VAC depending on power input option ordered. Check that the installation voltage corresponds with the power rating indicated on the product label before connecting power to the limit controller. Near the limit controller, a fuse and a switch rated at 2A/250VAC should be equipped as shown below.

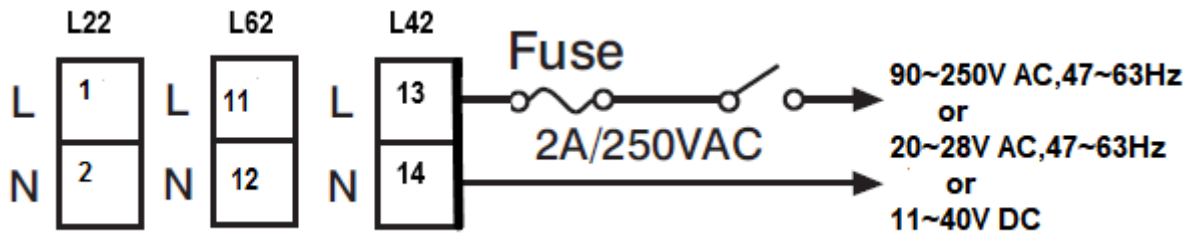

2-13 Power Wiring

- ⚠ This equipment is designed for installation in an enclosure which provides adequate protection against electric shock. The enclosure must be connected to earth ground.
- ⚠ Local requirements regarding electrical installation should be rigidly observed. Consideration should be given to prevent unauthorized persons from accessing the power terminals.

2.5 Sensor Installation

Proper sensor installation can eliminate many problems in a control system. The probe should be placed so that it can detect any temperature change with minimal thermal lag. In a process that requires fairly constant heat output, the probe should be placed close to the heater. In a process where the heat demand is variable, the probe should be closed to the work area. Some experiments with probe location are often required to find this optimum position.

In a liquid process, the addition of a stirrer or agitator can help to eliminate thermal lag. Since the thermocouple is a point measuring device, placing more than one thermocouple in parallel can provide average temperature readout and produce better results in most air heated processes.

The proper sensor type is also a very important factor to obtain precise measurements. The sensor must have the correct temperature range to meet the process requirements. In special processes, the sensor might need to have different requirements such as being leak-proof, ant vibration, antiseptic, etc.

Standard sensor limits of error are $\pm 4^{\circ}\text{F}$ ($\pm 2^{\circ}\text{C}$) or 0.75% of sensed temperature (half that for special) plus drift caused by improper protection or an over-temperature occurrence. This error is far greater than controller error and cannot be corrected on the sensor except by proper selection and replacement.

2.6 Sensor Input Wiring

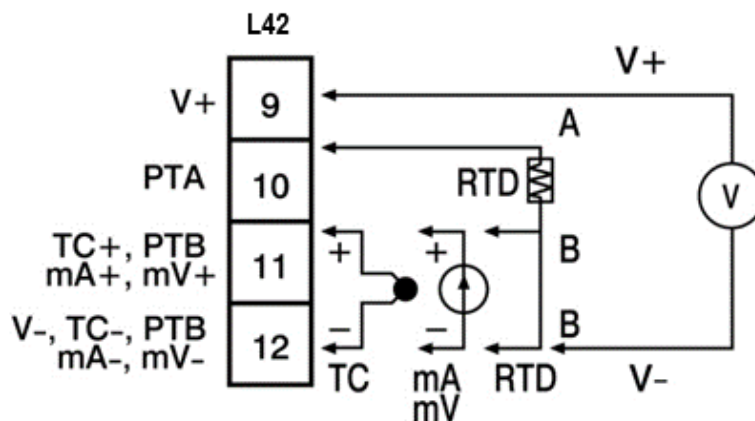

2-14 L42 Sensor Input Wiring

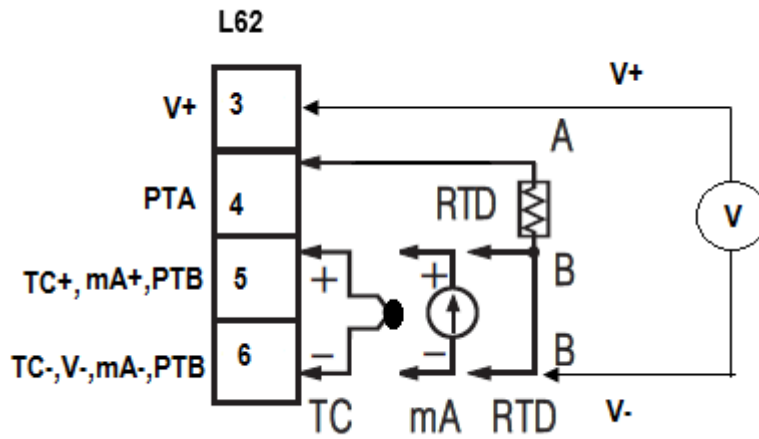

2-15 L62 Sensor Input Wiring

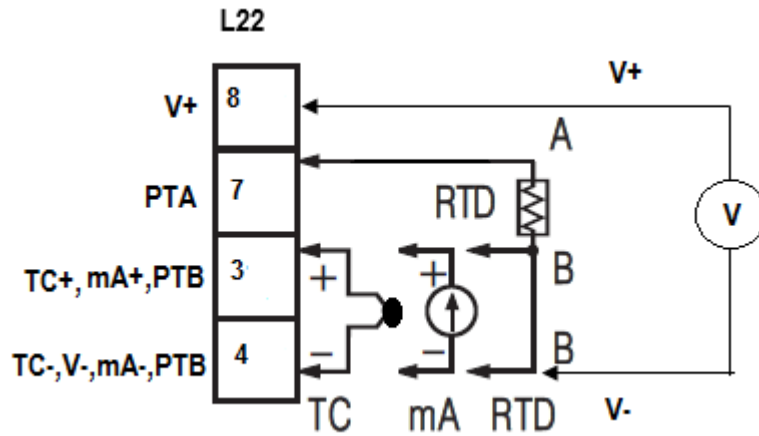

2-16 L22 Sensor Input Wiring

2.7 Limit Control Output Wiring

2.7.1 Output 1

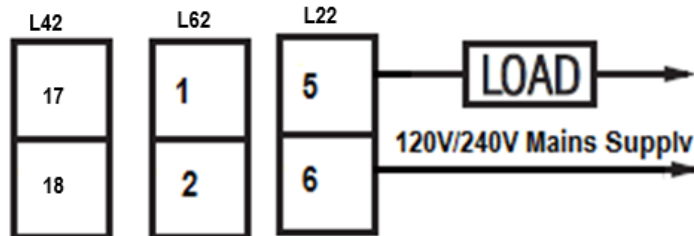

2-17 Output 1 Relay to Drive Load

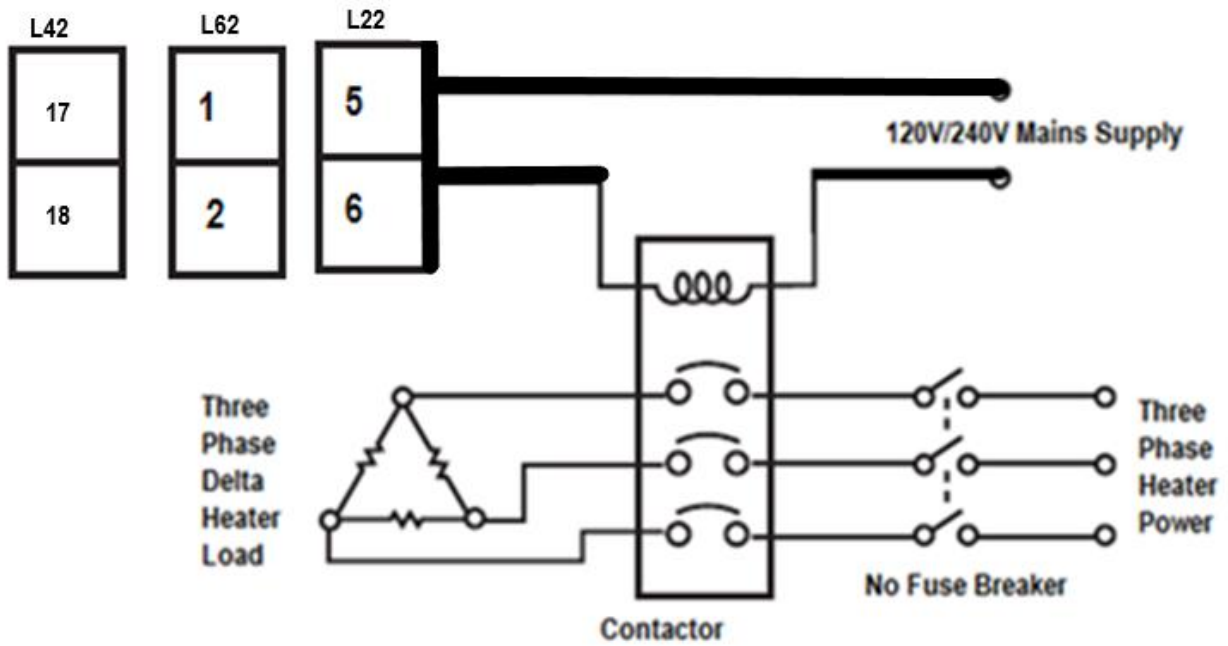

2-18 Output 1 Relay to Drive Contactor

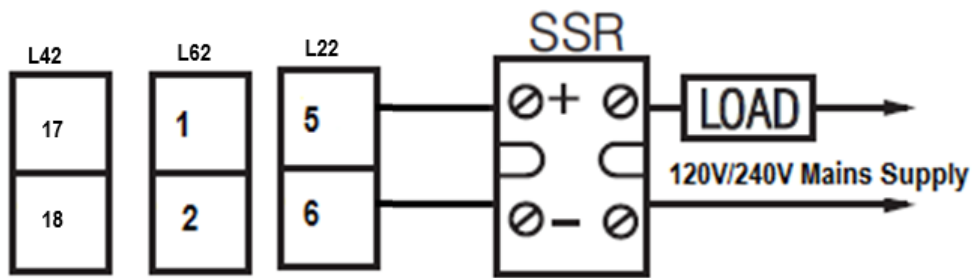

2-19 Output1 Pulsed voltage to Drive SSR

2.8 Alarm Wiring

2.8.1 Alarm 1(Output 2)

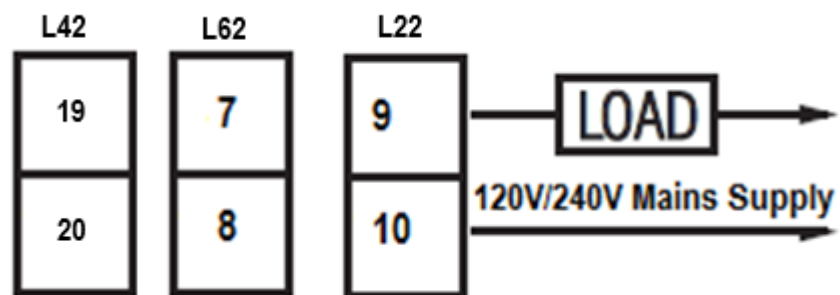

2-20 Alarm 1 Output to Drive Load

2.8.2 Alarm 2

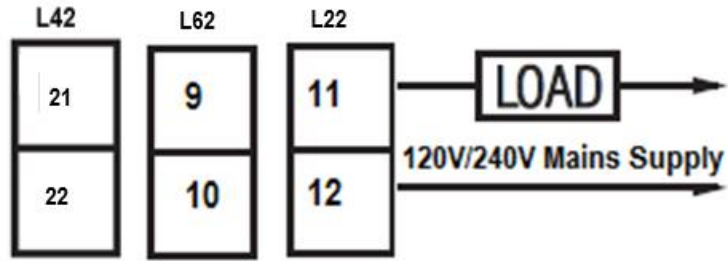

2-21 Alarm 2 Output to Drive Load

2.8.3 Alarm 3

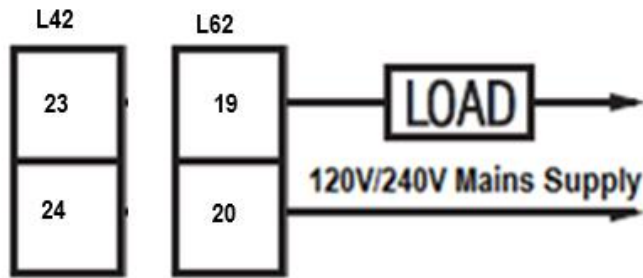

2-22 Alarm 3 Output to Drive Load

2.9 Event Input Wiring

The event input can accept a switch (dry contact) or an open collector signal. The event input function (EIFN) is activated as the switch is closed or an open collector (or a logic signal) is pulled down.

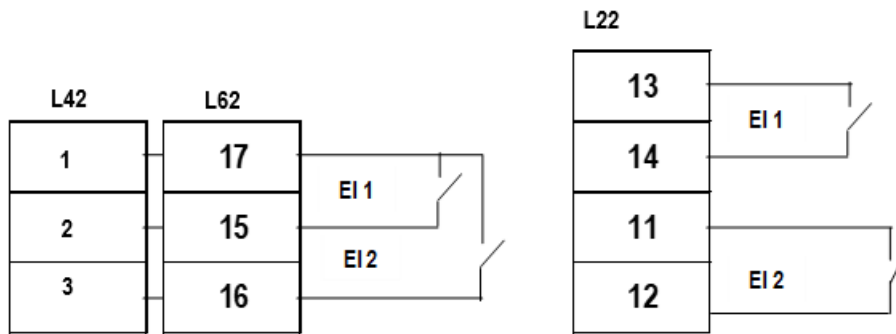

2-23 Event Input Wiring

2.10 Retransmission Wiring

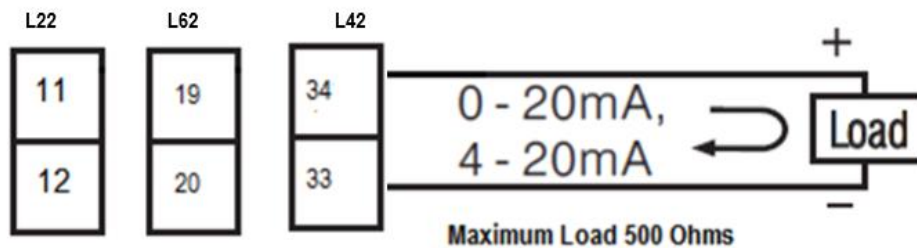

2-24 Retransmission Wiring - Current

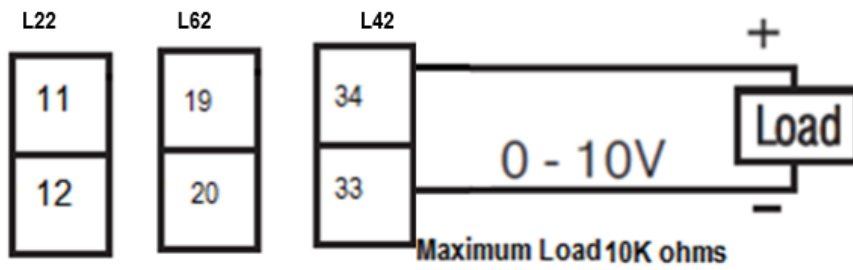

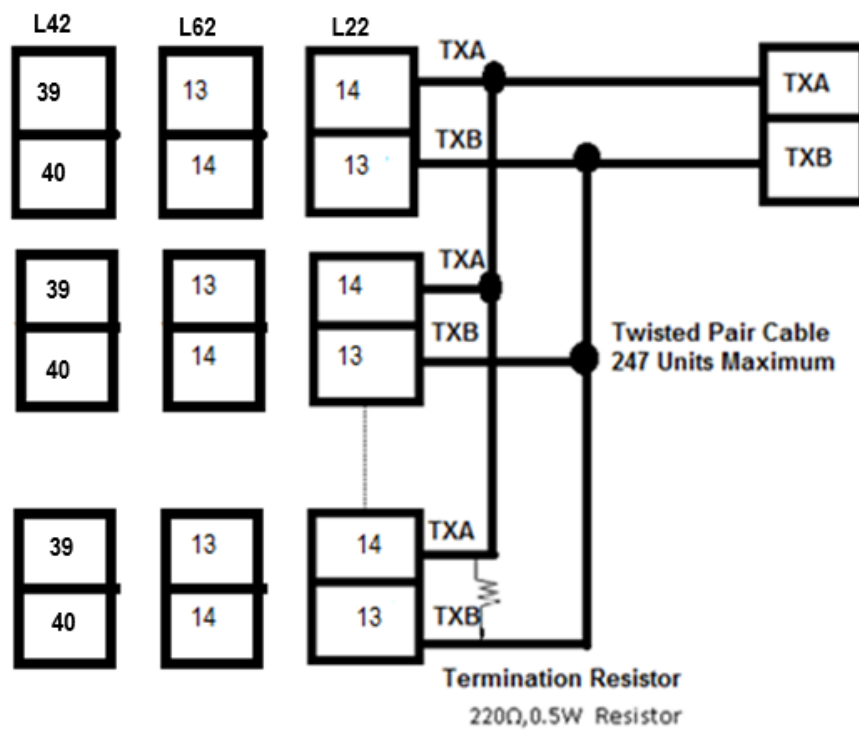

2-25 Retransmission Wiring - Voltage

2.11 RS-485 Data Communication



2-26 RS-485 Wiring

3 Programming

Press  for 5 seconds and release to enter the setup menu. Press and release  to select the desired parameter. The upper display indicates the parameter symbol, and the lower display indicates the value of the selected parameter.

3.1 User Security

There are two parameters PASS (password) and CODE (security code) which will control the data security function.

CODE Value	PASS Value	Access Rights
0	Any Value	All parameters are changeable
500	=500	All parameters are changeable
	≠500	All parameters are changeable except calibration parameters
1000	=1000	All parameters are changeable
	≠1000	User menu parameters only changeable
9999	=9999	All parameters are changeable except calibration parameters
	≠9999	HSP1 to HSP3 & LSP1 to LSP3 only changeable
Others	=CODE	All parameters are changeable
	≠CODE	No parameters can be changed

3-1 User Access Rights

Note:

- ❖ CODE parameter will not be visible when CODE≠PASS except the CODE value 0 and 500.
- ❖ If the user security is enabled, the controller will be automatically locked (logout) after a period of one minute idle time or when the power is disconnected. If the user needs to modify the parameters then the user needs to configure PASS=CODE to login again.
- ❖ If the Remote Lock is function is used with event input then the remote lock must be released to do changes on any of the parameters.
- ❖ The user needs to observe CODE, PASS logic for the remote lock operation. In addition, if remote is needed, it means the remote priority is higher than local. Local changes will be over-written by remote operations. If the code is equal to “0”, the remote LOCK feature won’t work

3.2 Calibration Security

The calibration of the device is protected with separate security access. There are two parameters KPAS (calibration password) and KCOD (calibration security code) which will control the data security of calibration parameters.

When KPAS = KCOD the user can modify the calibration parameters.

Value	KCOD	Value	KPAS	Access Rights
KCOD	KCOD	=KCOD		Calibration parameters are changeable
		≠KCOD		Calibration parameters can't be changed

3-2 Calibration Access Rights

3.3 Signal Input

INPT: Select the sensor type or signal type for signal input

Range: (Thermocouple) J_tC, K_tC, T_tC, E_tC, B_tC, R_tC, S_tC, N_tC, L_tC, U_tC, P_tC, C_tC, d_tC

(RTD) PT. DN, PT.JS
 (Linear) 4-20mA, 0-20mA, 0-5V, 1-5V, 0-10V, 0-50mV

UNIT: Select the processing unit

Range: °C, °F, PU (Process unit). If the unit is neither °C nor °F, then selects PU.

DP: Select the resolution of the process value.

Range: For Thermocouple and RTD Signal NO. DP, 1-DP and For Linear Signal NO. DP, 1- DP, 2-DP, 3-DP

INLO: Select the low scale value for the linear type input.

INHI: Select the high scale value for the linear type input.

How to use INLO and INHI:

If 4-20mA is selected for INPT, let SL represent the low scale of the input signal (i.e. 4 mA), let SH represent the high scale of the input signal (i.e. 20 mA). S represents the current input signal value; the conversion curve of the process value is shown as follows:

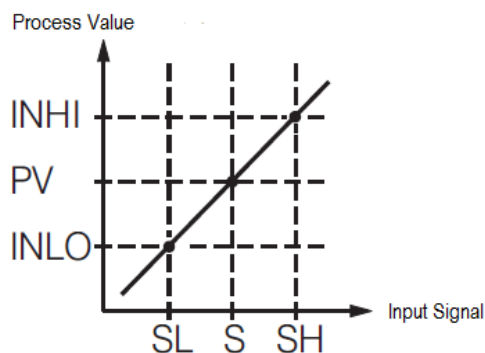

3-1 Conversion Curve for Linear Type Process Signal

Formula: $PV = INLO + (INHI - INLO) \cdot ((S - SL) / (SH - SL))$

Example: A 4-20mA current loop pressure transducer with a range of 0-15 kg/cm is connected to the input.

The following parameters should be set as follows:

INPT = 4-20, INLO = 0.00, INHI = 15.00, DP = 2-DP

Of course, the user may select a different value for DP to alter the resolution.

3.4 Limit Control Output

Select the output 1 function and hysteresis in OUT1 and O1HY.

OUT1: The available output 1 functions are: High Limit Control, Low Limit Control and High & Low Limit Control. Refer to [Section 1.3](#) for the limit control operation.

O1HY: Output 1 hysteresis value. The hysteresis value is adjusted to a proper value to eliminate the relay jitter in a noisy environment.

3.5 Set Point Range

The set point range can be configured with the following parameters.

HSP.L : Lower limit of high limit set point HSP1. Hidden if LO is selected for OUT1

HSP.H : Upper limit of high limit set point HSP1. Hidden if LO is selected for OUT1

LSP.L : Lower limit of low limit set point LSP1. Hidden if HI is selected for OUT1

LSP.H : Upper limit of low limit set point LSP1. Hidden if HI is selected for OUT1

HSP.L and HSP.H in setup menu are used to confine the adjustment range of high limit set point HSP1. LSP.L and LSP.H are used to confine the adjustment range of low limit set point LSP1.

3.6 Alarm

The limit controller has up to three alarm outputs depending on the limit controller model. There are 11 types of alarm functions that can be selected for these alarms. There are 6 kinds of alarm modes available for each alarm function.

3.6.1 Alarm Types

There are two different types of alarms as listed below that the user can assign to different alarm outputs.

1. **PV. Hi:** Process value high alarm
2. **PV. Lo:** Process value low alarm

A process alarm can set two absolute trigger levels. When the process value is higher than $AxSP$, a **process high alarm (PV. Hi)** occurs. The alarm is off when the process value is lower than $AxSP - AxHY$.

When the process value is lower than $AxSP$, a **process low alarm (PV. Lo)** occurs. The alarm is off when the process is higher than $AxSP + AxHY$. A process alarm is independent of the set point.

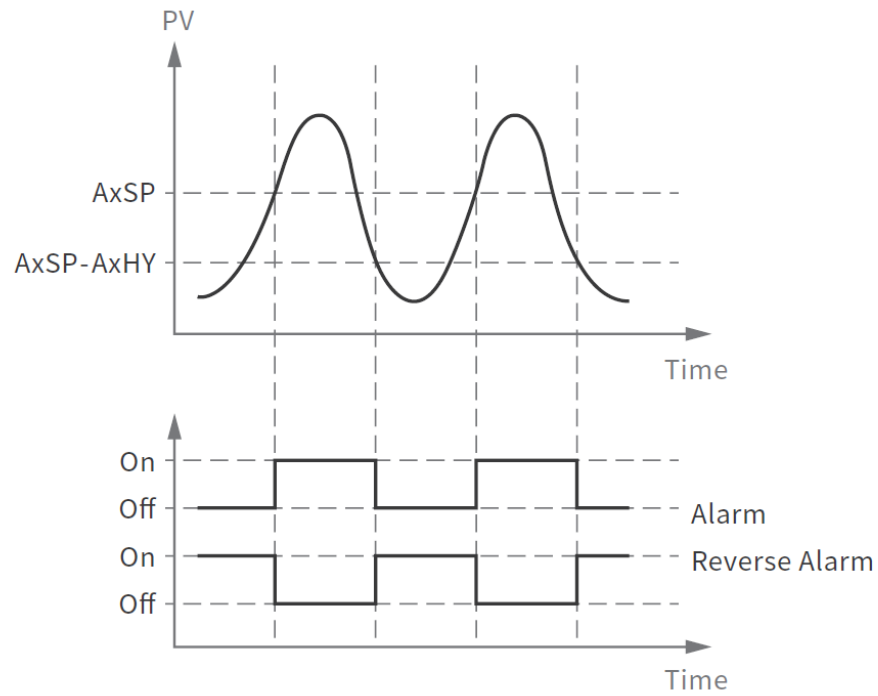

3-2 Process Value High (PV.HI)

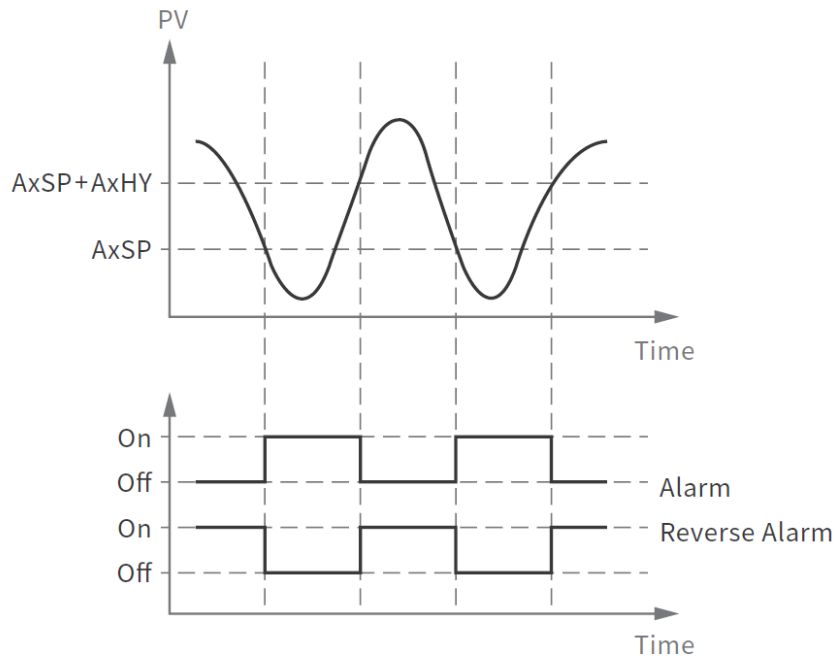

3-3 Process Value Low (PV.Lo)

3.6.2 Alarm Modes

There are six types of alarm modes available for each alarm function.

1. Normal alarm
2. Latching alarm
3. Normal Alarm Reverse Output
4. Latching Alarm Reverse Output

3.6.2.1 Normal Alarm: $ALMD = NoRM$

When a normal alarm is selected, the alarm output is de-energized in the non-alarm condition and energized in an alarm condition.

3.6.2.2 Latching Alarm: $ALMD = LtCH$

If a latching alarm is selected, once the alarm output is energized, it will remain unchanged even if the alarm condition is cleared. The latching alarm can be reset by pressing the RESET key once the alarm condition is removed.

3.6.2.3 Normal Alarm Reverse Output: $ALMD = NoR.R$

When a normal alarm reverse output is selected, the alarm output is energized in the non-alarm condition and de-energized in an alarm condition.

3.6.2.4 Latching Alarm Reverse Output: $ALMD = LtC.R$

If a latching alarm reverse output is selected, once the alarm output is de-energized, it will remain unchanged even if the alarm condition is cleared. The latching alarm can be reset (energized) by pressing the RESET key once the alarm condition is removed.

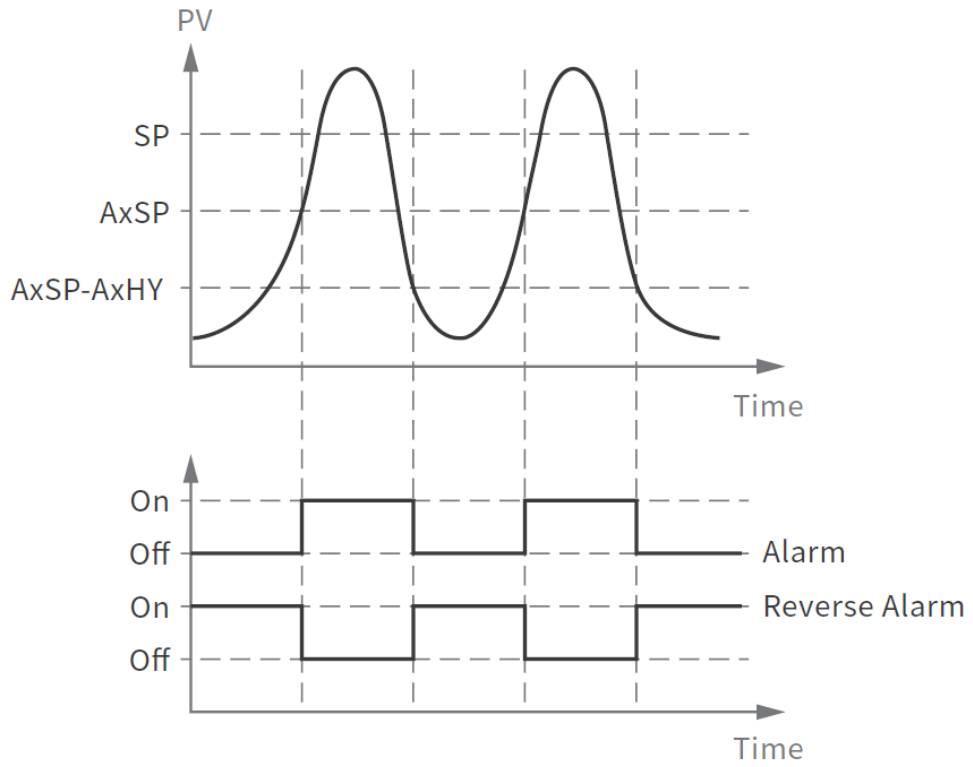

3-4 Process Value High- Normal Alarm

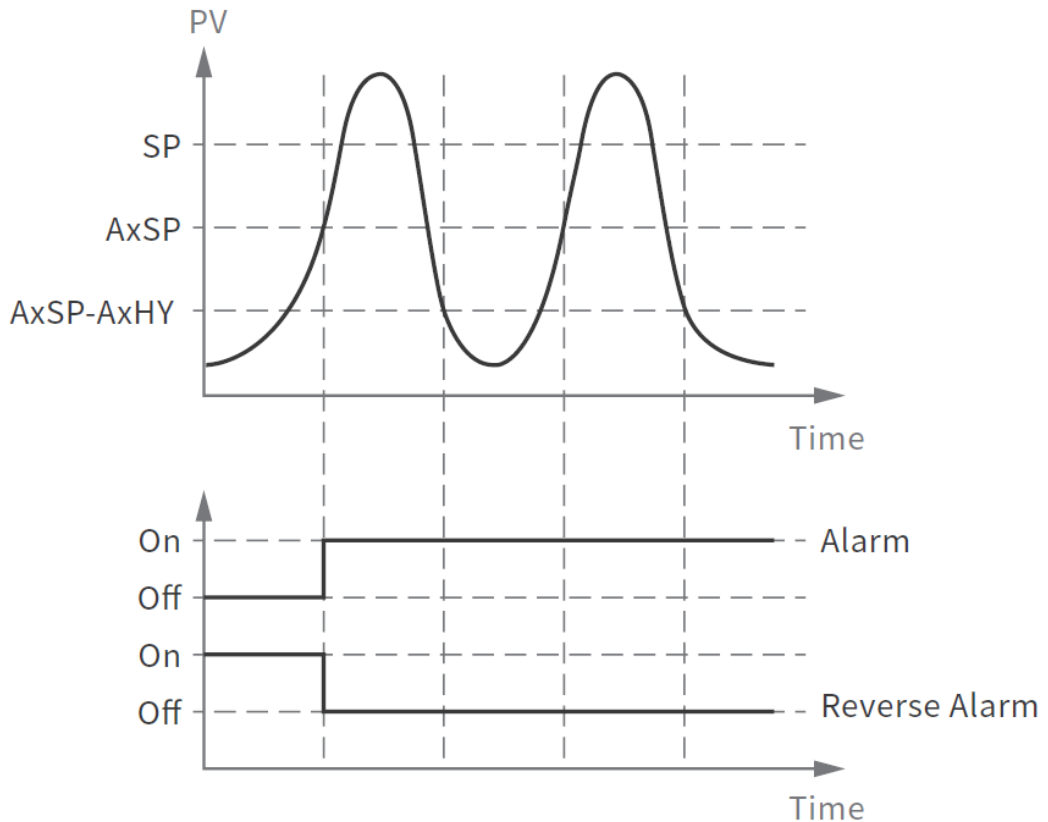

3-5 Process Value High- Latching Alarm

3.6.3 Alarm Failure Transfer

Alarm Failure transfer is activated as the unit enters failure mode. The respective Alarm will go on if ON is set for A1FT, A2FT or A3FT and will go off if OFF is set for A1FT, A2FT or A3FT. The unit will enter failure mode if a sensor break occurs or if the A-D converter fails.

3.7 User Select Menu Configuration

Conventional limit controllers are designed with parameters in a fixed order. If the user needs a friendlier menu operation to suit their application, most conventional limit controllers do not offer a solution. This series limit controllers have the flexibility for the user to select those parameters which are most significant and put these parameters in an easy access USER menu.

There are eight user-friendly parameters from the below list that can be set for user select menu configuration using the SEL1-SEL5 parameters.

0. **NoNE**: No Parameter
1. **dISP**: DISP
2. **o1HY**: O1HY
3. **A1HY**: A1HY
4. **A1SP**: A1SP
5. **A2HY**: A2HY
6. **A2SP**: A2SP
7. **OFTL**: OFTL
8. **OFTH**: OFTH
9. **CALO**: CALO
10. **CAHI**: CAHI
11. **A3HY**: A3HY (L62/L42 Only)
12. **A3SP**: A3SP (L62/L42 Only)

When using the up-down key to select parameters, all of the above parameters may not be available. The number of visible parameters is dependent on the setup configuration.

3.8 User Calibration or PV Shift

Each unit is calibrated in the factory before shipment. The user can still modify the calibration in the field.

The basic calibration of the limit controller is highly stable and set for life. User calibration allows the user to offset the permanent factory calibration to:

- ❖ Calibrate the limit controller to meet a user reference standard.
- ❖ Match the calibration of the limit controller to that of a particular transducer or sensor input.
- ❖ Calibrate the limit controller to suit the characteristics of a particular installation.
- ❖ Remove long term drift in the factory set calibration.

There are two parameters: Offset Low (OFTL) and Offset High (OFTH) for adjustment to correct an error in the process value. There are two parameters for the sensor input. These two signal values are CALO and CAHI. The input signal low and high values are to be entered in the CALO and CAHI parameters respectively.

Connect the input with low scale operating temperature (For Example 0.0). Enter the low scale operating temperature in CALO. For example, 0.0. Then monitor the PV. If $PV \neq CALO$, adjust the OFTL to make $PV=CALO$.

Connect the input with high scale operating temperature (For Example 700.0). Enter the high scale operating temperature in CAHI. For example, 700.0. Then monitor the PV. If $PV \neq CAHI$ adjust the OFTH to make $PV=CAHI$.

As shown below, the two points OFTL and OFTH construct a straight line. For accuracy, it is best to calibrate with the two points as far apart as possible. After the user calibration is complete, the input type will be stored in the memory. If the input type is changed, a calibration error will occur and an error code **CAEr** is displayed.

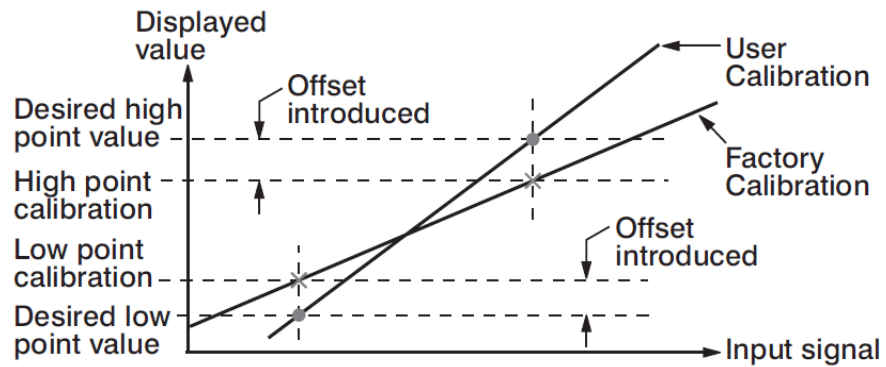

3-6 Two Point User Calibration

3.9 Digital Filter

In certain applications, the process value is too unstable to be read. To improve this, a programmable low pass filter incorporated in the limit controller can be used. This is a first-order filter with a time constant specified by the FILT parameter. A value of 0.5 seconds is used as a factory default. Adjust FILT to change the time constant from 0 to 60 seconds. 0 seconds represents no filter applied to the input signal. The filter is characterized by the following diagram.

Note

The Filter is available only for the process value (PV) and is performed for the displayed value only. The limit controller is designed to use an unfiltered signal for control even when a filter is applied. If a lagged (filtered) signal is used for control; it may produce an unstable process.

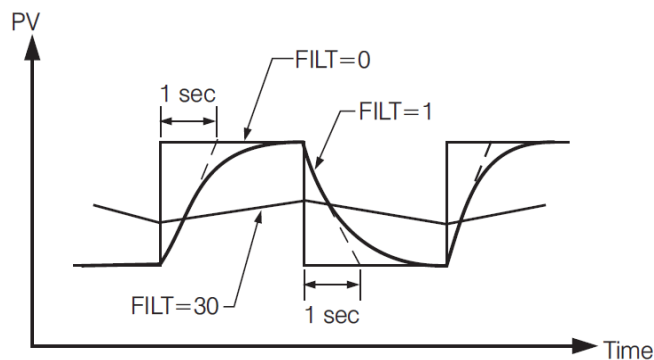

3-7 Filter Characteristics

3.10 Limit Annunciator

If L_AN (Limit annunciator) is selected for OUT2, the output 2 will act as a Limit Annunciator. If the limit is or has been reached and the RESET key (or remote reset contacts) has not been pressed since the limit was reached, then the limit annunciator output will be energized and the OUT2 indicator will be lit and remain unchanged until the RESET key or remote reset input is applied.

3.11 Remote Reset

If RRST is selected for E1FN or E2FN, the event input terminals will act as remote reset input. Pressing remote reset button will perform the same function as pressing the RESET key. Refer to [section 1.4](#) for RESET key function.

3.12 Remote Lock

If LOCK is selected for E1FN or E2FN, the event input terminals will act as remote lock input. Turning the remote lock switch on will keep all the parameter setting from been changed. If the switch is opened the lock indicator is extinguished and the up/down key is enabled. Depends on the user security configuration, the parameters can be changed.

Note:

- ❖ The user needs to observe CODE, PASS logic for the remote lock operation. In addition, if remote is needed, it means the remote priority is higher than local. Local changes will be over-written by remote operations. If the code is equal to "0", the remote LOCK feature won't work

3.13 Power Up Logic

Configurable power-up logic allows the user to select the latching output relay to require "RESET" or to provide normal or to provide normal latch operation at power-up. If power to the limit controller fails and power is reapplied, the controller goes through power up tests then starts in one of the following configurable conditions configured in PWRU parameter.

0. NoRM (Normal): After power down, the controller will operate normally in the same mode as before power was removed unless a limit has been exceeded after power up.

1. RST (Reset): After power down, the controller latching relay will have to be reset using the "Reset" key or digital(event) input option. The unit must be reset even if the device was not in a limit condition before power down. It must also be reset even if the device is not in a limit condition after power up.

Note: As the user needs to reset the unit by using reset key or digital(event) input, the annunciator output will not be activated at the power on stage at Reset Mode.

2. NoRL (Normal Latch): After power down, the controller will operate normally in the same mode as before power was removed unless a limit has been exceeded upon power up. If the limit was latched at power down, the unit will be in "Limit" at power up and have to be reset.

3.14 Reference Data

There are three reference data contained in setup menu. The reference data are read only data. The maximum historical PV, displayed by PV.HI, which shows the maximum process value since the last UNLOCK operation. The minimum historical PV, displayed by PV.LO, which shows the minimum process value since the last UNLOCK operation. The abnormal time, displayed by T.ABN, which shows the total accumulated time (minutes) during the process has been in abnormal condition since the last UNLOCK operation.

The values of reference data will be initiated as soon as the RESET key is pressed for 4 seconds (UNLOCK operation). After UNLOCK operation, the PV.HI and PV.LO values will start from the current process value and T.ABN value will start from zero.

3.15 Failure Transfer

The limit controller will enter failure mode if one of the following conditions occurs.

1. An SBER error occurs due to an input sensor break, an input current below 1mA for 4-20mA, or an input voltage below 0.25V for 1-5 V.
2. An ADER error occurs due to the A-D converter of the limit controller fails.

Output 1 will perform the failure transfer function as the limit controller enters failure mode.

3.15.1 Output 1 Failure Transfer

If Output 1 Failure Transfer is activated, it will perform like the limit controller is in abnormal condition.

3.15.2 Alarm Failure Transfer

An alarm failure transfer is activated as the limit controller enters failure mode. After that, the alarm output will transfer to the ON or OFF state which is determined by the set value of A1FT, A2FT and A3FT.

3.16 Data Communication

The limit controllers support RS-485 Modbus RTU protocol for data communication. Using a PC for data communication is the most economical way. The signal is transmitted and received through the PC communication Port. Since a standard PC can't support an RS-485 port, a network adaptor such as an RS232 to RS485 Converter or USB to Serial Converter must be used to convert RS-485 to RS-232 or USB for a PC. Many RS-485 units (up to 247 units) can be connected to one RS-232 port or USB Port. Therefore, a PC with 4 comm. ports can communicate with up to 988 units. It is quite economical.

3.16.1 RS-485 Setup

- ❖ Enters the setup menu.
- ❖ Set individual addresses for units connected to the same port.
- ❖ Set the Baud Rate (BAUD), Data Bit (DATA), Parity Bit (PARI) and Stop Bit (STOP) such that these values are accordant with PC setup conditions.

3.17 Retransmission

The limit controller can output (retransmit) PV or HSP or LSP via its retransmission terminals RE+ and RE- provided that the retransmission option is ordered. A correct signal type should be selected for the option board to meet the retransmission option installed. RELO and REHI are adjusted to specify the low scale and high scale values of retransmission.

3.18 Event Input

There are maximum of two Event Inputs available in this series of limit controllers. Refer [section 2.9](#) for wiring an event input. The Event input accepts a digital (on/off) type signal.

Types of signals that can be used to switch the event input as below.

- ❖ Relay
- ❖ Switch contacts
- ❖ Open collector Pull Low
- ❖ TTL logic level

One of the below functions can be chosen by using **EIFN1** and **EIFN2** contained in the setup menu. The same function cannot be set to more than one event input.

Note:

The limit controller must have the respective event input on the limit controller hardware to select any of the below event input function other than NoNE in E1FN or E2FN. Otherwise the limit controller may malfunction.

3.18.1 Event Input Functions

- ❖ **NoNE:** none
- ❖ **LOCK:** Remote Lock. If LOCK is selected for E1FN or E2FN, the event input terminals will act as remote lock input. Turning the remote lock switch on will keep all the parameter setting from been changed depends on the user security configuration. If the switch is opened the lock indicator is extinguished and the up/down key is enabled
- ❖ **RRST:** Remote Reset for Output1. If RRST is selected for E1FN or E2FN, the event input terminals will act as remote reset input. Pressing remote reset button will perform the same function as pressing the RESET key.
- ❖ **HSP2:** HSP2 activated to replace HSP1
- ❖ **LSP2:** LSP2 activated to replace LSP1
- ❖ **HLS2:** HSP2 & LSP2 activated to replace HSP1 & LSP1
- ❖ **HSP3:** HSP3 activated to replace HSP1
- ❖ **LSP3:** LSP3 activated to replace LSP1
- ❖ **HLS3:** HSP3 & LSP3 activated to replace HSP1 & LSP1
- ❖ **RS. A1:** Reset Alarm 1 as the event input is activated. However, if the alarm condition still exists, the alarm will remain on even though the event input is triggered.
- ❖ **RS. A2:** Reset Alarm 2 as the event input is activated. However, if the alarm condition still exists, the alarm will remain on even though the event input is triggered.
- ❖ **RS. A3:** Reset Alarm 3 as the event input is activated. However, if the alarm condition still exists, the alarm will remain on even though the event input is triggered.
- ❖ **RS.AO:** Reset all Alarms as the event input is activated. However, if the alarm condition still exists, the alarm will remain on even though the event input is triggered.
- ❖ **CA. LH:** Cancel the latched alarm as the event input is activated. However, if the alarm condition still exists, the alarm will remain on even though the event input is triggered.
- ❖ **R.REF:** Reset Reference Data PV. HI, PV. LO and T. ABN.

4 Applications

4.1 Limit Controller Application Wiring

Incorrect Wiring

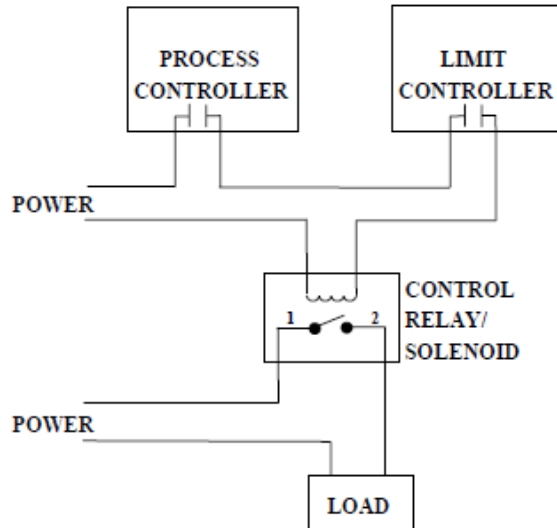

The Limit Controller CANNOT protect against a failure of the Control relay

Correct Wiring

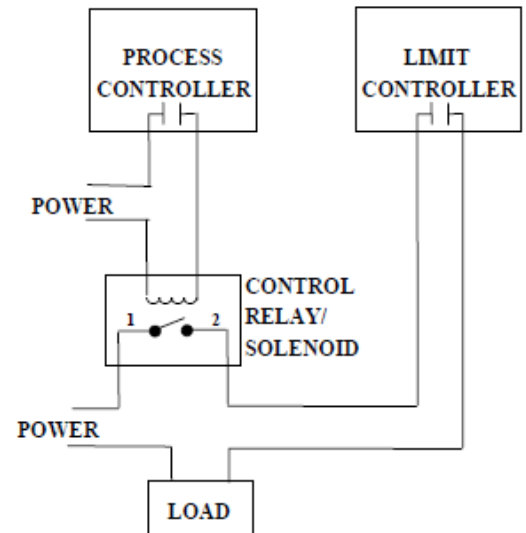

The Limit Controller CAN protect against a failure of the Control relay

4-1 Limit Controller Application Wiring

4.2 High Temperature Protection with Remote Reset

An oven uses a single-phase heater to heat the process. A single loop temperature control ZEL-C62 is used to regulate the temperature. A limit control ZEL-L62 is used to protect the process from being over heated. The wiring diagram is shown below.

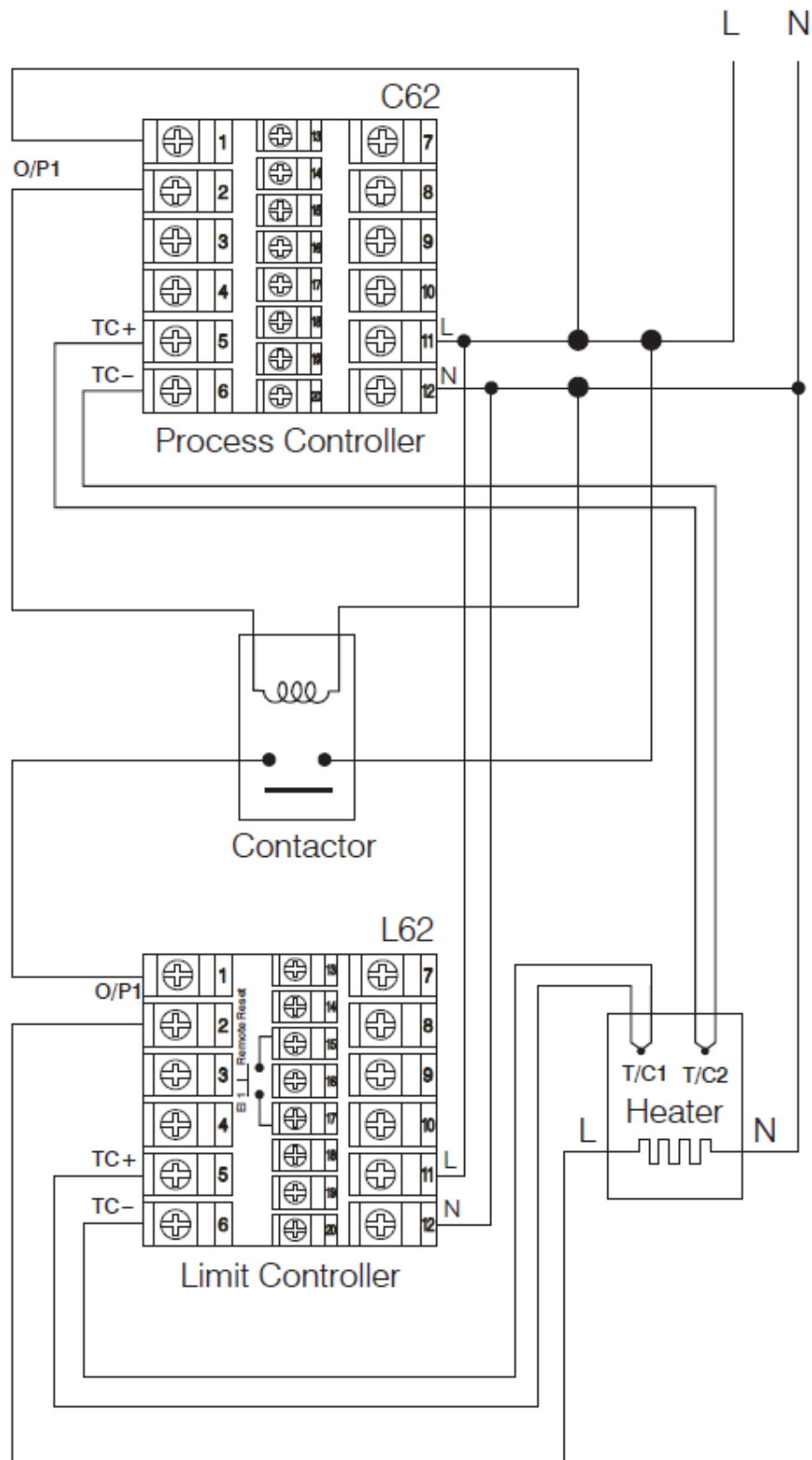

4-2 High Temperature Protection with Remote Reset

5 Calibration

 Do not proceed through this section unless there is a definite need to re-calibrate the limit controller. All previous calibration data will be lost. Do not attempt recalibration unless you have appropriate calibration equipment. If calibration data is lost, you will need to return the limit controller to your supplier who may charge you a service fee to re-calibrate the limit controller.



 Entering the calibration mode will break the limit control loop. Make sure that the system is allowable to apply the calibration mode.

5.1 Equipment Required Before Calibration



1. A high accuracy calibrator (Fluke 5520A Calibrator recommended) with the following functions
 - ❖ 0 - 100 mV millivolt source with 0.005 % accuracy
 - ❖ 0 - 10 V voltage source with 0.005 % accuracy
 - ❖ 0 - 20 mA current source with 0.005 % accuracy
 - ❖ 0 - 300Ω resistant source with 0.005 % accuracy
2. A test chamber providing 25°C - 50°C temperature range
3. A switching network (SWU16K, optional for automatic calibration)
4. A calibration fixture equipped with programming units (optional for automatic calibration)
5. A PC installed with calibration software (optional for automatic calibration)

The calibration procedures described in the following section are step by step manual procedures. Since a limit controller needs 30 minutes to warm up before calibration, calibrating the units one by one is quite inefficient. An automatic calibration system for small quantity as well as for an unlimited quantity is available upon request.



5.1.1 Manual Calibration Procedure

Set the Lock parameter to the unlocked condition (CODE= 0). Press and hold the scroll key until  appears on the display, then release the scroll key. Press the scroll key for 2-3 seconds then release, the display will show  and the unit will enter the calibration mode.

5.1.1.1 Calibrate Zero of A to D Converter

Short the thermocouple input terminals (TC+, TC-) and select the input type as K type Thermocouple in the INPT parameter in bASE menu configuration. Press and hold the scroll key until  appears on the display, then release the scroll key. Press the scroll key for 2-3 seconds then release, the display will show  and the unit will enter the calibration mode. Then press scroll key for at least 5 seconds. The display will blink a moment and a new value is obtained. If the display didn't blink or the obtained value is equal to -199.9 or 199.9, then the calibration failed.

5.1.1.2 Calibrate Gain of A to D Converter

Select the input type as K type Thermocouple in the INPT parameter in bASE menu configuration. Press and hold the scroll key until  appears on the display, then release the scroll key. Press the scroll key for 2-3 seconds then release, the display will show  and the unit will enter the calibration mode. Press scroll key to navigate to . Send a 60-mV signal to the thermocouple input terminals with the correct polarity. Press scroll key for at least 5 seconds. The display will blink a moment and a new value is obtained. If the display didn't blink or the obtained value is equal to -199.9 or 199.9, then the calibration fails.

5.1.1.3 Calibrate Offset of Cold Junction Compensation

Setup the equipment according to the following diagram for calibrating the cold junction compensation. Note that a K type thermocouple must be used.

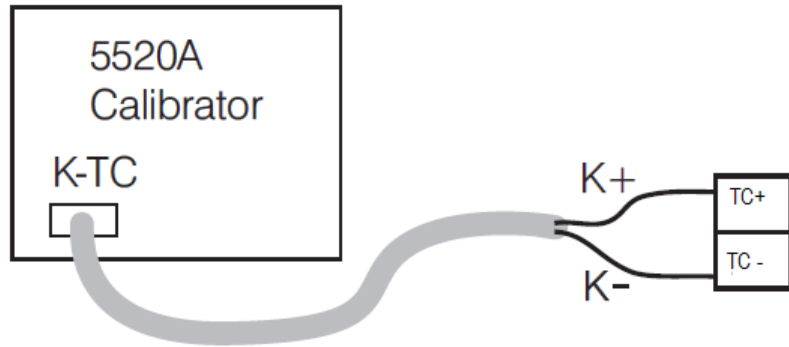

5-1 Cold Junction calibration Setup

Let limit controller sit at least 20 minutes in a room temperature of $25\pm 3^{\circ}\text{C}$. The 5520A calibrator is to be configured as a K type thermocouple output with internal compensation. Send a 0.00°C signal to the limit controller.

Select the input type as K type Thermocouple in the INPT parameter in bASE menu configuration. Press and hold the scroll key until $\boxed{\text{RL}}$ appears on the display, then release the scroll key. Press the scroll key for 2-3 seconds then release, the display will show $\boxed{\text{AdLo}}$ and the unit will enter the calibration mode. Press scroll key to navigate to $\boxed{\text{JLo}}$. Press up/down key to obtain 40.00. Press the scroll key for at least 5 seconds. The display will blink a moment and a new value is obtained. If the display didn't blink or the obtained value is equal to 5.00 or 40.00, then the calibration failed.

5.1.1.4 Calibrate Gain of Cold Junction Compensation

Setup the equipment the same as during [Offset calibration of Cold Junction Compensation](#). The unit under calibration is to be powered in a room with a temperature of $50\pm 3^{\circ}\text{C}$ for at least 20 minutes. The calibrator source is to be set to 0.00°C with internal compensation mode.

Select the input type as K type Thermocouple in the INPT parameter in bASE menu configuration. Press and hold the scroll key until $\boxed{\text{RL}}$ appears on the display, then release the scroll key. Press the scroll key for 2-3 seconds then release, the display will show $\boxed{\text{AdLo}}$ and the unit will enter the calibration mode. Press scroll key to navigate to $\boxed{\text{JH}}$. Press the scroll key for at least 5 seconds. The display will blink a moment and a new value is obtained. If the display didn't blink or the obtained value is equal to -199.9 or 199.9, then the calibration failed.

This setup is performed in a high-temperature chamber; hence it is recommended to use a computer to perform the procedures

5.1.1.5 Calibrate RTD Input

Select the input type as PT100 RTD in the INPT parameter in bASE menu configuration. Press and hold the scroll key until $\boxed{\text{RL}}$ appears on the display, then release the scroll key. Press the scroll key for 2-3 seconds then release, the display will show $\boxed{\text{AdLo}}$ and the unit will enter the calibration mode. Press scroll key to navigate to $\boxed{\text{EdL}}$. Send a $100\ \Omega$ signal to the RTD input terminals (PTA, PTB, PTB) according to the connection. Press the scroll key for at least 5 seconds. The display will blink a moment, otherwise, the calibration failed.

Press scroll key and the display will navigate to $\boxed{\text{EdH}}$. Change the resistance value to $300\ \Omega$. Press scroll key for at least 5 seconds. The display will blink a moment and two values are obtained for RTDH and RTDL. If the display didn't blink or the obtained value is equal to -199.9 or 199.9, then the calibration failed.

5.1.1.6 Calibrate Linear Input

Select the input type as 0 to 10V in the INPT parameter in bASE menu configuration. Press and hold the scroll key until **[RL]** appears on the display, then release the scroll key. Press the scroll key for 2-3 seconds then release, the display will show **[RdLo]** and the unit will enter the calibration mode. Press scroll key to navigate V1L. Send a 0V signal to the V+ and V- terminals. Press scroll key for at least 5 seconds. The display will blink a moment and a new value is obtained. If the display did not blink or the obtained value is equal to -199.9 or 199.9, the calibration failed.

Press scroll key and the display will navigate to V1G. Send a 10V signal to the V+ and V- terminals. Press scroll key for at least 5 seconds. The display will blink a moment and a new value is obtained. If the display did not blink or the obtained value is equal to -199.9 or 199.9, the calibration failed.

Select the input type as 0 to 20mA in the INPT parameter in bASE menu configuration. Press and hold the scroll key until **[RL]** appears on the display, then release the scroll key. Press the scroll key for 2-3 seconds then release, the display will show **[RdLo]** and the unit will enter the calibration mode. Press scroll key to navigate to MA1L. Send a 0mA signal to the mA+ and mA- terminals. Press scroll key for at least 5 seconds. The display will blink a moment and a new value is obtained. If the display did not blink or the obtained value is equal to -199.9 or 199.9, the calibration failed.

Press scroll key and the display will navigate to MA1G. Send a 20mA signal to the mA+ and mA- terminals. Press scroll key for at least 5 seconds. The display will blink a moment and a new value is obtained. If the display did not blink or the obtained value is equal to -199.9 or 199.9, the calibration failed.

6 Communication

This chapter explains the Modbus Communication protocol of the limit controller using RS-485 communication. This supports only RTU mode. Data is transmitted as 8-bit binary bytes with 1 start bit, 1 stop bit and optional parity checking (None, Odd, Even). Baud rate may be set to 2400, 4800, 9600, 14400, 19200, 28800, 38400, 57600 and 115200 BPS.

6.1 Functions Supported

Only function code 03, 06 and 16 are available for this series of limit controllers. The message formats for each function code are described as follows.

6.1.1 Function Code 03: Read Holding Registers

Query (From Master)	Slave Address (1~247)	Response (From Slave)	Slave Address (1~247)
	Function Code (03)		Function Code (03)
	Starting Address of Register Hi (00)		Byte Count
	Starting Address of Register Lo (00~49, 51~88, 128~132, 139, 140, 142, 143)		Data1 Hi
	No of Words Hi (00)		Data1 Lo
	No of Words Lo (1~81)		Data2 Hi
	CRC16 Hi		Data2 Lo
	CRC16 Lo		...
			Data 'n' Hi
			Data 'n' Lo
	CRC16 Hi		
	CRC16 Lo		

6-1 Function Code 03

6.1.2 Function Code 06: Pre-set Single Register

Query (From Master)	Slave Address (1~247)	Response (From Slave)	Slave Address (1~247)
	Function Code (06)		Function Code (06)
	Starting Address of Register Hi (00)		Starting Address of Register Hi (00)
	Starting Address of Register Lo (00~49,51~88,128~132,139,140,142,143)		Starting Address of Register Lo (00~49,51~88,128~132,139,140,142,143)
	Data Hi		Data Hi
	Data Lo		Data Lo
	CRC16 Hi		CRC16 Hi
	CRC16 Lo		CRC16 Lo

6-2 Function Code 06

6.1.3 Function Code 16: Pre-set Multiple Register

Query (From Master)	Slave Address (1~247)	Response (From Slave)	Slave Address (1~247)
	Function Code (16)		Function Code (16)
	Starting Address of Register Hi (00)		Starting Address of Register Hi (00)
	Starting Address of Register Lo (00~49,51~88,128~132,139,140,142,143)		Starting Address of Register Lo (00~49,51~88,128~132,139,140,142,143)
	No of Words Hi (00)		No of Words Hi (00)
	No of words Lo (1~81)		No of words Lo (1~81)
	Bytes Count (2~162)		Bytes Count (2~162)
	Data1 Hi		Data1 Hi
	Data1 Lo		Data1 Lo
	Data2 Hi		Data2 Hi
	Data2 Lo		Data2 Lo

	Data 'n' Hi		Data 'n' Hi
	Data 'n' Lo		Data 'n' Lo
	CRC16 Hi		CRC16 Hi
CRC16 Lo	CRC16 Lo		

6-3 Function Code 16

6.2 Exception Responses

If the limit controller receives a message which contains a corrupted character (parity check error, framing error etc.), or if the CRC16 check fails, the limit controller ignores the message. However, if the limit controller receives a syntactically correct message which contains an illegal value, it will send an exception response, consisting of five bytes as follows:

Slave address +offset function code + exception code + CRC16 Hi +CRC16 Lo

Where the offset function code is obtained by adding the function code with 128 (i.e. function 3 becomes H'83), and the exception code is equal to the value contained in the following table.

Exception Code	Description	Reason
1	Bad Function Code	The function code is not supported by the limit controller
2	Illegal Data Addresses	Register address out of range
3	Illegal Data Value	Data value out of range or attempt to write a read-only or protected data

6-4 Exception Code

6.3 Parameter Mapping

The parameter mapping of Modbus address is available in section 1.9

6.4 Error Code

The description of the Error code is explained below

Error Code	Display Symbol	Description & Reason	Corrective Action
10	ER10	Communication error: bad function code	Correct the communication software to meet the protocol requirements.
11	ER11	Communication error: register address out of range	Do not issue an over-range address of the register to the slave
14	ER14	Communication error: attempt to write a read-only data	Do not write read-only data or protected data to the slave.
15	ER15	Communication error: write a value which is out of range to a register	Do not write an over-range data to the slave register
16	EIER	Event Input Error: Two or more event inputs are set to the same function	Do not set the same function in two Event Input Function parameters (E1FN and E2FN)
29	EEPR	EEPROM can't be written correctly	Return to factory for repair.
30	CJER	Cold junction compensation for Thermocouple malfunction	Return to factory for repair.
39	SBER	Input sensor break, or input current below 1 mA if 4-20 mA is used, or input voltage below 0.25V if 1 - 5V is used	Replace the input sensor.
40	ADER	A to D converter or related component(s) malfunction	Return to factory for repair.

6-5 Error Code

6.5 Mode

The Value of the Mode Register is as below.

Value	H'000X	H'010X	H'040X	H'0X00	H'0x01
Mode	Normal mode	Calibration mode	Failure mode	Alarm status is off	Alarm status is on

6-6 Operation Mode

Bit wise description of Mode register value as below.

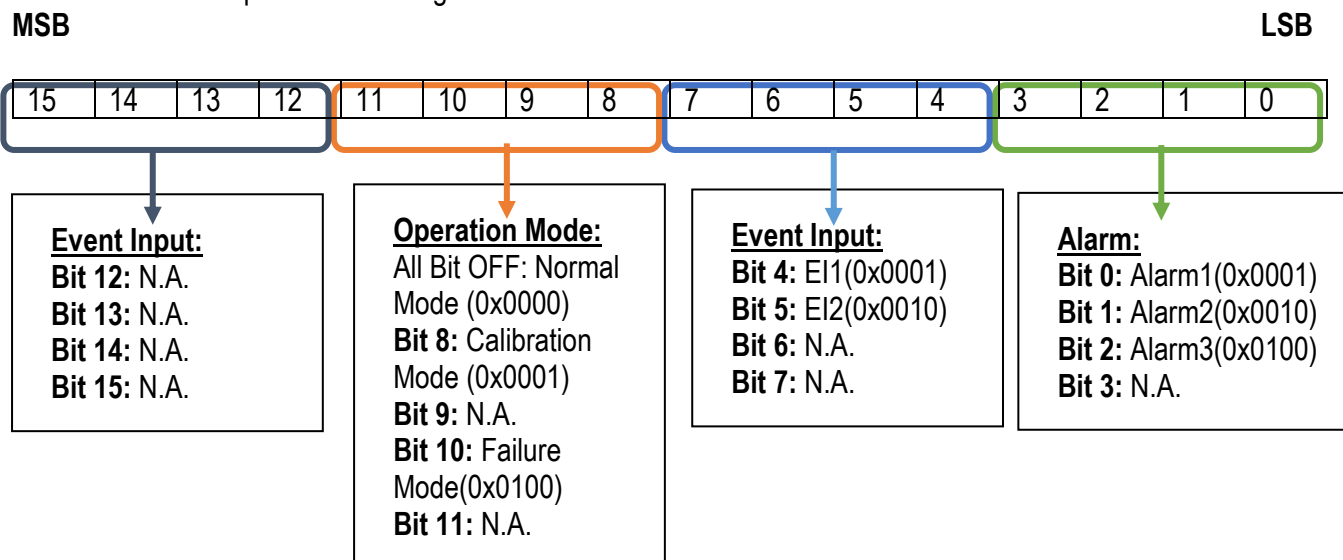

6.6 PROG Code

The Program Code is defined in the below table.

Program Code	Model No
26.XX	L22
64.XX	L62
45.XX	L42

6-7 Program Code

6.7 Scaling

The values stored in registers are based on 2's complement format. The relation between the value of number in register and its actual value is shown as following table.

Data in Register	65535	65534	50000	32769	32768	32767	10000	1000
Actual Value	-1	-2	-15536	-32767	-32768	32767	10000	1000

6-8 Data Conversion

6.8 Communication Examples

6.8.1 Read PV

Send the following command to the limit controller via the communication port

	03	00	H'40	00	01	HI	LO
Slave Address	Function Code	Starting Address	No of Words	CRC16			

6.8.2 Perform Reset Function (same effect as pressing R key)

Query

	06	00	H'48	H'68	H'25	HI	LO
Slave Address	Function Code	Register Address	Data Hi /Lo	CRC16			

6.8.3 Read All Parameters

Query

	03	00	00	00	H'50	HI	LO
Slave Address	Function Code	Starting Address		No of Words		CRC16	

6.8.4 Calibrate ADLO

	H'10	00	H'48	00	02	04	H'68	H'29	00	H'33	HI	LO
Slave Address	Function Code	Register Address		No of Words		Bytes Count	Data Hi /Lo		Data Hi /Lo		CRC16	

6.8.5 Command Mode

The command and job1 register values are as below for different modes.

Command Mode Value		Command Mode	Description	Job1 Value			Function Code	
Dec	Hex			Dec	Hex	06	16	
26668	682C	Unlock.	Temporarily unlocked. CMND will hold the "PASLOCK" value of 26668(0x682C) until other CMND value is set or 180 seconds.	✓	✓
26665	6829	Calibration Mode	Calibrate ADLO	ADLO	51	0033		✓
			Calibrate ADHI	ADHI	52	0034		✓
			Calibrate RTDL	RTDL	53	0035		✓
			Calibrate RTDH	RTDH	54	0036		✓
			Calibrate CJLO	CJLO	55	0037		✓
			Calibrate CJHI	CJHI	56	0038		✓
			Calibrate V1L	V1L	57	0039		✓
			Calibrate V1G	V1G	58	003A		✓
			Calibrate MA1L	MA1L	59	003B		✓
26661	6825	Reset	Do same action as Reset Key	✓	✓

6-9 Command Register



ZESTA ENGINEERING LTD.

212 Watline Avenue
Mississauga, ON L4Z 1P4
Canada

(905) 568-3100

www.zesta.com