

CAST-X 1000 Circulation Heater

With optional built-in controls, CAST-X 1000 is a straightforward solution, perfect for OEMs and end users.



Designed and manufactured by Cast Aluminum Solutions (CAS), CAST-X Circulation Heaters are engineered using the latest thermal modeling and finite element analysis technology. CAST-X heaters feature low-watt-density heating elements cast into aluminum bodies which also contain the helical-coiled stainless steel flowpath tubes.

The media is sequestered in these tubes, never touching the heating elements: a critical safety benefit, especially when heating explosive or sensitive media. All CAST-X units are capable of heating liquids and gases alike.

CAST-X heaters are self-draining, for safety and cleanliness. With compact, non-welded bodies, plus NEMA & ATEX enclosures, CAST-X units are small-footprint, high-output heaters that meet the needs of high-purity processes, flammable operations, and your most critical heating applications.

APPLICATIONS:

- Engine Pre-Heating
- Solvent Heating
- Hydrogen Peroxide Vaporization
- Commercial Foodservice Machines
- Air, Co₂ and Nitrogen Heating
- Coating & Resin Heating
- Steam Generation



SPECIFICATIONS:

- Power:
 - 700 W Total to 3 kW Total
 - Voltage Range: 120 - 480 V
 - Max Line Current: 15 A
- Tubing:
 - .313" OD (5/16") (7.9 mm)
 - .020" Wall (1.7 mm)
 - Overall Process Tube Length: 137" (3480 mm)
 - 316L Stainless Steel (standard)
 - Inconel (optional upgrade)
 - Passivated or Electro-Polished (optional upgrades)
- Max Pressure: 2100 psi (144 bar)
- Enclosures:
 - NEMA 1 (general-purpose/dust-proof)
 - NEMA 4 (moisture-resistant)
- Max Working Temperatures:
 - No Enclosure: 662°F (350°C)
 - NEMA 1 (dust-proof/general-purpose): 608°F (320°C) with thermostat: 250°F (121°C)
 - NEMA 4 (moisture-resistant): 482°F (250°C) with thermostat: 250°F (121°C)

Published temperatures are for housing at 12 o'clock position; higher temps may be possible at 6 o'clock position. See factory for details.

- Sensors:
 - K or J Type Thermocouples Standard
 - Snap-Action High-Limit Thermostat
 - Process and High-Limit Thermocouples
- Available Accessories:
 - Insulating Jacket
 - Compression Fittings

FEATURES & BENEFITS:

- SS 316L Fluid Path is Separate from Heating Elements (allows safe heating of sensitive materials and prevents contamination)
- Compact Footprint Saves Space in Equipment
- Self-Draining, Low-Maintenance Design
- Available With Thermostat, to Simplify Control Wiring
- Robust Cast-In Construction Insures Long Heater Life
- Minimal Leak Potential Due to Non-Welded Design
- Wide Application Compatibility (including high pressure)

CAST-X 1000 Circulation Heater

NO ENCLOSURE

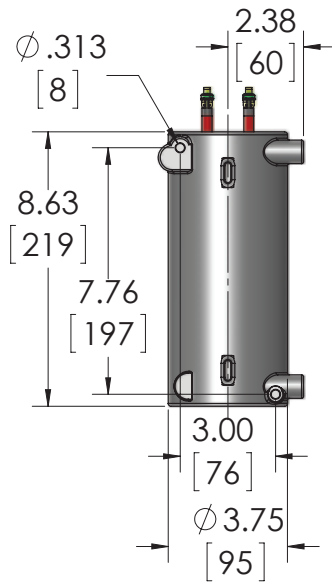

GENERAL-PURPOSE (NEMA 1) NO THERMOSTAT

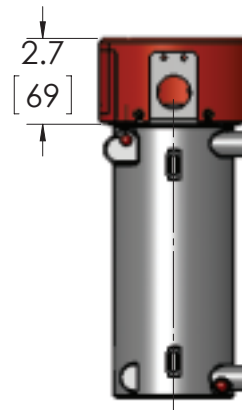

CAST-X 1000 Heating Profile: Delta-T Water

(Process Fluid = Water @ 42°F / 5.6°C Inlet Temp, Single Pass, 100% Power, Set Point 752°F / 400°C)

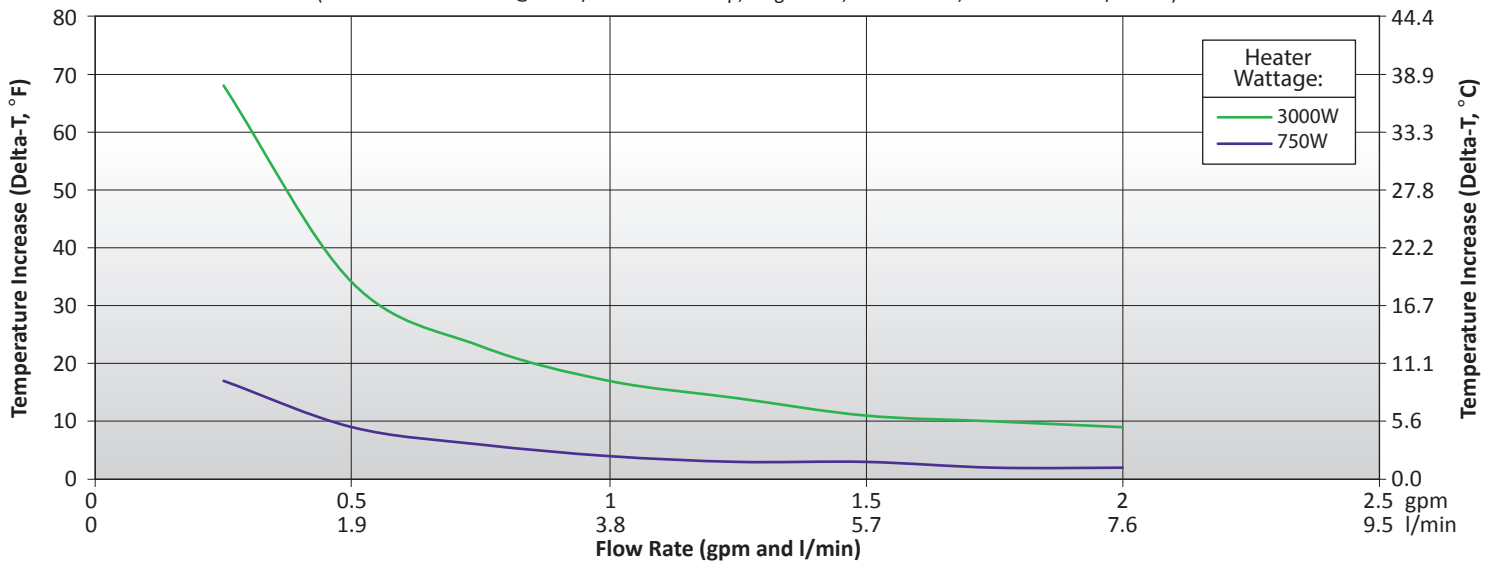

CAST-X 1000 Pressure Drop Profile: Delta-P Water

(Process Fluid = Water. Change in Pressure from Inlet to Outlet, Single Pass)

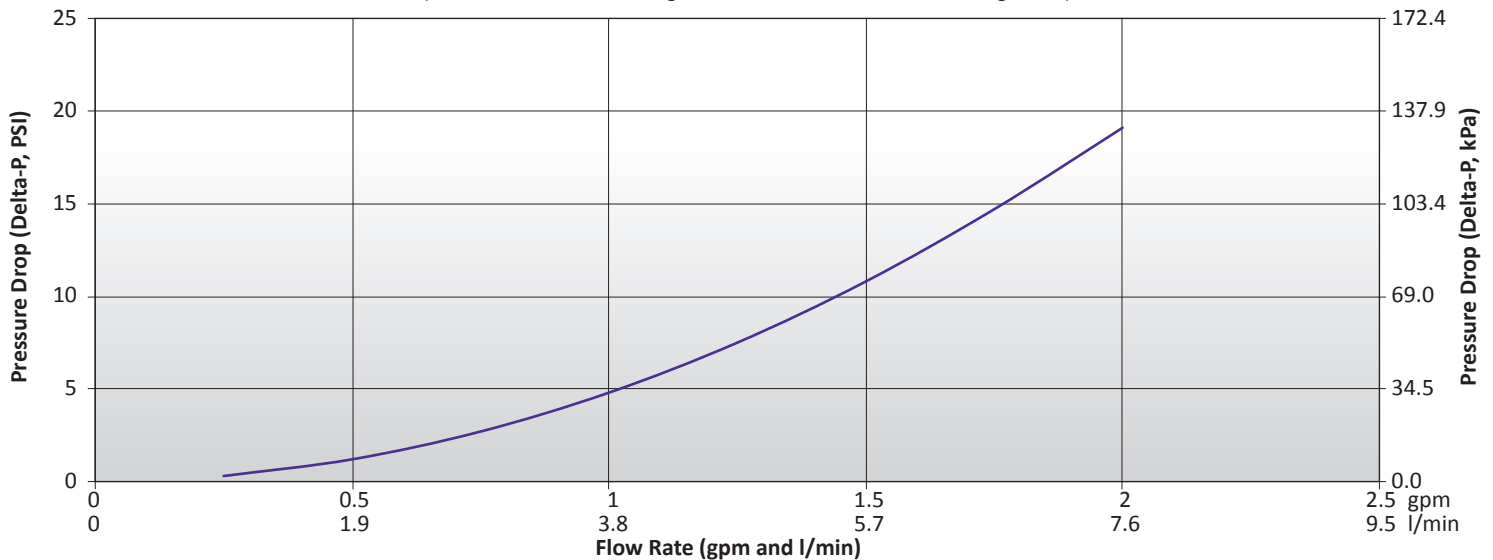

GENERAL-PURPOSE (NEMA 1) WITH THERMOSTAT

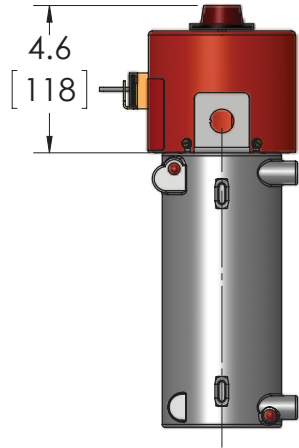

MOISTURE-RESISTANT (NEMA 4) WITH OR WITHOUT THERMOSTAT

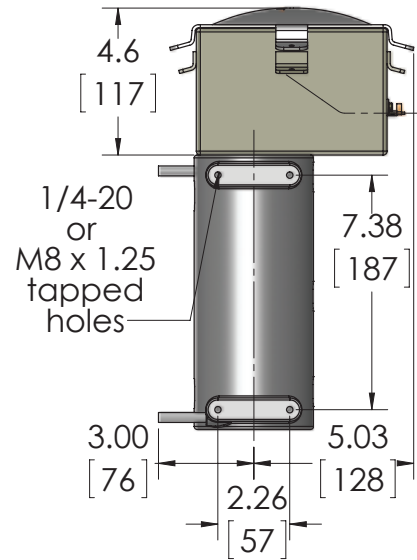

CAST-X 1000 Heating Profile: Delta-T Air

(Process Fluid = Air @ 100 psi (689 kPa), 70.7°F / 21.5°C, Single Pass, Set Point 752°F / 400°C)

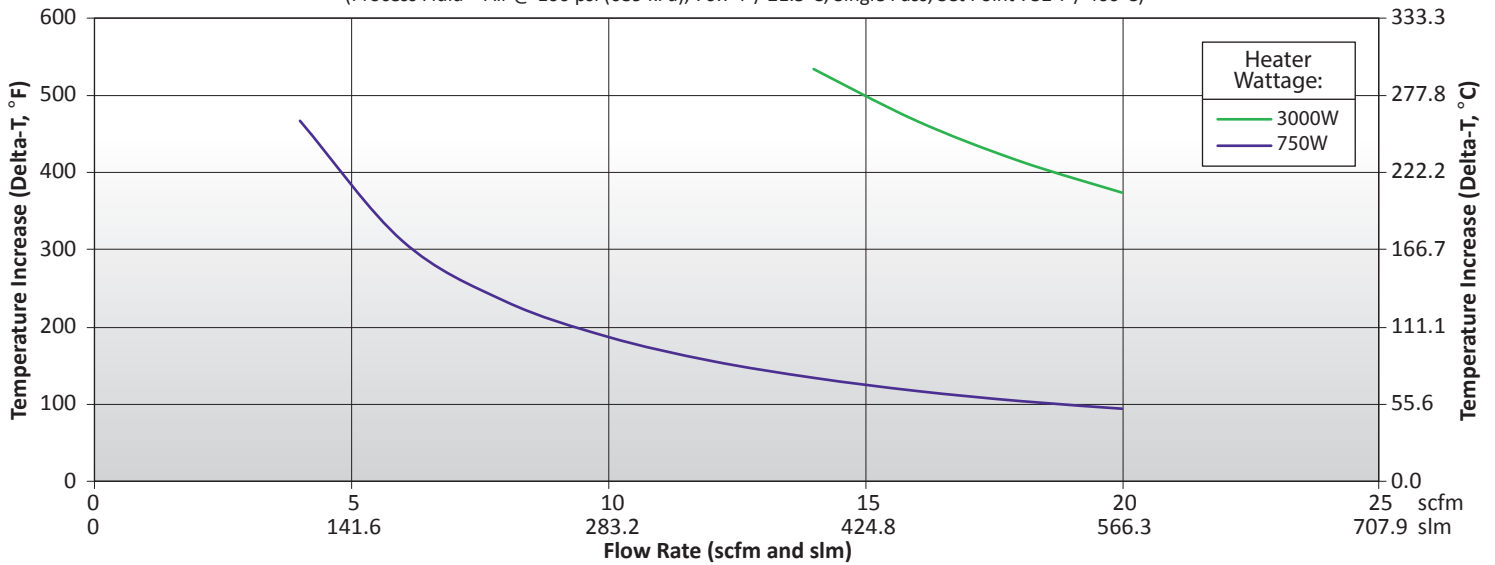

CAST-X 1000 Heating Profile: Delta-P Air

(Process Fluid = Air @ 100 psi (689 kPa), 70.7°F / 21.5°C, Single Pass, Set Point 752°F / 400°C)

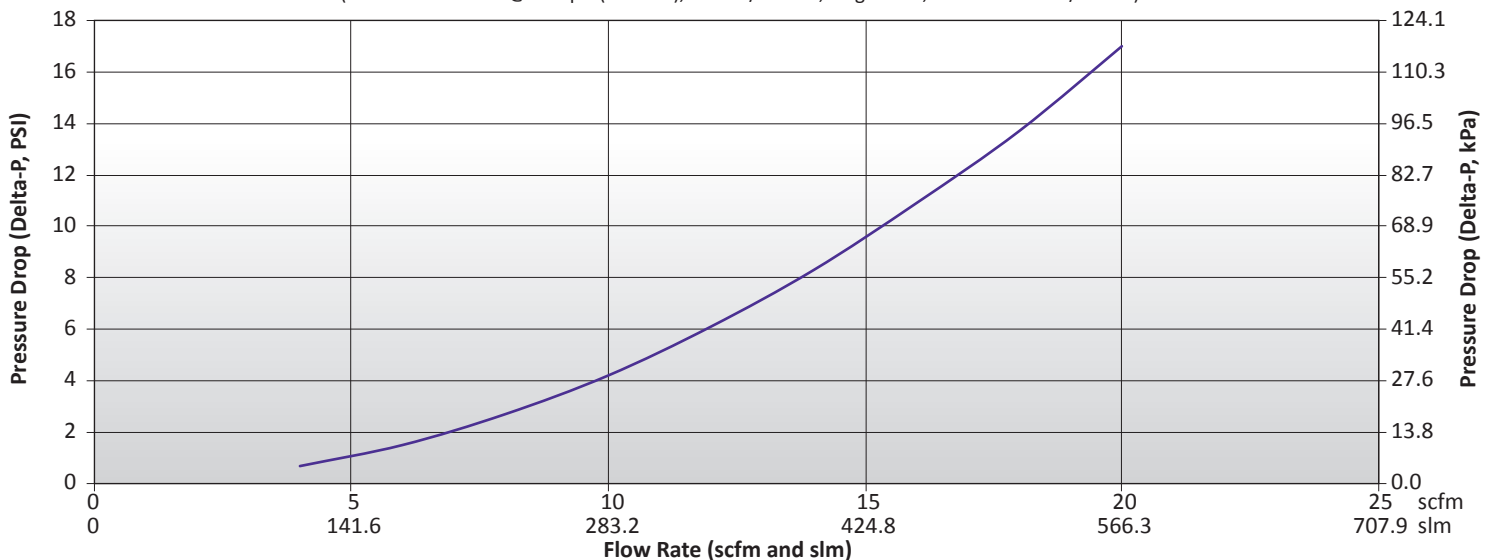

CAST-X 1000 Circulation Heater

Engineering Expertise • Speed to Market • Operational Excellence

Cast Aluminum Solutions (CAS) manufactures the CAST-X line of circulation heaters, plus a broad range of heating, cooling, and non-thermal components. We are relied upon by OEMs and end-users alike throughout the semiconductor, medical device, aerospace, industrial gas, fluid-handling, food equipment, and energy markets.

Our multi-discipline team of engineers and technicians works closely with customers to develop practical solutions to complex process challenges. We utilize industry standard applications such as Finite Element Analysis (FEA), SolidWorks® 3-D CAD technology, and a range of structural analysis & thermal modeling tools.

CAS is an ISO 9001 Certified company with a fully-equipped R&D facility. Testing capabilities include X-Ray, ultrasound, helium leak, and infra-red technology, plus the latest coordinate measuring machines (CMM). Our in-house casting facility utilizes a permanent mold low-pressure casting process which reliably produces low-porosity, high-quality aluminum products. We offer an array of precision CNC machining options, finishing options such as electroless nickel plating, Teflon® coatings, clear-coat and hard-coat anodizing, plus high-value-added testing and inspection services.

Headquartered in Batavia, Illinois (just outside Chicago) we serve customers worldwide.

See the below map to locate a Sales Engineer, or contact CAS directly. We look forward to working with you.

With offices worldwide, the CAS Team of knowledgeable and experienced representatives is ready to assist with your project.

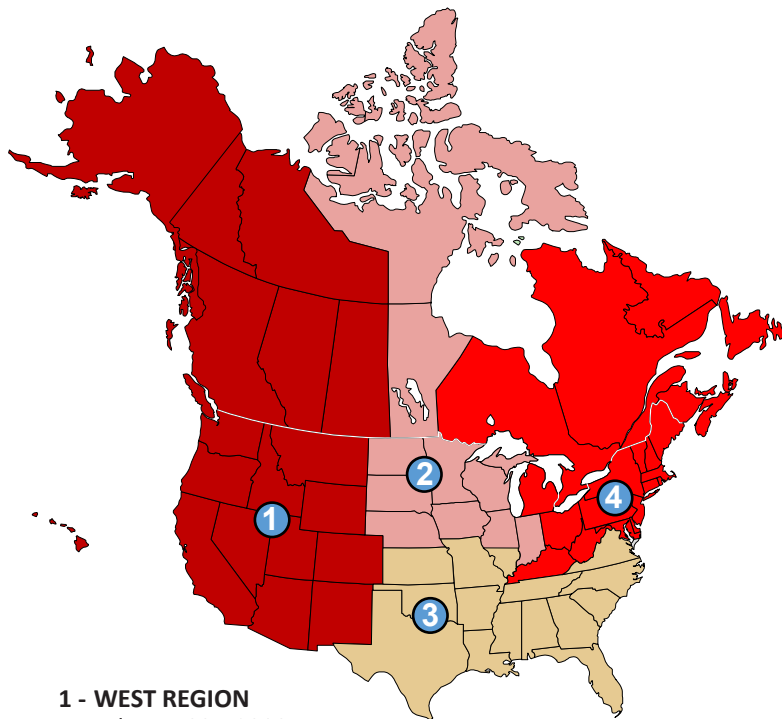

1 - WEST REGION
Tel: 714-935-2999

2 - MIDWEST REGION
Chicago Tel: 847-458-1500
Minneapolis Tel: 952-892-9222

3 - SOUTH REGION
Tel: 678-951-8120

4 - NORTHEAST REGION
Tel: 513-398-5500

ENERGY PROCESS DIVISION
Tel: 866-948-1708

SEMICONDUCTOR DIVISION
Tel: 408-754-3370

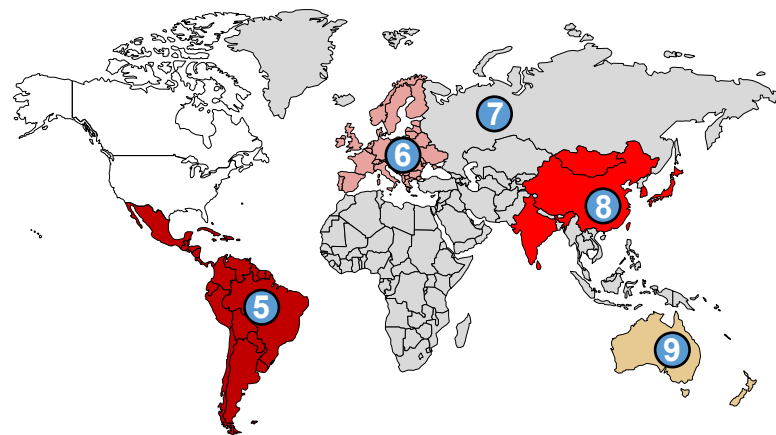

5 - MEXICO, CENTRAL and SOUTH AMERICA
Tel: +52 442-256-2200

6 - EUROPE
France
Tel: +33 (0) 1-41-32-79-70

Germany
Tel: +49 7253-9400-0

Italy
Tel: +39 02-458-8841

Spain
Tel: +34 91-675-1292

United Kingdom
Tel: +44 115-964-0777

7 - RUSSIA, AFRICA & MIDDLE-EAST
Tel: +1 630-879-2696

8 - ASIA
China
Tel: +86 21-3532-8532

Japan
Tel: +81 3-3518-6630

Korea
Tel: +82 2-2169-2600

Taiwan
Tel: +866 7-288-5168

India
Tel: +91 40-666-12700

9 - AUSTRALIA & NZ
Tel: +61 3-9335-6449

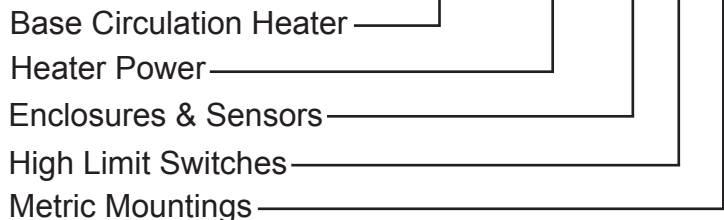

BX8L4M AAAA-BBCC-D**Building a CAST-X 1000 Part Number**

Use the graphs below to build your CAST-X 1000.
 Assigning numbers for sections AAAA, BB and CC.

If you need metric mountings, assign "M" to section D.
 If metric mounts are not required, leave section D blank.

For assistance, contact CAS directly.

VOLTAGE, POWER, CIRCUIT TYPE

Volts refers to line volts (V_L). Amps refers to line current (I_L).

Section "AAAA"	Volts (V)	Watts (W)	Circuit Type (all are single circuit)	Amps (A)
200A	240	3000	SINGLE PHASE	12.5
200D	240	750	SINGLE PHASE	3.1
200B	480	3000	SINGLE PHASE	6.3
200C	120	750	SINGLE PHASE	6.3

ENCLOSURES AND SENSORS

All thermocouples are ungrounded, for optimal performance

Section "BB"	Description	Thermocouple Qty.	Enclosure
00	NO SENSOR	0	NO ENCLOSURE
S2	30 TO 250°F (-1 TO 121°C) SINGLE POLE THERMOSTAT	1	NEMA 1
SJ	J-TYPE THERMOCOUPLE IN THERMOWELL	1	NEMA 1
SK	K-TYPE THERMOCOUPLE IN THERMOWELL	1	NEMA 1
W0	NO SENSOR	0	NEMA 4
W2	30 TO 250°F (-1 TO 121°C) SINGLE POLE THERMOSTAT	1	NEMA 4
WJ	J-TYPE THERMOCOUPLE IN THERMOWELL	1	NEMA 4
WK	K-TYPE THERMOCOUPLE IN THERMOWELL	1	NEMA 4

SNAP ACTION HIGH LIMITS SWITCHES

Pilot duty only

Section "CC"	Switch
00	NONE
01	MANUAL RESET, 260°F (127°C)

METRIC MOUNTING HOLES

Place an "M" in section D if metric mounting holes are required.

If standard Imperial mounting holes are desired, section D can be left blank

Section "D"	Metric Mounting Holes
M	M8 X 1.25 METRIC TAPPED MOUNTING HOLES

CUSTOM DESIGNS & COMPONENTS

CAS offers several options for special tubes, sensors, and finishes.

For these options, please call a CAS Representative for a quote.

Options	
INCONEL, MONEL OR HASTELLOY TUBES	RTDS (RESISTANCE TEMPERATURE DETECTORS)
ELECTRO-POLISHED OR PASSIVATED TUBES	SPECIAL HIGH-LIMIT SWITCHES
THICK WALL TUBES	NPT FITTINGS

ACCESSORIES

These PNs are totally separate from the PNs for the heater

Part Number	Component
274-55-6-4	COMPRESSION FITTINGS (HIGH PRESSURE) / PAIR (SHIPPED LOOSE)
307-0-2-1	INSULATION JACKET, MAXIMUM TEMPERATURE 400°F (204°C)
307-0-20-1	INSULATION JACKET, MAXIMUM TEMPERATURE 1112°F (600°C)

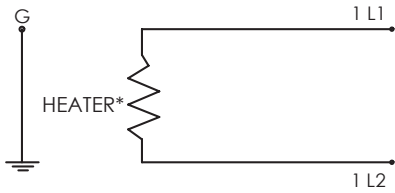

SINGLE PHASE CIRCUIT

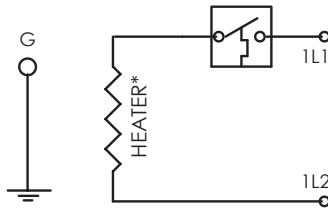

SINGLE PHASE CIRCUIT WITH SWITCH

CAST-X 1000 Available Circuit Types

The CAST-X 1000 is manufactured with a single heating element, and is offered with or without a thermostat.

Refer to I&M Manual for further details on wiring of snap-action switches and thermostats (if applicable).



NO ENCLOSURE OPTION



NEMA 1 ENCLOSURE WITH THERMOSTAT



NEMA 4 ENCLOSURE, WITH THERMOSTAT INSIDE ENCLOSURE

Need Help with Part Numbers or Engineering Calculations?

One of the key advantages of working with CAS is the accessibility of our team and ability to offer assistance. The CAS Team is ready and available to help you work through part number configurations, provide engineering advice, and ensure customers purchase the heater most appropriate for their particular application.

CAS Engineers are accustomed to working closely with customers to generate accurate calculations and models. We have a range of powerful tools at our disposal, including Finite Element Analysis (FEA) software, 3-D CAD applications, and infra-red thermal testing.

Our mission is developing solutions, from concept to reality. So feel free to contact the CAS Team directly:



Main Tel: 630-879-2696
 Toll-Free: 888-367-3992
 Sales@CastAluminumSolutions.com
 www.CastAluminumSolutions.com