



Series F4P

User's Manual



96mm x 96mm Process Controller (1/4 DIN) with Guided Setup and Programming



1241 Bundy Boulevard, Winona, Minnesota USA
Phone: +1 (507) 454-5300, Fax: +1 (507) 452-4507 <http://www.watlow.com>



ISO 9001



Registered Company
Winona, Minnesota USA

English

0600-0032-0013 Rev E



August 2011

Safety Information



**CAUTION or
WARNING**



**Electrical
Shock Hazard
CAUTION or
WARNING**

We use note, caution and warning symbols throughout this book to draw your attention to important operational and safety information.

A “NOTE” marks a short message to alert you to an important detail.

A “CAUTION” safety alert appears with information that is important for protecting your equipment and performance. Be especially careful to read and follow all cautions that apply to your application.

A “WARNING” safety alert appears with information that is important for protecting you, others and equipment from damage. Pay very close attention to all warnings that apply to your application.

The safety alert symbol,  (an exclamation point in a triangle) precedes a general CAUTION or WARNING statement.

The electrical hazard symbol,  (a lightning bolt in a triangle) precedes an electric shock hazard CAUTION or WARNING safety statement.

Technical Assistance

If you encounter a problem with your Watlow controller, review your configuration information to verify that your selections are consistent with your application: inputs; outputs; alarms; limits; etc. If the problem persists after checking the configuration of the controller, you can get technical assistance from your local Watlow representative (see back cover), or in the U.S., dial +1 (507) 494-5656 between 7 a.m. and 5 p.m., Central Standard Time (CST). Ask for for an Applications Engineer. Please have the following information available when calling:

- Complete model number
- All configuration information
- User’s Manual
- Diagnostic menu readings

Your Comments

We welcome your comments or suggestions on this user’s manual. Please send them to: Technical Writer, Watlow Winona, 1241 Bundy Blvd., P.O. Box 5580, Winona, Minnesota, USA 55987-5580; telephone: +1 (507) 454-5300; fax: +1 (507) 452-4507.

© Copyright 2003 by Watlow Winona, Inc. All rights reserved. (2328)

T

Series F4P: Table of Contents

Operating the Controller

Chapter 1: Introduction	1.1
Setup Steps	1.2
Chapter 2: Operating from the Front Panel	2.1
Keys, Displays and Lights	2.2
Guided Programming	2.3
Custom Main Page	2.3
Auto and Manual Operation	2.3
Troubleshooting, Alarms and Errors	2.4

Programming the Controller

Chapter 3: Operations Page	3.1
Alarm Set Points	3.1
To Clear an Alarm or Error	3.1
Autotune PID	3.2
Edit PID	3.2
Multiple PID Sets	3.3
Cascade	3.3
Chapter 4: Setup Page	4.1
Parameter Setup Order	4.1
Customizing the Main Page	4.2
Static Messages	4.2
Chapter 5: Factory Page	5.1
Security	5.1
Diagnostics	5.3
Calibration	5.3

Chapter 6: Parameters	6.1
Pages, Menus and Parameters	6.1
Main Page	6.2
Operations Page Parameter Table	6.4
Setup Page Parameter Table	6.11
Factory Page Parameter Table	6.26
Chapter 7: Features	7.1
Inputs	7.2
Control Methods	7.5
Other Features	7.9
Alarms	7.10
Advanced Features	7.12
Features in Enhanced Series F4P Controller	7.15

Installation and Wiring

Chapter 8: Installation and Wiring	8.1
Wiring the F4P Controller	8.5

Communications

Chapter 9: Communications	9.1
Exception Responses	9.1
Modbus Registers (Alphabetical)	9.2
Modbus Registers (Numerical)	9.11

Appendix

Specifications	A.2
Ordering Information	A.3
Declaration of Conformity	A.4
Glossary	A.5
Index	A.8
Software Map	A.13
About Watlow and Warranty Information	Inside Back Cover

A downloadable electronic copy of this user manual is available free of charge through Watlow's web site: <http://www.watlow.com/literature/prodtechinfo>

Notes

1

Chapter One: Introduction

Watlow's Series F4P, 96mm by 96mm (1/4 DIN) Temperature/Process controllers are easy to set up, program and operate in the most demanding applications. The F4P Temperature/Process controller includes:

- four-line, high resolution LCD display;
- guided setup software;
- context-sensitive information key;
- 16-bit microprocessor;
- universal and digital inputs.

Inputs and Outputs

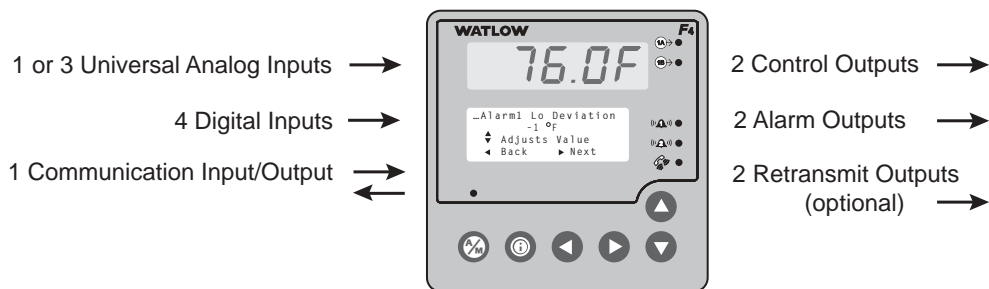

Figure 1.1 — Series F4P Inputs and Outputs (Standard, 1 input, F4P _ _ _ AA - _ _ _ _; and Enhanced, 3 inputs, F4P _ _ _ AB - _ _ _ _).

Setup Steps

Your Series F4P may arrive as an independent unit or already installed in other equipment. The steps below may or may not apply to all units. The Series F4P software can be locked with different types of security. See Chapter 5, Factory Page.

What to do

How to do it

-
- | | |
|---|--|
| 1 Install and wire the controller. | <i>See Chapter 8, Installation and Wiring. (This step will not be necessary if the Series F4P is already installed in equipment.)</i> |
| 2 Configure the controller to suit your application. | <i>Learn to navigate the software in Chapter 2, Operating from the Front Panel, and then go to Chapter 4, Setup Page. For background, you may also want to refer to Chapter 7, Features. (This step may not be necessary if the Series F4P is already installed in the equipment.)</i> |
| 3 Tune the system and set alarm set points. | <i>See Chapter 3, Operations Page.</i> |
| 4 Establish a set point for static set point control. | <i>See Chapter 3, Operations Page.</i> |
-

The **i** Key

During all these steps, the Information Key will summon helpful definitions and setup tips. Just position the cursor next to the item you want to know more about, then press the key. Press it again to return to your task.

2

Chapter Two: Navigation and Operating from the Front Panel

- Displays and Indicator Lights2.2
- Guided Programming2.3
- Custom Main Page2.3
- Auto and Manual Operation2.3
- Troubleshooting Alarms and Errors2.4

Series F4P software is organized into four sections called “pages.” The Main Page is the central, default page that displays status information on the lower display. To get to the other pages, you must begin in the Main Page.

✓ **Note:** Access to the software is limited while the controller is autotuning (Setup and Factory pages are not accessible).

The Main Page presents error messages, static messages and the status of inputs, outputs and depending on the Custom Main Page, parameter settings in the Setup Page.

Scroll to the bottom of the Main Page to reach the other pages.

When you exit the Setup or Factory Page, the controller prompts you to restore the old settings or save the new ones.

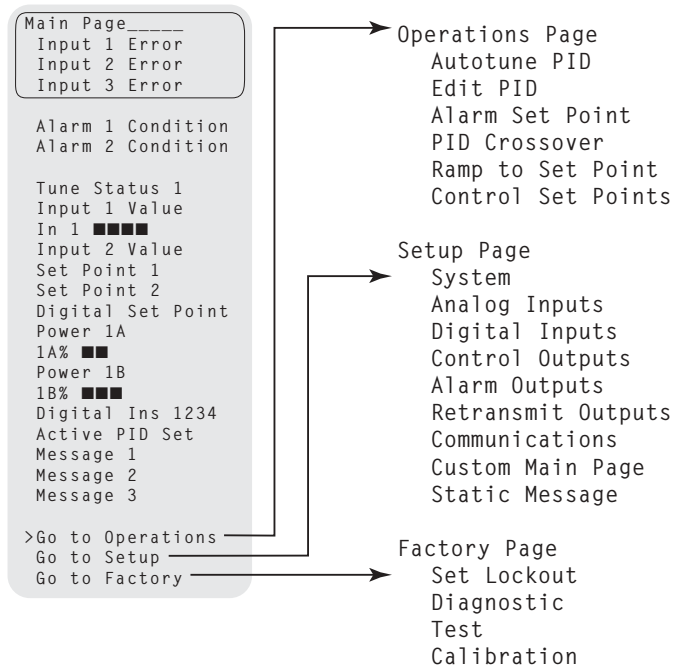

Figure 2.1 — Page Navigation.

Keys, Displays and Lights

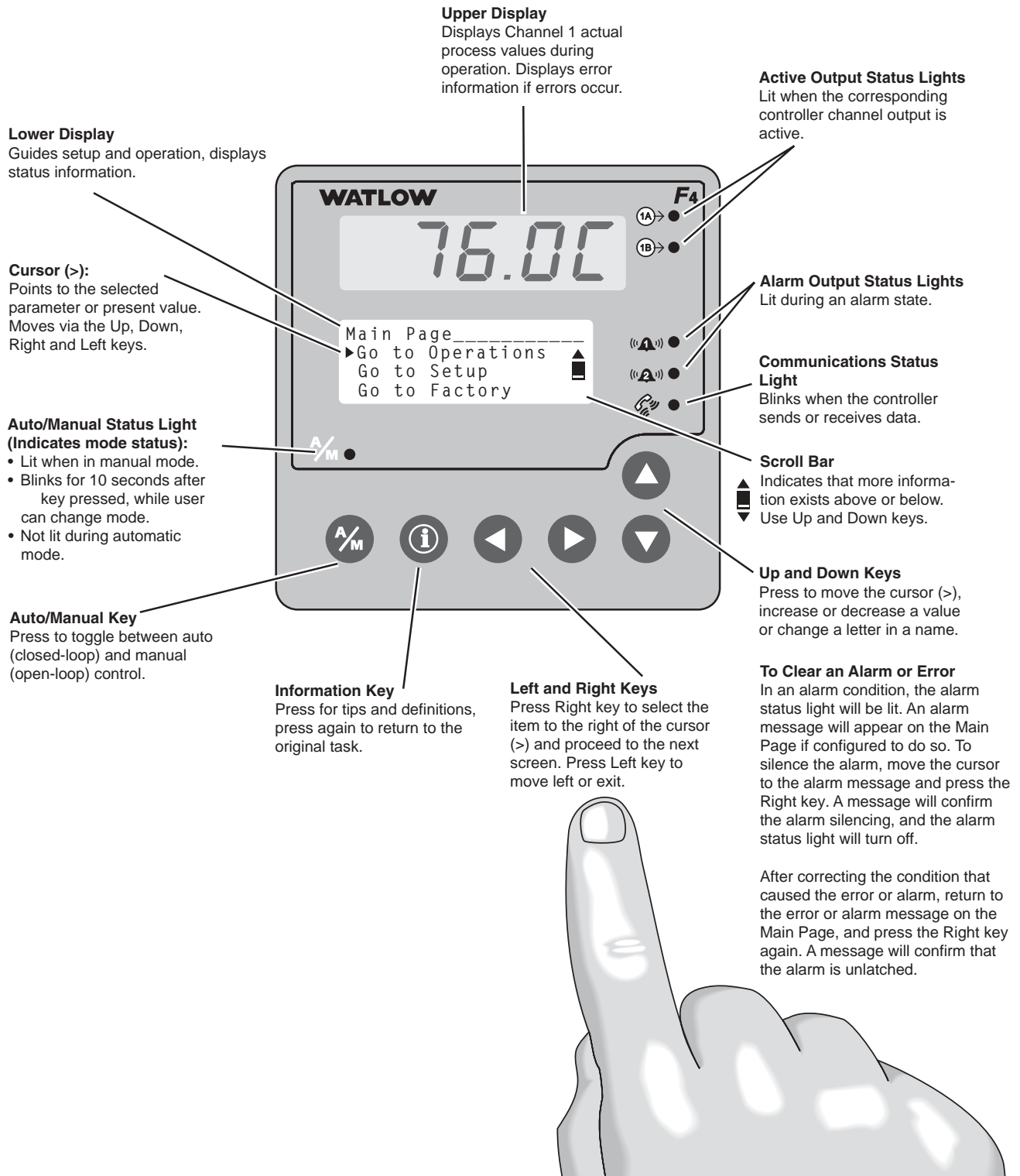





Figure 2.2 — Series F4P Displays and Indicator Lights.

Guided Programming

The Series F4P software guides users through most tasks. To accomplish a task, simply proceed through the sequence of parameters. For each parameter, choose the appropriate option or establish the value, then press the Right key to proceed to the parameter on the next screen. The task is complete when you return to the initial menu.

1. Use  or  to move the cursor to select an item in a list.
2. Press the Right key .
3. Enter the value and make a choice.
4. Press  again.
5. Repeat until you return to the original list.

To change a specific, single parameter, proceed through the parameter sequence without changing values until you reach that parameter, then make your change. After changing the value, you may back out of the sequence by pressing the Left key or continue on through the sequence by pressing the Right key. When you exit the page, you must choose to Save Changes or Restore Values.

```
Main Page_____▶
Go to Operations
>Go to Setup
Go to Factory
```

```
Choose to Setup:_____▶
>Control Output 1A
Control Output 2A
```

```
Choose Function:_____▶
>Heat
Cool
```

```
Choose Cycle Time:___
>Variable Burst
Fixed Time
```





Custom Main Page

The Main Page shows error messages; input and output status; and allows access to controller software. You can customize the Main Page to display chosen information by going to the Setup Page, Custom Main Page Menu. (See Chapter 4, Setup Page, for instructions.)

Auto and Manual Operation

The Series F4P controller can function as a **static set point** controller (auto mode); or the user can directly control the outputs (manual mode).

In the static set point mode, the Series F4P can only be operated in a closed-loop configuration.

The Auto/Manual Indicator Light is on when the controller is in manual mode. To toggle between manual and auto mode, first press the Auto/Manual key , then confirm your selection in the lower display. The indicator light will flash after you press  until you confirm your choice or 10 seconds have elapsed. While in manual mode you can adjust the output power level for process outputs or turn relay or open collector outputs on or off.

 **WARNING:** Only authorized and qualified personnel should change the set point on the controller. Failure to comply with these recommendations may result in damage to equipment and property and injury to personnel.

Static Set Point Control

When the Series F4P is in static set point mode:

- The Upper Display shows the actual process temperature of input 1.
- The Lower Display shows the default or user-configured Main Page.

To operate the Series F4P as a static set point controller, select SP1 in the Main Page then use the Up and Down keys to adjust the set point.

Limits may be placed on the set point in the Set Point Low Limit and Set Point High Limit parameters (Setup Page > Analog Input 1).

✓ **Note:** All control activity stops when you enter the Setup Page, Analog Input, Digital Input, Control Output, Alarm Output and Retransmit menus.

✓ **Note:** See also differential set point and ratio set point.

Troubleshooting

Indication	Probable Cause(s)	Corrective Action
Power		
<ul style="list-style-type: none"> No displays. 	<ul style="list-style-type: none"> Power to unit off. Fuse blown. Breaker tripped. Safety Interlock door switch, etc., activated. Separate system limit control latched. Wiring open. Input power incorrect. 	<ul style="list-style-type: none"> Check switches, fuses, breakers, interlocks, limits, connectors, etc. for energized conditions and proper connection. Measure power for required level. Check part number for input power required. Check wire size. Check for bad connections.
Communications		
<ul style="list-style-type: none"> Unit will not communicate. 	<ul style="list-style-type: none"> Address parameter incorrectly set. Baud rate parameter incorrectly set or incorrect protocol. Use Modbus RTU, 8 data bits, no parity and 1 stop bit. Unit-to-unit daisy chain disconnected. Communications wiring reversed, shorted or open. EIA-232 to EIA-485 converter incorrectly set or wired. Computer communications port incorrectly set up or defective. Termination and/or pull up of bus required. Serial cable is open or not wired correctly. Serial port of controller is defective. 	<ul style="list-style-type: none"> Check Communications Setup Menu and set to correct address. Check Communications Setup Menu and set to correct baud rate. Be sure it is Modbus RTU protocol. Look for a break in the daisy chain. Verify correct connections and test wiring paths. Converter must be half duplex. Check converter box wiring and settings. Check computer communications port settings and verify PC communications. Check converter box wiring and its documentation. Verify or replace serial cable. Return controller to factory for repair.
Alarms		
<ul style="list-style-type: none"> Alarm won't occur. 	<ul style="list-style-type: none"> Alarm silencing is enabled. Alarm output not configured. Controller in Diagnostic mode. Alarm annunciation is set to off. 	<ul style="list-style-type: none"> Verify that silencing function is required. Disable if not required. Configure alarm type, sides, hysteresis, logic and set points. Exit Diagnostic mode. Turn on alarm annunciation.
<ul style="list-style-type: none"> Alarm won't clear. <p>(To clear the alarm, correct the alarm condition. If the alarm is latched, press ○ with the cursor at the alarm message on the Main Page.)</p>	<ul style="list-style-type: none"> Alarm latched. Alarm output not configured correctly. Analog input(s) in error condition. Input may be in error condition. 	<ul style="list-style-type: none"> Process value must return to normal by more than the hysteresis value to be cleared. Configure alarm type, sides, hysteresis, logic and set points. Correct cause of input error. Check the alarm output function.

Indication	Probable Cause(s)	Corrective Action
<ul style="list-style-type: none"> Alarm output action is reversed. 	<ul style="list-style-type: none"> Alarm logic setting incorrect or output wired incorrectly. 	<ul style="list-style-type: none"> Check alarm logic setting and output wiring.
Controllability		
<ul style="list-style-type: none"> Process will not stabilize. 	<ul style="list-style-type: none"> Power limit set incorrectly. PID values set incorrectly. Incorrect PID set active. 	<ul style="list-style-type: none"> Check power limit settings. Tune PID set. Use correct PID set.
<ul style="list-style-type: none"> Process runs away (too high or too low). 	<ul style="list-style-type: none"> Controller in manual operation mode (percent power). Power limit set incorrectly. Thermocouple shorted. Shorted power switching device. Output set incorrectly (heat vs. cool). System wired incorrectly. 	<ul style="list-style-type: none"> Check operation mode. Automatic is closed loop, manual is open loop. Check power limit settings. Check sensor, repair or replace. Check outputs, repair or replace. Check output settings. Check system wiring.
<ul style="list-style-type: none"> Process will not reach set point. 	<ul style="list-style-type: none"> PID values set incorrectly. Power limit set incorrectly. Open fuse or circuit breaker on energy source. Incorrect sensor location in the process. Slidewire (if used) settings incorrect. 	<ul style="list-style-type: none"> Tune PID set. Check power limit settings. Replace fuse or reset circuit breaker. Reposition sensor to accurately measure process. Check slidewire settings.
Input Errors		
(Upper Display shows error code for input 1 only. Lower Display shows additional errors. Input 2 and 3 error messages appear in Lower Display. Alarm Output Indicator is lit.)		
Upper A-dL0 Lower !Input x AtoD+ (x is 1 to 3)	<ul style="list-style-type: none"> Sensor shorted (RTD). Sensor wired backwards. Display decreases as process increases. Input type set to wrong sensor. Ground loop 	<ul style="list-style-type: none"> Repair or replace sensor. Reverse sensor wiring connections. Red lead is usually negative for tc. Set analog input to match sensor. Check sensor isolation. Inputs 2 and 3 are not isolated from each other.
Upper A-dh1 Lower !Input x AtoD+ (x is 1 to 3)	<ul style="list-style-type: none"> Sensor open. Sensor wired backwards. Display decreases as process increases. Input type set to wrong sensor. Ground loop 	<ul style="list-style-type: none"> Repair or replace sensor. Reverse sensor wiring connections. Red lead is usually negative for tc. Set analog input to match sensor. Check sensor isolation. Inputs 2 and 3 are not isolated from each other.
Upper SEnLo Lower !Input Sensor x- (x is 1 to 3)	<ul style="list-style-type: none"> Sensor shorted (RTD). Sensor wired backwards. Display decreases as process increases. Input type set to wrong sensor. Ground loop 	<ul style="list-style-type: none"> Repair or replace sensor. Reverse sensor wiring connections. Red lead is usually negative for tc. Set analog input to match sensor. Check sensor isolation. Inputs 2 and 3 are not isolated from each other.
Upper SEnh1 Lower !Input Sensor x+ (x is 1 to 3)	<ul style="list-style-type: none"> Sensor open. Sensor wired backwards. Display decreases as process increases. Input type set to wrong sensor. Ground loop 	<ul style="list-style-type: none"> Repair or replace sensor. Reverse sensor wiring connections. Red lead is usually negative for tc. Set analog input to match sensor. Check sensor isolation. Inputs 2 and 3 are not isolated from each other.
Upper REod Lower !Timeout x (x is 1 to 3)	<ul style="list-style-type: none"> Component failure. 	<ul style="list-style-type: none"> Return to factory for evaluation.

Indication	Probable Cause(s)	Corrective Action
Upper Lower !Input x Error (x is 1 to 3)	<ul style="list-style-type: none"> • Component failure. 	<ul style="list-style-type: none"> • Return to factory for evaluation.
Upper Lower Slidewire time out	<ul style="list-style-type: none"> • Slidewire time out value set too short. • Slidewire valve is stuck or not responding. • Process valve is wired incorrectly or incompatible. 	<ul style="list-style-type: none"> • Increase slidewire time out value. • Replace process valve. • Increase slidewire time out value. • Check wiring and process valve for compatibility.
Upper Lower Slidewire time out	<ul style="list-style-type: none"> • Process valve is wired incorrectly or incompatible. 	<ul style="list-style-type: none"> • Check wiring and process valve for compatibility.
System Errors (Upper Display shows error numbers. Lower Display messages indicate cause and action to take.)		
<ul style="list-style-type: none"> • Zero Cross Failure! Switched to Fixed Time control. 	<ul style="list-style-type: none"> • Controller can't detect zero cross point. Noise is present on AC power line or unit is not powered by AC voltage. 	<ul style="list-style-type: none"> • Add filter to AC power line and verify unit is power by AC voltage.
<ul style="list-style-type: none"> • Unknown Error! Record this number. Contact the factory. 	<ul style="list-style-type: none"> • Component failure. 	<ul style="list-style-type: none"> • Contact factory for further information and diagnosis.
<ul style="list-style-type: none"> • Incorrect ID! 	<ul style="list-style-type: none"> • A module has lost its programming ID. 	<ul style="list-style-type: none"> • Replace module or return controller to factory for repair
<ul style="list-style-type: none"> • Verify Input 1 • Verify Input 2 or 3 	<ul style="list-style-type: none"> • Input module 2 or 3 is in input 1 slot. • Input module 1 is in input 2 or 3 slot. 	<ul style="list-style-type: none"> • Move module to correct input slot. • Move module to correct input slot.
<ul style="list-style-type: none"> • Output 1A • Output 1B • Output 2A • Output 2A 	<ul style="list-style-type: none"> • Output module failure. 	<ul style="list-style-type: none"> • Replace output module.
<ul style="list-style-type: none"> • Module not allowed 	<ul style="list-style-type: none"> • Module installed incorrectly or in wrong slot. 	<ul style="list-style-type: none"> • Check for correct installation of module.
<ul style="list-style-type: none"> • Verify the module. 	<ul style="list-style-type: none"> • Module not seated correctly in slot. 	<ul style="list-style-type: none"> • Check for correct installation of module.
<ul style="list-style-type: none"> • Retransmit 1 Module Error! Only process modules supported. 	<ul style="list-style-type: none"> • Wrong module in retransmit 2 slot. 	<ul style="list-style-type: none"> • Replace incorrect module with retransmit module.
<ul style="list-style-type: none"> • Retransmit 2 Module Error! Only process modules supported. 	<ul style="list-style-type: none"> • Wrong module in retransmit 2 slot. 	<ul style="list-style-type: none"> • Replace incorrect module with retransmit module.
<ul style="list-style-type: none"> • Module change. Defaults will occur. Accept with any key. 	<ul style="list-style-type: none"> • Module changed. 	<ul style="list-style-type: none"> • Press any key. All parameters will default.
<ul style="list-style-type: none"> • Checksum error in Cycle device power. 	<ul style="list-style-type: none"> • Noise on power line. • Component failure. 	<ul style="list-style-type: none"> • Add power line filter for input power. • Return controller to factory for repair.

Indication	Probable Cause(s)	Corrective Action
<ul style="list-style-type: none"> Module change. All parameters are initializing. 	<ul style="list-style-type: none"> Input or output module was changed. 	<ul style="list-style-type: none"> This is normal upon module change.
<ul style="list-style-type: none"> First power-up. Parameters are initializing. 	<ul style="list-style-type: none"> Controller powered up for the first time. 	<ul style="list-style-type: none"> Should not appear in the field. Call the factory if you get this message.
<ul style="list-style-type: none"> RAM Test Failed! Return controller to the Factory. 	<ul style="list-style-type: none"> Component failure. 	<ul style="list-style-type: none"> Return controller to factory for repair.
<ul style="list-style-type: none"> Flash Memory Failed! Return controller to the Factory. 	<ul style="list-style-type: none"> Power was interrupted during a flash update or there is a component failure. 	<ul style="list-style-type: none"> Return controller to factory for repair.
<ul style="list-style-type: none"> Firmware change. Parameters are initializing. 	<ul style="list-style-type: none"> Controller firmware has been updated. 	<ul style="list-style-type: none"> Normal operation following flash update of firmware.
<ul style="list-style-type: none"> Checksum Error! Parameter memory. Checksum Error! Unit Config memory Checksum Error! Profile memory. 	<ul style="list-style-type: none"> Power line noise has corrupted memory. 	<ul style="list-style-type: none"> Turn the controller off, then on again. If problem persists, power line filter is required.
<ul style="list-style-type: none"> RAM Test Failed! Return controller to the Factory. 	<ul style="list-style-type: none"> Controller has failed. 	<ul style="list-style-type: none"> Return controller to factory for repair.
<ul style="list-style-type: none"> Flash memory Failed. Return controller to the Factory. 	<ul style="list-style-type: none"> Controller has failed. 	<ul style="list-style-type: none"> Return controller to factory for repair.
<p>Open Loop Detect (Upper Display shows error code for input 1 only. Lower Display shows additional errors. Upper: OLP Lower: Open Loop</p>	<ul style="list-style-type: none"> Sensor not properly located Output relay open or shorted. Sensor shorted. Heater/cooling non-functional. 	<ul style="list-style-type: none"> Check all wiring and components. Turn the controller off, then on again. Place sensor near source. Replace relay. Replace sensor. Repair heating/cooling circuits. Check circuit breakers, switches, heater elements, compressor.

Notes:

Chapter Three: Operations Page

Alarm Set Points	3.1
Autotune PID	3.2
Edit PID	3.2
Multiple PID Sets	3.3
Cascade Tuning	3.3

This chapter explains how to establish alarm set points, autotune and manually tune and establish cascade control through the Operations Page of the software.

To configure the alarm outputs, go to the Setup Page of the software (see related information in the Parameters Chapter).

For the alarm clearing procedure, go to the Troubleshooting Alarms and Errors table in the Navigation and Operating from the Front Panel Chapter.

For background information about alarms; proportional, integral and derivative control; and cascade, see the Features Chapter.

Alarm Set Points

The Series F4P includes two alarm outputs, which can be programmed as process, deviation or rate alarms.

Process alarms notify the operator when process values exceed or fall below Alarm Low and Alarm High Set Points. Deviation alarms notify the operator when the process has deviated from the set point beyond the deviation limits. Rate alarms are triggered by a change in temperature or process value that is faster than the selected rate.

For more information, see the Features Chapter. To set up the alarms, see the Setup Chapter.

Alarm set points are the points at which alarms switch on or off, depending on the alarm setting. Alarm set points can be viewed or changed in the Alarm Set Point Menu (Operations Page).

The **Alarm High Set Point** defines the high value that, if exceeded, will trigger an alarm. This value must be higher than the alarm low set point and lower than the high limit of the sensor range.

The **Alarm Low Set Point** defines the low value that, if exceeded, will trigger an alarm. This value must be lower than the alarm high set point and higher than the low limit of the sensor range.

The **Alarm Low Deviation** defines the deviation value on the low side of set point at which the alarm will be triggered.

The **Alarm High Deviation** defines the deviation value on the high side of set point at which the alarm will be triggered.

✓ **Note:** You may want to set up the alarms with names that will identify the alarm conditions. See the Setup Page.

To Clear an Alarm or Error

In an alarm condition, the alarm status light will be lit. An alarm message will appear on the Main Page if configured to do so. To silence an alarm, the Silencing option in the Alarm Output menu (Setup Page) must be enabled. To silence the alarm, move the cursor to the alarm message and press the Right key. A message will confirm the silencing of the alarm, and the alarm status light will turn off. After correcting the condition that caused the error or alarm, return to the error or alarm message on the Main Page, and press the Right key again. A message will confirm that the alarm is unlatched.

Autotune PID

In autotuning, the controller automatically selects the PID parameters for optimal control, based on the thermal response of the system. In the Series F4P, five sets of PID values are available. Default PID values exist for all PID sets, although these values typically do not provide optimal control. PID values can be auto-tuned or adjusted manually. When autotuning is complete, the PID values will be stored in the Edit PID Menu.

Set point changes for remote, ratio and differential control are ignored until autotuning is complete.

Autotuning Procedure

Autotuning is initiated from the Operation Menu.

1. Before initiating auto-tune, go to the System Menu (Setup Page), and establish the Autotune Set Point to a percentage of set point. This percentage is based on your knowledge of the system and how much overshoot or undershoot there is likely to be in on-off control.

Select to display Tune Status in the Custom Main Page Menu.

2. Go to the Main Page and adjust set point.
3. Go to the Autotune PID Menu (Operations Page) and choose the PID set in which to store the values. You must exit back to Main Page with the left arrow. A message will be displayed on the Main Page during the autotuning process.
4. When autotuning is complete, the controller will store the values for optimum control in the specified PID set.

For additional information about autotuning and proportional, integral and derivative control, see the Features Chapter.

✓ **Note:** While the controller is autotuning, only the Operation Page of the software can be entered.



CAUTION: Choose an autotune set point value that will protect your product from possible damage from overshoot or undershoot during the autotuning oscillations. If the product is sensitive, select the autotune set point very carefully to prevent product damage.

Edit PID

The Edit PID Menu is useful when Auto-tune PID does not provide adequate control. Each of the PID parameters can be adjusted manually:

Proportional Band: Define a band for PID control, entered in degrees or units. Lower values increase gain, which reduces droop but can cause oscillation. Increase the proportional band to eliminate oscillation.

Integral (Reset): Define the integral time in minutes per repeat; define reset in repeats per minute. Set repeats per minute if units are U.S.; minutes per repeat if units are SI.

Derivative (Rate): Define the derivative (rate) time in minutes. Large values prevent overshoot but can cause sluggishness. Decrease if necessary.

Dead Band: Define the dead band in degrees or units. Heating dead band shifts the set point down. Cooling dead band shifts the set point up. For more information, see the Features Chapter.

For background information, see Chapter 7, Features.

Manual Tuning Procedure

1. Apply power to the Series F4P and establish a set point on the Main Page.
2. Establish Cycle Time in the Control Output Menu (Setup Page), as required. Typical cycle times are 1.0 second for an SSR and 5.0 seconds for a mechanical relay. Faster cycle times sometimes achieve the best system control. However, if a mechanical contactor or solenoid is switching power to the load, a longer cycle time may be desirable to minimize wear on the mechanical components. Experiment until the cycle time is consistent with the desired quality of control.
3. Go to the Edit PID Menu (Operations Page), and choose the channel and PID set. Establish values for the PID parameters: Proportional Band, 5; Integral (Reset), 0; Derivative (Rate), 0; and Autotune, Tune Off. Tuning begins when you choose a PID set.
4. When the system stabilizes, watch the value of Input 1 on the Main Page. If this value fluctuates, increase the proportional band setting until it stabilizes. Adjust the proportional band in 3° to 5° increments, allowing time for the system to stabilize between adjustments.
5. When Input 1 has stabilized, watch the percent power on the Main Page. It should be stable, $\pm 2\%$. At this point, the process temperature should also be stable, but it will exhibit droop (stabilized below set point). The droop can be eliminated with integral (reset).

6. Start with an integral setting of 99.9 minutes and allow 10 minutes for the process temperature to get to set point. If it has not, decrease the setting by half and wait another 10 minutes. Then halve the setting again and wait another 10 minutes until the process value equals the set point. If the process becomes unstable, the integral value is too small. Increase it until the process stabilizes.
7. Increase Derivative/Rate to 0.10 minute. Then increase the set point by 11° to 17°C. Watch the system's approach to the set point. If the process value overshoots the set point, increase Derivative/Rate to 0.50 minute.

Increase the set point by 11° to 17°C and watch the approach to the new set point. If you increase Derivative/Rate too much, the approach to the set point will be very sluggish. Repeat as necessary until the system rises to the new set point without overshoot or sluggishness.

For additional information about the burst fire feature, manual tuning and PID control, see the Features Chapter.

Multiple PID Sets

Environmental chambers, ovens and furnaces typically have different thermal requirements at high and low temperatures or pressures. To accommodate this, the Series F4P can store five different PID sets.

Multiple Tuning Procedure

To autotune multiple PID sets, follow the Autotuning procedure above for each PID set. When autotuning is finished for one set, proceed with another.

Cascade

Cascade control is available on enhanced (F4P _ _ _ AB _ _ _ _ _) Series F4P controllers. For background information about cascade control, see the Features Chapter.

Select cascade control through the Analog Input 3 Menu (Setup Page), and choose Process Cascade or Deviation Cascade. To set the range for the inner loop set point, Process Cascade uses Low and High Range settings that are independent of set point; Deviation Cascade uses Deviation Low and High settings that are deviations from the primary set point.

When tuning a cascade system, the inner loop must be tuned first. The inner loop comprises outputs 1A and 1B and the Analog Input 1 sensor, which usually measures the energy source temperature. The output device controls a power switching device, which in turn switches

the heating and cooling. The set point for the inner loop is generated by the outer loop. For Process Cascade, this will have a range between the Cascade Low Range and Cascade High Range.

Cascade Setup Procedure

1. First, configure Analog Input 3, Cascade Low Range and Cascade High Range.

Go to the Analog Input 3 Menu (Setup Page). Choose Process or Deviation Cascade. Deviation Cascade references Channel 1 set point allowing a range above and below the current control set point. For Process Cascade control of a heat/cool or cool only system, set the Cascade Low Range to a value slightly lower than the lowest temperature desired in the chamber. For heat-only systems, set the Cascade Low Range to a value slightly lower than the ambient temperature; otherwise the heat output will never turn fully off.

For heat/cool or heat only systems, set the Cascade High Range to a value slightly higher than the highest temperature desired in the chamber. For cool-only systems, set the Cascade High Range to a value slightly higher than the ambient temperature; otherwise the cooling will never fully turn off.

2. Next, configure the controller to tune and display data for the outer loop. To view Inner Loop Set Point in the upper display, go to the Setup Page, Custom Main Page Menu, select the Inner Set point as one of the parameters, P1 to P16, to be displayed in the Main Page.

To also view Analog Input 3 in the upper display, go to the Setup Page, Process Display Menu, and choose Alternating. Under Set Display Time, choose a duration for the display of the Input 1 and Input 3 variables.

Cascade Autotuning Procedure

1. Go to Setup Page, Custom Main Page Menu. Choose Tune Status 1 and Tune Status 2 to appear as 2 of the 16 parameters that can be displayed on the Main Page. The Main Page will now display the status of the autotuning process.
2. Autotune the inner loop. Go to the Autotune PID Menu (Operations Page), and select Cascade Inner-loop. Choose Cascade Inner Loop PID Set 1 to 5, where PID values will be stored after autotuning. Autotuning begins when you choose the PID set. While autotuning, the F4 controller will control the energy source in an on-off mode to a temperature equal to the Cascade High Range setting x Channel 1 Autotune Set Point. For best results, use proportional control only on the inner loop.

3. Next, autotune the outer loop. Go to the Autotune PID Menu (Operations Page). Choose Cascade Outer Loop, then choose Outer Loop PID set 1 to 5, where PID values will be stored after autotuning. Autotuning begins when you choose the PID set. While autotuning, the outer loop will be controlled in an on-off mode at a set point equal to static set point x Ch 1 Autotune Set Point. In most cases, the autotuning feature will tune for acceptable control. If not, manually tune the outer loop (step 4 below). Before manually tuning, record the values generated by the autotuning feature.
4. To manually tune the outer loop, go to the Edit PID Menu (Operations Page). Choose Cascade Outer Loop, then choose Outer Loop PID set 1 to 5. Begin manual tuning by setting the Proportional Band to 5, Integral (Reset) to 0, and Rate to 0. Establish the desired set point and let the system stabilize. When the system stabilizes, watch the Inner Loop Set Point on the Main Page. If this value fluctuates, increase the proportional band until it stabilizes. Adjust the proportional band in 3° to 5° increments, allowing time for the system to stabilize between adjustments.
5. When Input 1 has stabilized, watch the percent power on the Main Page. It should be stable, $\pm 2\%$. At this point, the process temperature should also be stable, but it will exhibit droop (stabilized below set point). The droop can be eliminated with Integral (reset).
6. Start with an integral setting of 99.9 minutes, and allow 10 minutes for the process temperature to come up to set point. If it has not, decrease the setting by half and wait another 10 minutes. Then halve the setting again and wait another 10 minutes until the process value equals the set point. If the process becomes unstable, the integral value is too small. Increase it until the process stabilizes.

Chapter Four: Setup Page

Parameter Setup Order	4.1
Customizing the Main Page	4.2
Static Messages	4.2

This chapter explains how to configure the controller software through the Setup Page menus. Setup Page parameters affect the way the controller responds to your application, which parameters and functions are visible in other pages, and the way information is displayed on the Main Page. Set up the controller properly to provide a sound foundation for settings in other pages.

For ranges, defaults and other information about specific parameters, see the Parameters Chapter. Record your settings in the Parameter Setup Record, also in that chapter.

For background information about inputs, outputs, alarms and other features, see the Features Chapter.

Parameter Setup Order

Initial configuration of the Series F4P is best done in the following order:

- Go to the System Menu (Setup Page) to configure:
 - PID units — SI (Integral, Derivative) or U.S. (Reset, Rate);
 - Celsius or Fahrenheit scales;
 - display of units in the controller's upper display;
 - Autotune set point;
 - open-loop detection warnings; and
 - controller response to a power outage.
- Go to other menus on the Setup Page to configure:
 - Analog Input x (1 to 3);
 - Digital Input x (1 to 4);
 - Control Output x (1A, 1B);
 - Alarm Output x (1 or 2);
 - Retransmit Output x (1 or 2);
 - Communications; and
 - Custom Main Page and Custom Messages.

3. Go to the Operations Page to tune the PID sets.

4. Go to the Operations Page to set the alarm set points.

After this initial configuration, the most frequent changes will be to the Operations Page (alarm set points and PID sets).

If the Series F4P is already installed in an environmental chamber, oven, furnace or other equipment, most parameters will already be configured and access to the Setup Page may be limited (see Chapter 5, Factory Page).

Changing Setup Page parameters may change other parameters. In some cases, a change in one parameter will affect the defaults of others. To see how all the pages, menus and parameters are grouped, see the software map on the inside back cover of this manual.

✓ **Note:** For more information about how parameter settings affect the controller's operation, see the Features Chapter.

⚠ WARNING: Only authorized and qualified personnel should change the factory-default settings, which may cause changes in other settings. Failure to comply with this recommendation may result in damage to equipment and property and injury to personnel.

Customizing the Main Page

Up to 16 lines can be added to the Main Page to display status and information from the controller.

Go to the Custom Main Page Menu on the Setup Page. The first screen will prompt you to choose one of the 16 lines to customize. "P1 Parameter" is the first line; "P16 Parameter" is the 16th. After choosing this line by pressing **⏏**, select a parameter to monitor.

Your choices are listed under Custom Main Page in the Setup Page Parameter Table in this chapter.

```
Choose: _ _ _ _ _ _ _ _  
>P1 Parameter  
P2 Parameter      ■  
P3 Parameter      ▼
```

```
Choose P:1 Display_ _  
>None  
Input 1 Value     ■  
Input 1 Value bar ▼
```

```
Input1           26°C  
PID Set          1  
Power1A          0%  
Power1B          55%  
DigitalIn       _234
```

Figure 4.2 — Example of Parameters on the Custom Main Page.

Static Messages

Digital inputs can be configured to display a message that the user enters. The message is displayed on the Main Page when the digital input is active.

This feature could, for instance, display "DOOR OPEN" if an oven door is not closed all the way.

5

Chapter Five: Factory Page

Security5.1
Diagnostics5.3
Calibration5.3

Security

The Series F4P allows users to set separate security levels for the Static Set Point prompt on the Main Page, for all menus on the Operations Page, as well as for the Setup Page and Factory Page. Four levels of security are available:

- **Full Access** (operators can enter and change settings);
- **Read Only** (operators can read but not change settings);

- **Password** (operators can enter and change settings after entering a password); and
- **Hidden** (operators cannot see the menu or page — it is not displayed). Set Point settings cannot be Hidden.

✓ **Note:** Full Access is the default for all menus. Unless you change the level of access, operators will be able to read and change every setting in every menu in the Series F4P software.

How to Set Lockout Levels

Using the Lockout Menu, you can limit access to the following menus and pages:

- **Set Point** on Main Page
- **Operations Page Autotune PID**
- **Operations Page Edit PID**
- **Operations Page Alarm Set Point**
- **Setup Page**
- **Factory Page**

Choose the item to lock out, press  and choose the level of access: Full, Read Only, Password or Hidden. If you choose Password, you must set the password — see below.

✓ **Note:** For more information about how parameter settings affect the controller's operation, see the Features Chapter.

 **CAUTION:** Only authorized and qualified personnel should be allowed to perform preventive and corrective maintenance on this unit.

```
Main>Factory_____▶  
>Set Lockout  
Diagnostic  
Test
```

```
...Factory>Set Lock____▶  
Set Point  
>Oper. Autotune PID ■  
Oper. Edit PID ▼
```

```
...Lock>Autotune PID____  
Full Access  
Read Only  
>Password
```

Diagnostics

Diagnostic Menu parameters (on the Factory Page) provide information about the controller unit that is useful in troubleshooting. For example, the Out1A parameter will identify what type of output has been selected for Output 1A.

Select the parameter by pressing the Right Key **➤**. The information will appear on the Lower Display.

Some of the parameters in the Diagnostic Menu provide information for factory use only.

To reset all parameters to their original factory values, use the Full Defaults parameter under the Test Menu.

Test

This menu allows you to test outputs, test the displays (upper, lower and status lights), and cause the controller to revert to the defaults set at the factory. Reverting to factory defaults will erase all preset software and the controller will return to U.S. PID units (Reset and Rate) and the Fahrenheit temperature scale.

Calibration

The Calibration Menu on the Factory Page allows calibration of inputs and outputs. Calibration procedures should be done only by qualified technical personnel with access to the equipment listed in each section.

Before beginning calibration procedures, warm up the controller for at least 20 minutes.

Restore Factory Values

Each controller is calibrated before leaving the factory. If at any time you want to restore the factory input calibration values, use the last parameters in the menu: Restore Input x (1 to 3) Calibration. Press **➤**. No special equipment is necessary.

Thermocouple Input Procedure

Equipment

- Type J reference compensator with reference junction at 32°F/0°C, or type J thermocouple calibrator to 32°F/0°C.
- Precision millivolt source, 0 to 50mV minimum range, 0.002mV resolution.

Input x (1 to 3) Setup and Calibration

Inputs 2 and 3 appear only if the controller is the enhanced version (F4P _ - _ _ AB - _ _ _ _).

1. Connect the correct power supply to terminals 1, 2 and 3 (see the Wiring Chapter and the Appendix).
2. Connect the millivolt source to input 1 terminals 62 (-) and 61 (+), input 2 terminals 58 (-) and 57 (+), or input 3 terminals 56 (-) and 55 (+), with copper wire.
3. Enter 50.000mV from the millivolt source. Allow at least 10 seconds to stabilize. Press the Right Key **➤** once at the Calibrate Input x (1 to 3) prompt (Factory Page). At the 50.00mV prompt press **➤** once and to store 50.00mV press the Up Key **▲** once.
4. Enter 0.000mV from the millivolt source. Allow at least 10 seconds to stabilize. At the 0.00mV prompt press **➤** once and to store 0.00mV press **▲** once.
5. Disconnect the millivolt source and connect the reference compensator or thermocouple calibrator to input 1 terminals 62 (-) and 61 (+), input 2 terminals 58 (-) and 57 (+), or input 3 terminals 56 (-) and 55 (+). With type J thermocouple wire, if using a compensator, turn it on and short the input wires. When using a type J calibrator, set it to simulate 32°F/0°C. Allow 10 seconds for the controller to stabilize. Press **➤** once at the Calibrate Input x (1 or 2) prompt (Factory Page). At the 32°F Type J prompt press **➤** once and to store type J thermocouple calibration press **▲** once.
6. Rewire for operation and verify calibration.

RTD Input Procedure

Equipment

- 1k Ω decade box with 0.01 Ω resolution.

Input x (1 to 3) Setup and Calibration

1. Connect the correct power supply to terminals 1, 2 and 3 (see the Wiring Chapter and the Appendix).
2. Short Input 1 terminals 60, 61 and 62; Input 2 terminals 54, 57 and 58; or Input 3 terminals 52, 55 and 56 together with less than 0.1 Ω . Press the Right Key **➤** once at the Calibrate Input x (1 to 3) prompt. At the Ground prompt press **➤** once and to store ground input press the Up Key **▲** once.
3. Short Input 1 terminals 60 and 61; Input 2 terminals 54 and 57; or Input 3 terminals 52 and 55 together with less than 0.5 Ω . Press **➤** once at the Calibrate Input x (1 to 3) prompt. At the Lead prompt press **➤** once and to store lead resistance press **▲** once.
4. Connect the decade box to Input 1 terminals 60 (S2), 61 (S1) and 62 (S3); Input 2 terminals 54 (S2), 57 (S1) and 58 (S3); or Input 3 terminals 52 (S2), 55 (S1) and 56 (S3), with 20- to 24-gauge wire.
5. For 100 Ω RTD, enter 15.00 Ω . For 500 Ω or 1k Ω RTD, enter 240.00 Ω . Allow at least 10 seconds to stabilize. Press **➤** once at the Calibrate Input x (1 to 3) prompt (Factory Page). At the 15.00 Ω or 240.00 Ω * RTD prompt press **➤** once and to store the 15.00 Ω or 240.00 Ω input press **▲** once.
6. For 100 Ω RTD, enter 380.00 Ω . For 500 Ω or 1k Ω RTD, enter 6080.00 Ω . Allow at least 10 seconds to stabilize. Press **➤** once at the Calibrate Input x (1 to 3) prompt. At the 380.0 Ω or 6080.00 Ω * RTD prompt press **➤** once and to store the 380.00 Ω or 6080.00 Ω input press **▲** once.
7. Rewire for operation and verify calibration.

✓ NOTE:

You need the equipment listed and technical skills. Controllers come calibrated from the factory. Recalibrate only for other agency requirements or if temperatures aren't accurate as verified by another calibrated instrument.

Slidewire Feedback Input Procedure

Equipment

- 1k Ω decade box with 0.01 Ω resolution.

Input 3 Setup and Calibration

Input 3 appears only if the controller is the enhanced version (F4P _ - _ _ AB - _ _ _ _).

1. Connect the correct power supply to terminals 1, 2 and 3 (see the Wiring Chapter and the Appendix).
2. Connect the decade box to Input 3 terminals 55 (S1) and 56 (S3), with 20- to 24-gauge wire.
3. Enter 15.00 Ω . on the decade box. Allow at least 10 seconds to stabilize. Press **➤** once at the Calibrate Input 3 prompt (Factory Page). At the 15.00 Ω SIWr prompt press **➤** once and to store the 15.00 Ω input press **▲** once.
4. Enter 1000.00 Ω . from the decade box. Allow at least 10 seconds to stabilize. Press **➤** once at the Calibrate Input 3 prompt. At the 1000.00 Ω SIWr prompt press **➤** once and to store the 380.00 Ω or 6080.00 Ω input press **▲** once.
5. Rewire for operation and verify calibration.

Voltage Process Input Procedure

Equipment

- Precision voltage source, 0 to 10V minimum range, with 0.001V resolution.

Input x (1 to 3) Setup and Calibration

Inputs 2 and 3 appear only if the controller is the enhanced version (F4P _ - _ _ AB - _ _ _ _).

1. Connect the correct power supply to terminals 1, 2 and 3 (see the Wiring Chapter and the Appendix).
2. Connect the voltage source to input 1 terminals 59 (+) and 62 (-), input 2 terminals 53 (+) and 58 (-) or input 3 terminals 51 (+) and 56 (-).
3. Enter 0.000V from the voltage source to the controller. Allow at least 10 seconds to stabilize. Press the Right Key **➤** once at the Calibrate Input 1 prompt. At the 0.000V prompt press **➤** once and to store the 0.000V input press the Up Key **▲** once.

*The tenth digit of your model number, F4XX-XXXX-~~XXXX~~, determines what prompts appear and what input resistance values to use for RTD calibration. Refer to the Ordering Information in the Appendix.

4. Enter 10.000V from the voltage source to the controller. Allow at least 10 seconds to stabilize. Press **▶** once at the Calibrate Input 1 prompt. At the 10.000V prompt press **▶** once and to store the 10.000V input press **▲** once.
5. Rewire for operation and verify calibration.

Current Process Input Procedure

Equipment

- Precision current source, 0 to 20mA range, with 0.01mA resolution.

Input x (1 to 3) Setup and Calibration

Inputs 2 and 3 appear only if the controller is the enhanced version (F4P _ - _ _ AB - _ _ _ _).

1. Connect the correct power supply to terminals 1, 2 and 3 (see the Wiring Chapter and the Appendix).
2. Connect the current source to input 1 terminals 60 (+) and 62 (-), input 2 terminals 54 (+) and 58 (-), or input 3 terminals 52 (+) and 56 (-).
3. Enter 4.000mA from the current source to the controller. Allow at least 10 seconds to stabilize. Press the Right Key **▶** once at the Calibrate Input 1 prompt. At the 4.000mA prompt press **▶** once and to store 4.000mA press the Up Key **▲** once.
4. Enter 20.000mA from the current source to the controller. Allow at least 10 seconds to stabilize. Press **▶** once at the Calibrate Input 1 prompt. At the 20.000mA prompt press **▶** once and to store 20.000mA press **▲** once.
5. Rewire for operation and verify calibration.

Process Output Procedure

Equipment

- Precision volt/ammeter with 3.5-digit resolution.

Output 1A Setup and Calibration

1. Connect the correct power supply to terminals 1, 2 and 3 (see the Wiring Chapter and the Appendix).

Milliamperes

2. Connect the volt/ammeter to terminals 42 (+) and 43 (-).
3. Press the Right Key **▶** at the Calibrate Output 1A prompt. At the 4.000mA prompt press **▶** once. Use the Up Key **▲** or the Down Key **▼** to adjust the display to the reading on the volt/ammeter. The controller should stabilize within one second. Repeat until the volt/ammeter reads 4.000mA. Press **▶** to store the value.
4. Press the Right Key **▶** at the Calibrate Output 1A prompt. At the 20.000mA prompt press **▶** once. Use the Up Key **▲** or the Down Key **▼** to adjust the

display to the reading on the volt/ammeter. The controller should stabilize within one second. Repeat until the volt/ammeter reads 20.000mA. Press **▶** to store the value.

Volts

5. Connect the volt/ammeter to terminals 44 (+) and 43 (-).
6. Press the Right Key **▶** at the Calibrate Output 1A prompt. At the 1.000V prompt press **▶** once. Use the Up Key **▲** or the Down Key **▼** to adjust the display to the reading on the volt/ammeter. The controller should stabilize within one second. Repeat until the volt/ammeter reads 1.000V. Press **▶** to store the value.
7. Press the Right Key **▶** at the Calibrate Output 1A prompt. At the 10.000V prompt press **▶** once. Use the Up Key **▲** or the Down Key **▼** to adjust the display to the reading on the volt/ammeter. The controller should stabilize within one second. Repeat until the volt/ammeter reads 10.000V. Press **▶** to store the value.
8. Rewire for operation and verify calibration.

Output 1B Setup and Calibration

1. Connect the correct power supply to terminals 1, 2 and 3 (see the Wiring Chapter and the Appendix).

Milliamperes

2. Connect the volt/ammeter to terminals 39 (+) and 40 (-).
3. Press the Right Key **▶** at the Calibrate Output 1B prompt. At the 4.000mA prompt press **▶** once. Use the Up Key **▲** or the Down Key **▼** to adjust the display to the reading on the volt/ammeter. The controller should stabilize within one second. Repeat until the volt/ammeter reads 4.000mA. Press **▶** to store the value.
4. Press the Right Key **▶** at the Calibrate Output 1B prompt. At the 20.000mA prompt press **▶** once. Use the Up Key **▲** or the Down Key **▼** to adjust the display to the reading on the volt/ammeter. The controller should stabilize within one second. Repeat until the volt/ammeter reads 20.000mA. Press **▶** to store the value.

Volts

5. Connect the volt/ammeter to terminals 41 (+) and 40 (-).
6. Press the Right Key **▶** at the Calibrate Output 1B prompt. At the 1.000V prompt press **▶** once. Use the Up Key **▲** or the Down Key **▼** to adjust the display to the reading on the volt/ammeter. The controller should stabilize within one second. Repeat until the volt/ammeter reads 1.000V. Press **▶** to store the value.

7. Press the Right Key **➤** at the Calibrate Output 1B prompt. At the 10.000V prompt press **➤** once. Use the Up Key **▲** or the Down Key **▼** to adjust the display to the reading on the volt/ammeter. The controller should stabilize within one second. Repeat until the volt/ammeter reads 10.000V. Press **➤** to store the value.
8. Rewire for operation and verify calibration.

Retransmit Output Procedure

Equipment

- Precision volt/ammeter with 3.5-digit resolution.

Retransmit 1 Setup and Calibration

1. Connect the correct power supply to terminals 1, 2 and 3 (see the Wiring Chapter and the Appendix).

Milliamperes

2. Connect the volt/ammeter to terminals 50 (+) and 49 (-).
3. Press the Right Key **➤** at the Calibrate Rexmit 1 prompt. At the 4.000mA prompt press **➤** once. Use the Up Key **▲** or the Down Key **▼** to adjust the display to the reading on the volt/ammeter. The controller should stabilize within one second. Repeat until the volt/ammeter reads 4.000mA. Press **➤** to store the value.
4. Press the Right Key **➤** at the Calibrate Rexmit 1 prompt. At the 20.000mA prompt press **➤** once. Use the Up Key **▲** or the Down Key **▼** to adjust the display to the reading on the volt/ammeter. The controller should stabilize within one second. Repeat until the volt/ammeter reads 20.000mA. Press **➤** to store the value.

Volts

5. Connect the volt/ammeter to terminals 48 (+) and 49 (-).
6. Press the Right Key **➤** at the Calibrate Rexmit 1 prompt. At the 1.000V prompt press **➤** once. Use the Up Key **▲** or the Down Key **▼** to adjust the display to the reading on the volt/ammeter. The controller should stabilize within one second. Repeat until the volt/ammeter reads 1.000V. Press **➤** to store the value.
7. Press the Right Key **➤** at the Calibrate Rexmit 1 prompt. At the 10.000V prompt press **➤** once. Use the Up Key **▲** or the Down Key **▼** to adjust the display to the reading on the volt/ammeter. The controller should stabilize within one second. Repeat until the volt/ammeter reads 10.000V. Press **➤** to store the value.
8. Rewire for operation and verify calibration.

Retransmit 2 Setup and Calibration

1. Connect the correct power supply to terminals 1, 2 and 3 (see the Installing and Wiring Chapter and the Appendix).

Milliamperes

2. Connect the volt/ammeter to terminals 47 (+) and 46 (-).
3. Press the Right Key **➤** at the Calibrate Rexmit 2 prompt. At the 4.000mA prompt press **➤** once. Use the Up Key **▲** or the Down Key **▼** to adjust the display to the reading on the volt/ammeter. The controller should stabilize within one second. Repeat until the volt/ammeter reads 4.000mA. Press **➤** to store the value.
4. Press the Right Key **➤** at the Calibrate Rexmit 2 prompt. At the 20.000mA prompt press **➤** once. Use the Up Key **▲** or the Down Key **▼** to adjust the display to the reading on the volt/ammeter. The controller should stabilize within one second. Repeat until the volt/ammeter reads 20.000mA. Press **➤** to store the value.

Volts

5. Connect the volt/ammeter to terminals 45 (+) and 46 (-).
6. Press the Right Key **➤** at the Calibrate Rexmit 2 prompt. At the 1.000V prompt press **➤** once. Use the Up Key **▲** or the Down Key **▼** to adjust the display to the reading on the volt/ammeter. The controller should stabilize within one second. Repeat until the volt/ammeter reads 1.000V. Press **➤** to store the value.
7. Press the Right Key **➤** at the Calibrate Rexmit 2 prompt. At the 10.000V prompt press **➤** once. Use the Up Key **▲** or the Down Key **▼** to adjust the display to the reading on the volt/ammeter. The controller should stabilize within one second. Repeat until the volt/ammeter reads 10.000V. Press **➤** to store the value.
8. Rewire for operation and verify calibration.

6

Chapter Six: Parameters

Pages, Menus and Parameters	6.1
Main Page	6.2
Operations Page Parameter Table	6.4
Operations Page Parameter Record	6.10
Setup Page Parameter Table	6.11
Setup Page Parameter Record	6.23
Custom Main Page Parameter Record	6.25
Factory Page Parameter Table	6.26

Pages, Menus and Parameters

The Series F4P parameters are arranged into four groups, or pages: Main; Operations, Setup and Factory. See the chapters about each page for additional information. The Features Chapter provides information about features, such as alarms, and the parameters that apply to them.

Only active parameters will appear on the controller. If, for instance, Output 1B is set to Off, no other output 1B parameters will appear.

Changing some parameters will force changes to other parameter settings. The safest and most efficient way to configure the Series F4P controller for the first time is to configure the parameters in the Setup Page in the order in which they appear.

It may also be helpful for you to make copies of the Parameter Records for each of the pages, as well as the Custom Main Page Record, then record your settings for future reference.

✓ **Note:** If the Series F4P is already installed in an oven, furnace or other equipment, most parameters will already be configured and access to the Setup Page may be limited (locked).

✓ **Note:** To see how all the pages, menus and parameters are grouped, see the software map on the inside back cover of this manual.

✓ **Note:** For more information about how parameter settings affect the controller's operation, see the Features Chapter.

Main Page Parameters

Parameter	Description	Range (Modbus Value)	Default	Modbus Register read/write (I/O, Set)	Conditions for Parameters to Appear
Main Page					
	Main Page				
	Input x (1 to 3) Error				
	Alarm x (1 to 2) Condition				
	Parameter x (1 to 16) View customized parameter list.	None Input 1 [value] Input 1 Value bar [graph] Input 2 [value] Input 2 Value bar [graph] Input 3 [value] Input 3 Value bar [graph] Dgt. [digital] Diff. [differential] Value CTL SP [Differential Set Point] Set Differential Dgt. [digital] Ratio Value CTL SP [Ratio Set Point] Set Ratio Digital Set Point Remote Set Point 2 Remote Set Point 3 Target Set Point [cascade] Inner Set Point Set Point 1 Set Point 1 bar [graph] % Power 1A % Power 1B % Power 1A bar [graph] % Power 1B bar [graph] Tune Status 1 Digital Inputs	[Defaults depend on the control type selected and settings in Setup>Custom Main Page.]		

✓ **Note:** For more information about how parameter settings affect the controller's operation, see the Features Chapter.

Main Page Parameter Table

Parameter	Description	Range (Modbus Value)	Default	Modbus Register read/write (I/O, Set)	Conditions for Parameters to Appear
	<p>Go to Operations Auto-tune PID sets, edit PID parameters, select alarm set points, select PID crossover, select ramp to set point, select control set points, and mode.</p> <p>Go to Setup Set up inputs and outputs, configure the system, design the Main Page, configure alarms, configure communication, and define static messages.</p> <p>Go to Factory Set security settings, calibrate and restore factory settings, perform diagnostics, test outputs.</p>				

✓ **Note:** For more information about how parameter settings affect the controller's operation, see the Features Chapter.

Operations Page Parameters

Parameter	Description	Range (Modbus Value)	Default	Modbus Register read/write (I/O, Set)	Conditions for Parameters to Appear
Autotune PID					
Main > Operations > Autotune PID					
Channel 1 Autotune	Select which PID parameters will be automatically tuned.	Tune Off (0) PID Set 1 (1) PID Set 2 (2) PID Set 3 (3) PID Set 4 (4) PID Set 5 (5)	Tune Off (0)	305 r/w	Active if controller is in auto (closed loop) mode.
Autotune PID Type	Select which output to autotune.	Heat Only (0) Cool Only (1) Heat and Cool (3)	Off	307 r/w	Active if controller is in auto (closed-loop) mode.
Autotune PID Cascade					
Main > Operations > Autotune PID > Cascade					
Cascade Inner Loop	Select which PID parameters will be automatically tuned.	Tune Off (0) Inner Loop PID Set 1 (1) Inner Loop PID Set 2 (2) Inner Loop PID Set 3 (3) Inner Loop PID Set 4 (4) Inner Loop PID Set 5 (5)	Tune Off (0)	305 r/w	Active if Analog Input 3 Control Type is set to Cascade. Inner loop is Input Channel 1.
Cascade Outer Loop	Select which PID parameters will be automatically tuned.	Tune Off (0) Outer Loop PID Set 1 (1) Outer Loop PID Set 2 (2) Outer Loop PID Set 3 (3) Outer Loop PID Set 4 (4) Outer Loop PID Set 5 (5)	Tune Off (0)	343 r/w	Active if Analog Input 3 Control Type is set to Cascade. Outer loop is Input Channel 3.
Edit PID					
Main > Operations > Edit PID					
PID Set x (1 to 5)* (Optional Inner Loop)					
Main > Operations > Edit PID > PID Set Channel 1 > PID Set x (1 to 5)					
Proportional Band x (A or B)	Define the proportional band for PID control.	0 to 30000 0.0 to 3000.0 0.00 to 300.00 0.000 to 30.000 (0 to 30000) in integer, tenths, hundredths or thousandths	25°F 14°C	1A 1B Set 500 550 [1] 510 560 [2] 520 570 [3] 530 580 [4] 540 590 [5] r/w	Active: Always.* Based on decimal setting.

✓ **Note:** For more information about how parameter settings affect the controller's operation, see the Features Chapter.

* None of the B parameters are active if both outputs are set to cool or heat.

Operations Page Parameter Table

Parameter	Description	Range (Modbus Value)	Default	Modbus Register read/write (I/O, Set)	Conditions for Parameters to Appear
Integral x (A or B)	Set the integral time in minutes. [or]	0.00 to 99.99 minutes (0 to 9999)	0 minutes	1A 1B Set 501 551 [1] 511 561 [2] 521 571 [3] 531 581 [4] 541 591 [5] r/w	Active if PID Units (Setup Page) is set to SI and Proportional Band is not set to 0.*
Reset x (A or B)	Set the reset time in repeats per minute.	0.00 per minute to 99.99 per minute (0 to 9999)	0 per minute	1A 1B Set 502 552 [1] 512 562 [2] 522 572 [3] 532 582 [4] 542 592 [5] r/w	Active if PID Units (Setup Page) is set to U.S. and Proportional Band is not set to 0.*
Derivative x (A or B)	Set the derivative time.	0.00 to 9.99 minutes (0 to 999)	0.00 minutes	1A 1B Set 503 553 [1] 513 563 [2] 523 573 [3] 533 583 [4] 543 593 [5] r/w	Active if PID Units (Setup Page) is set to SI and Proportional Band is not set to 0.*
Rate x (A or B)	Set the rate time.	0.00 to 9.99 minutes (0 to 999)	0.00 minutes	1A 1B Set 504 554 [1] 514 564 [2] 524 574 [3] 534 584 [4] 544 594 [5] r/w	Active if PID Units (Setup Page) is set to U.S. and Proportional Band is not set to 0.*
Dead Band x (A or B)	Define the effective shift in the heating and cooling set points to prevent conflict.	0 to 30000 0.0 to 3000.0 0.00 to 300.00 0.000 to 30.000 (0 to 30000) in integer, tenths, hundredths or thousandths	0	1A 1B Set 505 555 [1] 515 565 [2] 525 575 [3] 535 585 [4] 545 595 [5] r/w	Active if Proportional Band is not set to 0 and one output is set to heat and the other to cool (Setup Page).* Based on decimal setting.
Hysteresis x (A or B)	Define the process variable change from the set point required to re-energize the output (in on-off mode).	0 to 30000 0.0 to 3000.0 0.00 to 300.00 0.000 to 30.000 (0 to 30000) in integer, tenths, hundredths or thousandths	3	1A 1B Set 507 557 [1] 517 567 [2] 527 577 [3] 537 587 [4] 547 597 [5] r/w	Active if Proportional Band is set to 0 and one output is set to heat and the other to cool (Setup Page).* Based on dial setting.

* None of the B parameters are active if both outputs are set to cool or heat.

Cascade Outer Loop PID Set x (1 to 5)

Main > Operations > Edit PID > Cascade Outer Loop PID Set X (1 to 5)

Proportional Band x (A or B)	Define the proportional band for PID control.	0 to 30000 0.0 to 3000.0 0.00 to 300.00 0.000 to 30.000 (0 to 30000) in integer, tenths, hundredths or thousandths	25°F 14°C	1A 1B Set 2600 2610 [1] 2620 2630 [2] 2640 2650 [3] 2660 2670 [4] 2680 2690 [5] r/w	Active if Control Type (Analog Input 3) is set to Cascade.*
Integral x (A or B)	Set the integral time in minutes. [or]	0.00 to 99.99 minutes (0 to 9999)	0 minutes	1A 1B Set 2601 2611 [1] 2621 2631 [2] 2641 2651 [3] 2661 2671 [4] 2681 2691 [5] r/w	Active if Control Type (Analog Input 3) is set to Cascade, PID Units (Setup Page) is set to SI and Proportional Band is not set to 0.*

✓ **Note:** For more information about how parameter settings affect the controller's operation, see the Features Chapter.

* None of the B parameters are active if both outputs are set to cool or heat.

Operations Page Parameter Table

Parameter	Description	Range (Modbus Value)	Default	Modbus Register read/write (I/O, Set)	Conditions for Parameters to Appear
Reset x (A or B)	Set the reset time in repeats per minute.	0.00 per minute to 99.99 per minute (0 to 9999)	0 per minute	1A 1B Set 2602 2612 [1] 2622 2632 [2] 2642 2652 [3] 2662 2672 [4] 2682 2692 [5] r/w	Active if Control Type (Analog Input 3) is set to Cascade, PID Units (Setup Page) is set to U.S. and Proportional Band is not set to 0.*
Derivative x (A or B)	Set the derivative time. [or]	0.00 to 9.99 minutes (0 to 999)	0.00 minutes	1A 1B Set 2603 2613 [1] 2623 2633 [2] 2643 2653 [3] 2663 2673 [4] 2683 2693 [5] r/w	Active if Control Type (Analog Input 3) is set to Cascade, PID Units (Setup Page) is set to SI and Proportional Band is not set to 0.*
Rate x (A or B)	Set the rate time.	0.00 to 9.99 minutes (0 to 999)	0.00 minutes	1A 1B Set 2604 2614 [1] 2624 2634 [2] 2644 2654 [3] 2664 2674 [4] 2684 2694 [5] r/w	Active if Control Type (Analog Input 3) is set to Cascade, PID Units (Setup Page) is set to U.S. and Proportional Band is not set to 0.*
Dead Band x (A or B)	Define the effective shift in the heating and cooling set points to prevent conflict.	0 to 30000 0.0 to 3000.0 0.00 to 300.00 0.000 to 30.000 (0 to 30000) in integer, tenths, hundredths or thousandths	0	1A 1B Set 2605 2615 [1] 2625 2635 [2] 2645 2655 [3] 2665 2675 [4] 2685 2695 [5] r/w	Active if Control Type (Analog Input 3) is set to Cascade, Proportional Band is not set to 0 and one output is set to heat and the other to cool (Setup Page).*
Hysteresis x (A or B)	Define the process variable change from the set point required to re-energize the output (in on-off mode).	0 to 30000 0.0 to 3000.0 0.00 to 300.00 0.000 to 30.000 (0 to 30000) in integer, tenths, hundredths or thousandths	3	1A 1B Set 2607 2617 [1] 2627 2637 [2] 2647 2657 [3] 2667 2677 [4] 2687 2697 [5] r/w	Active if Control Type (Analog Input 3) is set to Cascade, Proportional Band is set to 0 and one output is set to heat and the other to cool (Setup Page).*

* None of the B parameters are active if both outputs are set to cool or heat.

Alarm Set Points

Main > Operations > Alarm Set Points

Alarm x (1 or 2) Low Set Point	<per sensor> to Alarm x High Set Point	<per sensor>	302 [1] 321 [2] r/w	Active if Alarm x Type (Setup Page) is set to Process.
Alarm x (1 or 2) High Set Point	<per sensor> to Alarm x Low Set Point	<per sensor>	303 [1] 322 [2] r/w	Active if Alarm x Type (Setup Page) is set to Process.

✓ **Note:** Press the Information Key  for more task-related tips.

Operations Page Parameter Table

Parameter	Description	Range (Modbus Value)	Default	Modbus Register read/write (I/O, Set)	Conditions for Parameters to Appear
Alarm x (1 or 2) Low Deviation	Set the deviation below set point 1 that will trigger an alarm.	-19999 to -1 -1999.9 to 0.1 -199.99 to 0.01 -19.999 to 0.001 (-19999 to -1) in integer, tenths, hundredths or thousandths	-999	302 [1] 321 [2] r/w	Active if Alarm x Type (Setup Page) is set to Deviation.
Alarm x (1 or 2) High Deviation	Set the deviation above set point 1 that will trigger an alarm.	1 to 30000 0.1 to 3000.0 0.01 to 300.00 0.001 to 30.000 (1 to 30000) in integer, tenths, hundredths or thousandths	999	303 [1] 322 [2] r/w	Active if Alarm x Type (Setup Page) is set to Deviation.
Alarm x (1 or 2) Maximum Low Rate	Set the maximum rate process value per second at which alarm is triggered.	-19999 to Maximum Rate High -1 (-19999 to Maximum Rate High -1)	-100	302 [1] 321 [2] r/w	Active if Alarm x Type (Setup Page) is set to Maximum Rate.
Alarm x (1 or 2) Maximum High Rate	Set the maximum rate process value per second at which alarm is triggered.	Maximum Rate Low +1 to 30000 (Maximum Rate Low +1 to 30000)	100	303 [1] 322 [2] r/w	Active if Alarm x Type (Setup Page) is set to Maximum Rate.
PID Crossover					
Main > Operations > PID Crossover					
PID Crossover	Select what will trigger the crossover to another PID set.	Off (0) Process (1) Set Point (2)	Off	1951 r/w	Active: Always.
PID Cross	Select the value that will trigger a change in PID for sets 1 to 2, 2 to 3, 3 to 4 and 4 to 5.	-19999 to 30000 -1999.9 to 3000.0 -199.99 to 300.00 -19.999 to 30.000 (-19999 to 30000) in integer, tenths, hundredths or thousandths	Range low	1961 [1-2] 1962 [2-3] 1963 [3-4] 1964 [4-5] r/w	Appears if PID Crossover is not set to Off. Based on decimal setting.
Ramp to Set Point					
Main > Operations > Ramp to Set Point					
Ramp to Set Point Mode	Select whether the maximum rate of temperature or process value change will be limited.	Off (0) Startup (1) Startup or Change (2)	Off	1100 r/w	Active if control type is not Ratio, Differential or Remote.

✓ **Note:** For more information about how parameter settings affect the controller's operation, see the Features Chapter.

Operations Page Parameter Table

Parameter	Description	Range (Modbus Value)	Default	Modbus Register read/write (I/O, Set)	Conditions for Parameters to Appear
Ramp to Set Point Scale	Select the units of measure for ramping.	Degrees/Minute (0) Degrees/Hour (1)	Degrees/ Minute	1102 r/w	Active if Ramp to Set Point Mode is not set to Off.
Ramp to Set Point Rate	Select the maximum rate of temperature or process value change.	1 to 999 1 to 99.9 1 to 9.99 1 to 0.999 (1 to 999) in integer, tenths, hundredths or thousandths	100.0	1101 r/w	Active if Ramp to Set Point Mode is not set to Off.
Control Set Points					
Main > Operations > Control Set Points					
Boost Power (1B)	Select the minimum output 1A power that will activate output 1B (with 1.0% hysteresis).	0.0% to 100.0% (0 to 1000)	75%	883 r/w	Active if Boost Type (Setup Page > Control Output 1B) is set to Boost On Power.
Boost Delay Time (1B)	Set the time that the power level has to be exceeded before activating output 1B.	0 to 999 seconds (0 to 999)	0	884 r/w	Active if Boost Type (Setup Page > Control Output 1B) is set to Boost On Power.
Boost Set Point (1B)	Set the set point that will control output 1B.	-19999 to 30000 -1999.9 to 3000.0 -199.99 to 300.00 -19.999 to 30.000 Set Point Low Limit to Set Point High Limit [process] (-19999 to 30000) in integer, tenths, hundredths or thousandths	cool/cool Set Point High Limit (process) 999 (dev.) heat/heat Set Point Low Limit (process) -999 (dev.)	309 r/w	Active if Boost Type (Setup Page > Control Output 1B) is set to Boost On Set Point. Based on decimal setting.
Digital Set Point x (1 to 4)	Select the set point value that will be activated by digital input x. The set point name can be changed in the Setup Page.	Set Point Low Limit to Set Point High Limit		308 [1] 327 [2] 346 [3] 365 [4] r/w	Active if any digital input is set to Digital Set Point.

✓ **Note:** Press the Information Key  for more task-related tips.

Operations Page Parameter Table

Parameter	Description	Range (Modbus Value)	Default	Modbus Register read/write (I/O, Set)	Conditions for Parameters to Appear
Digital Differential Set Point x (1 to 4)	Select the differential value that will be activated by digital input x. The value will be added to the input 3 process value while digital input X is active. The set point name can be changed in the Setup Page.	-19999 to 30000 -1999.9 to 3000.0 -199.99 to 300.00 -19.999 to 30.000 (-19999 to 30000) in integer, tenths, hundredths or thousandths	0	314 [1] 333 [2] 352 [3] 371 [4] r/w	Active if any digital input is set to Digital Differential Value. Based on decimal setting.
Digital Ratio Set Point x (1 to 4)	Select the ratio value that will be activated by digital input x. The input 3 process value will be multiplied by this value while digital input x is active. The set point name can be changed in the Setup Page.	0% to 30000% (0 to 30000)	100%	315 [1] 334 [2] 353 [3] 372 [4] r/w	Active if any digital input is set to Digital Ratio Value.

Remote/Local Set Points

Main > Operations > Remote/Local Set Points

Remote/Local Set Point	Local Set Point (0) Remote 2 (1) Remote 3 (2)	Local Set Point	316 r/w	Available if Control Type (Setup Page > Analog Input 2) is set to Remote.
Switch between the remote and local set points.				

✓ **Note:** For more information about how parameter settings affect the controller's operation, see the Features Chapter.

Operations Page Parameter Record

Make a photocopy of this page and enter your settings on that copy.

Name _____

Date _____

Autotune PID

Autotune PID					
Autotune PID Type					
Autotune PID Cascade					
Cascade Inner Loop					
Cascade Outer Loop					
PID Set Channel 1					
(Optional Inner Loop)	PID Set 1	PID Set 2	PID Set 3	PID Set 4	PID Set 5
Proportional Band A					
IntegralA / ResetA					
DerivativeA / RateA					
Dead Band A					
Hysteresis A					
Proportional Band B					
IntegralB / ResetB					
DerivativeB / RateB					
Dead Band B					
Hysteresis B					
Cascade PID Set					
(Outer Loop)	PID Set 1	PID Set 2	PID Set 3	PID Set 4	PID Set 5
Proportional Band A					
IntegralA / ResetA					
DerivativeA / RateA					
Dead Band A					
Hysteresis A					
Proportional Band B					
IntegralB / ResetB					
DerivativeB / RateB					
Dead Band B					
Hysteresis B					
Alarm Set Point Menu	Alarm 1	Alarm 2			
Low Set Point					
High Set Point					
Low Deviation					
High Deviation					
Rate					
PID Crossover	PID 1 to 2	PID 2 to 3	PID 3 to 4	PID 4 to 5	
PID Cross					
Ramp x to Set Point					
Ramp to Set Point Mode					
Ramp to Set Point Rate					
Ramp to Set Point Scale					
Control Set Points					
Boost Power					
Boost Delay Time					
Remote/Local Set Point					
Boost Set Point					
	Dig. SP 1	Dig. SP 2	Dig. SP 3	Dig. SP 4	
Digital Set Point x (1 to 4)					
Digital Differential Set Point x (1 to 4)					
Digital Ratio Set Point x (1 to 4)					

Setup Page Parameters

Parameter	Description	Range (Modbus Value)	Default	Modbus Register read/write (I/O, Set)	Conditions for Parameters to Appear
System					
Main > Setup > System					
PID Units	Choose units for PID control.	US (US will be in Reset/Rate) (0) SI (SI will be in Integral/Derivative) (1)	US (0)	900 r/w	Active: Always.
°F or °C	Choose temperature scale.	°F (0) °C (1)	°F (0)	901 r/w	Active: Always.
Show °F or °C	Choose whether to display or hide °C or °F in top display.	No, Upper Display (0) Yes, Upper Display (1)	Yes, Upper Display (1)	1923 r/w	Active if input type is either RTD or thermocouple.
Maximum Transfer Heat	The maximum heat output power when control is switched from auto to manual mode.	0.0% to 100.0% (0 to 1000) in tenths	100.0% (1000)	452 r/w	Active if one or both control outputs is set to heat [reverse].
Maximum Transfer Cool	The maximum cool output power when control is switched from auto to manual mode.	-100.0% to 0.0% (-1000 to 0) in tenths	-100.0% (-1000)	453 r/w	Active if one or both control outputs is set to cool [direct].
Manual to Auto Transfer	Select how the set point will be determined when control switches from manual to auto mode.	Restore Set Point (0) Reverse Bumpless (1)	Restore Set Point (0)	454 r/w	Active: Always.
Autotune Set Point	Set percent of set point to auto-tune to.	50 to 150% (50 to 150)	90% (90)	304 r/w	Active: Always.
Failure Mode	Select how the outputs will behave if an input error switches the controller to manual mode.	Bumpless Transfer (0) Fixed (1)	Bumpless (0)	880 r/w	Active: Always.

✓ **Note:** For more information about how parameter settings affect the controller's operation, see the Features Chapter.

Setup Page Parameter Table

Parameter	Description	Range (Modbus Value)	Default	Modbus Register read/write (I/O, Set)	Conditions for Parameters to Appear
Input 1 Fail	Select the output power to be maintained if an input error switches control to manual mode.	0.0% to High Power Limit [heat only or cool only] Cool High Power Limit to Heat High Power Limit [heat/cool or cool/heat] in tenths	0.0% (0)	903 r/w	Active if Failure Mode is set to Fixed.
Open Loop Detect	Select whether to turn off outputs and display an error message.	Off (0) On (1)	Off (0)	904 r/w	Active: Always.
Analog Input x (1 to 3)					
Main > Setup > Analog Input x (1 to 3) Inputs 2 and 3 appear only if the controller is the enhanced version (F4P _ - _ _ AB - _ _ _ _).					
Sensor	Select the sensor.	Thermocouple (0) RTD (1) Process (2) Slidewire (3) [Analog Input 3 only] Off (4) [Analog Inputs 2 and 3 only]	Thermocouple (0)	Input 600 [1] 610 [2] 620 [3] r/w	Inputs 2 and 3 appear only if the controller is the enhanced version (F4P _ - _ _ AB - _ _ _ _). Active: Always.
Type	Select the linearization table to apply to the sensor.	If Sensor is set to thermocouple: J (0) K (1) T (2) E (3) N (4) C (5) D (6) PT2 (7) R (8) S (9) B (10) If Sensor is set to RTD: 100Ω DIN (11) 100Ω JIS (12) 500Ω DIN (23) 500Ω JIS (24) 1kΩ DIN (25) 1kΩ JIS (26) If Sensor is set to Process: 4 to 20mA (13) 0 to 20mA (14) 0 to 5V (15) 1 to 5V (16) 0 to 10V (17) 0 to 50mV (18)	J (0)	Input 601 [1] 611 [2] 621 [3] r/w	Active if Sensor is not set to Off. Inputs 2 and 3 appear only if the controller is the enhanced version (F4P _ - _ _ AB - _ _ _ _). The selection that appears will depend on which sensor was selected for the previous parameter.

✓ **Note:** Press the Information Key **i** for more task-related tips.

*The tenth digit of your model number, F4PX-XXXX-XXXX, determines what RTD resistance values the unit uses. Refer to the Ordering Information in the Appendix.

Setup Page Parameter Table

Parameter	Description	Range (Modbus Value)	Default	Modbus Register read/write (I/O, Set)	Conditions for Parameters to Appear
Analog Input 2					
Main > Setup > Analog Input 2 Inputs 2 and 3 appear only if the controller is the enhanced version (F4P _ - _ _ AB - _ _ _ _).					
Control Type Select the control type.	Normal (0) Remote (3) Alternate (4)	Normal	1140	r/w	Appears if the controller is the enhanced version (F4P_ - _ _ AB- _ _ _ _), Analog Input 2 is selected and Analog Input 3 is set to Normal Control.
Analog Input x (1 to 3) continued					
Main > Setup > Analog Input x (1 to 3) Inputs 2 and 3 appear only if the controller is the enhanced version (F4P _ - _ _ AB - _ _ _ _).					
Units Name the units of measure for the input.	Temperature (0) Units (1) [3 characters]	Temperature (0)	Input 608 [1] 3070 char 1 3071 char 2 3072 char 3 618 [2] 3073 char 1 3074 char 2 3075 char 3 628 [3] 3076 char 1 3077 char 2 3078 char 3 r/w		Inputs 2 and 3 appear only if the controller is the enhanced version (F4P _ - _ _ AB - _ _ _ _). Active if Sensor is set to Process.
Decimal Set the decimal point for input.	0 (0) 0.0 (1) 0.00 [process] (2) 0.000 [process] (3)	0	Input 606 [1] 616 [2] 626 [3] r/w		Inputs 2 and 3 appear only if the controller is the enhanced version (F4P _ - _ _ AB - _ _ _ _). Active: Always.
Scale Low Set unit value for low end of current or voltage range.	Depends on sensor and decimal point selection. (max. range -19999 to 30000, process)	—	Input 680 [1] 682 [2] 684 [3] r/w		Inputs 2 and 3 appear only if the controller is the enhanced version (F4P _ - _ _ AB - _ _ _ _). Active if Sensor is set to Process.
Scale High Set unit value for high end of current or voltage range.	Depends on sensor and decimal point selection. (max. range -19999 to 30000, process)	—	Input 681 [1] 683 [2] 685 [3] r/w		Inputs 2 and 3 appear only if the controller is the enhanced version (F4P _ - _ _ AB - _ _ _ _). Active if Sensor is set to Process.
Scaling Set the process input scaling relationship.	Normal Scaling (0) Scale Inversion (1)	0	Input 693 [1] 694 [2] 695 [3] r/w		Inputs 2 and 3 appear only if the controller is the enhanced version (F4P _ - _ _ AB - _ _ _ _). Active if Sensor is set to Process.
Set Point Low Limit * Set limit for minimum set point.	Depends on sensor and decimal point selection. (max. range process 19999 to 30000)	—	Input 602 [1] 612 [2] 622 [3] r/w		Inputs 2 and 3 appear only if the controller is the enhanced version (F4P _ - _ _ AB - _ _ _ _). Active: Always.
Set Point High Limit * Set limit for maximum set point.	Depends on sensor and decimal point selection. (max. range process 19999 to 30000)	—	Input 603 [1] 613 [2] 623 [3] r/w		Inputs 2 and 3 appear only if the controller is the enhanced version (F4P _ - _ _ AB - _ _ _ _). Active: Always.

✓ **Note:** For more information about how parameter settings affect the controller's operation, see the Features Chapter.

*Not functional if analog input 3 setup for cascade.

**Scale Low value must be less than Scale High value for Normal or Inverse Scaling.

Setup Page Parameter Table

Parameter	Description	Range (Modbus Value)	Default	Modbus Register read/write (I/O, Set)	Conditions for Parameters to Appear
Offset Type	Select whether to use one or 10 input offset points.	Single Linear (0) Multiple Point (1)	Single Linear (0)	Input 5572 [1] 5573 [2] 5574 [3] r/w	Inputs 2 and 3 appear only if the controller is the enhanced version (F4P _ - _ _ AB - _ _ _ _).
Calibration Offset Value	Select the input offset value.	Set Point Low Limit to Set Point High Limit (max. range process 19999 to 30000)	—	Input 605 [1] 615 [2] 625 [3] r/w	Inputs 2 and 3 appear only if the controller is the enhanced version (F4P _ - _ _ AB - _ _ _ _). Active if Offset Type is set to Single Linear.
Clear Input x (1 to 3) Offsets	Reset offset values to 0.	No (0) Yes (1)	No (0)	Input 5566 [1] 5567 [2] 5568 [3] r/w	Inputs 2 and 3 appear only if the controller is the enhanced version (F4P _ - _ _ AB - _ _ _ _). Active if Offset Type is set to Multiple Point.
Offset Point Input 1 (Set 1 to 10)	Set the temperature or value that will trigger the offset.	-19999 or Input Offset (x-1) Value + 1 to Input Offset (x+1) Value - 1 or 30000.	SP Low + ((SP High- SP Low) * (x-1) /9)	5506 [1] 5507 [2] 5508 [3] 5509 [4] 5510 [5] 5511 [6] 5512 [7] 5513 [8] 5514 [9] 5515 [10] r/w	Active if offset type is multiple point.
Offset Point Input 2 (Set 1 to 10)	Set the temperature or value that will trigger the offset.	-19999 or Input Offset (x-1) Value + 1 to Input Offset (x+1) Value - 1 or 30000.	SP Low + ((SP High- SP Low) * (x-1) /9)	5516 [1] 5517 [2] 5518 [3] 5519 [4] 5520 [5] 5521 [6] 5522 [7] 5523 [8] 5524 [9] 5525 [10] r/w	Input 2 appears only if the controller is the enhanced version (F4P _ - _ _ AB - _ _ _ _). Active if offset type is multiple point.
Offset Point Input 3 (Set 1 to 10)	Set the temperature or value that will trigger the offset.	-19999 or Input Offset (x-1) Value + 1 to Input Offset (x+1) Value - 1 or 30000.	SP Low + ((SP High- SP Low) * (x-1) /9)	5526 [1] 5527 [2] 5528 [3] 5529 [4] 5530 [5] 5531 [6] 5532 [7] 5533 [8] 5534 [9] 5535 [10] r/w	Input 3 appears only if the controller is the enhanced version (F4P _ - _ _ AB - _ _ _ _). Active if offset type is multiple point.
Offset Value Input 1 (Set 1 to 10)	Set the size of the offset.	-1000 to 1000 (-1000 to 1000)	0 (0)	5536 [1] 5537 [2] 5538 [3] 5539 [4] 5540 [5] 5541 [6] 5542 [7] 5543 [8] 5544 [9] 5545 [10] r/w	Active if offset type is multiple point.

✓ **Note:** Press the Information Key  for more task-related tips.

Setup Page Parameter Table

Parameter	Description	Range (Modbus Value)	Default	Modbus Register read/write (I/O, Set)	Conditions for Parameters to Appear
Offset Value Input 2 (Set 1 to 10)	Set the size of the offset.	-1000 to 1000 (-1000 to 1000)	0 (0)	5546 [1] 5547 [2] 5548 [3] 5549 [4] 5550 [5] 5551 [6] 5552 [7] 5553 [8] 5554 [9] 5555 [10] r/w	Input 2 appears only if the controller is the enhanced version (F4P_ - _ _ AB - _ _ _ _). Active if offset type is multiple point.
Offset Value Input 3 (Set 1 to 10)	Set the size of the offset.	-1000 to 1000 (-1000 to 1000)	0 (0)	5556 [1] 5557 [2] 5558 [3] 5559 [4] 5560 [5] 5561 [6] 5562 [7] 5563 [8] 5564 [9] 5565 [10] r/w	Input 2 appears only if the controller is the enhanced version (F4P_ - _ _ AB - _ _ _ _). Active if offset type is multiple point.
Filter Time	Set the filter time for input in seconds.	-60.0 to 60.0 (-600 to 600) in tenths	0 (0) 1.0 if Decimal set to 0.0 and Sensor Type set to Thermocouple or RTD. (10)	604 [1] 614 [2] 624 [3] r/w	Inputs 2 and 3 appear only if the controller is the enhanced version (F4P_ - _ _ AB - _ _ _ _). Active: Always.
Error Latch	Select whether error clear is automatic or manual.	Self Clear (0) Latch (1)	Self Clear (0)	607 [1] 617 [2] 627 [3] r/w	Inputs 2 and 3 appear only if the controller is the enhanced version (F4P_ - _ _ AB - _ _ _ _). Active: Always.
Square Root	Apply square-root extraction to input.	Off (0) On (1)	Off (0)	5569 [1] 5570 [2] 5571 [3] r/w	Inputs 2 and 3 appear only if the controller is the enhanced version (F4P_ - _ _ AB - _ _ _ _). Active if Sensor is set to Process.

Analog Input 3

Main > Setup > Analog Input 3

Auto/Manual Slidewire Calibration	Select the slidewire calibration method.	Skip Calibration (0) Automatic (1) Manual (2)	Skip Calibration (0)	1915 r/w	Appears if the controller is the enhanced version (F4P_ - _ _ AB- _ _ _ _), Analog Input 3 is selected and Sensor is set to Slidewire.
Slidewire Learn Closed	Calibrate the slidewire to the closed valve.	Learn (1)	—	1918 w	Appears if the controller is the enhanced version (F4P_ - _ _ AB- _ _ _ _), Analog Input 3 is selected, Sensor is set to Slidewire and Auto/Manual Calibration is set to Manual.

✓ **Note:** For more information about how parameter settings affect the controller's operation, see the Features Chapter.

Setup Page Parameter Table

Parameter	Description	Range (Modbus Value)	Default	Modbus Register read/write (I/O, Set)	Conditions for Parameters to Appear
Slidewire Learn Open	Calibrate the slidewire to the open valve.	Learn (1)	—	1919 w	Appears if the controller is the enhanced version (F4P_ - __ AB- ____), Analog Input 3 is selected, Sensor is set to Slidewire and Auto/Manual Calibration is set to Manual.
Slidewire Deadband	Select the slidewire deadband.	0.3% to 100.0% (3 to 1000) in tenths	1%	1916 r/w	Appears if the controller is the enhanced version (F4P_ - __ AB- ____), Analog Input 3 is selected and Sensor is set to Slidewire.
Slidewire Hysteresis	Select the slidewire hysteresis.	0.0% to 100.0% (0 to 1000) in tenths	0.0%	1917 r/w	Appears if the controller is the enhanced version (F4P_ - __ AB- ____), Analog Input 3 is selected and Sensor is set to Slidewire.
Control Type	Select the control type.	Normal (0) Ratio (1) Differential (2) Remote (3) Cascade (5)	Normal	1141 r/w	Appears if the controller is the enhanced version (F4P_ - __ AB- ____) and Analog Input 2 or 3 is selected.
Cascade	Select the cascade control method.	Process Cascade (0) Deviation Cascade (1)	Process Cascade	1925 r/w	Appears if the controller is the enhanced version (F4P_ - __ AB- ____), Analog Input 3 is selected and Cascade is selected as the control type.
Cascade Low Range, Process	Select the cascade low range.	<sensor range> (max. range process 19999 to 30000)	<sensor range low>	1926 r/w	Appears if the controller is the enhanced version (F4P_ - __ AB- ____) and Cascade is set to Process Cascade.
Cascade High Range, Process	Select the cascade high range.	<sensor range> (max. range process 19999 to 30000)	<sensor range high>	1927 r/w	Appears if the controller is the enhanced version (F4P_ - __ AB- ____) and Cascade is set to Process Cascade.
Cascade Low Deviation Range	Select the cascade low deviation.	-19999 to -1 -1999.9 to -0.1 -199.99 to -0.01 -19.999 to -0.001 (-19999 to 1) in integer, tenths, hundredths, thousandths	-19999	1926 r/w	Appears if the controller is the enhanced version (F4P_ - __ AB- ____) and Cascade is set to Deviation Cascade. Based on decimal setting.
Cascade High Deviation Range	Select the cascade high deviation.	1 to 9999 1 to 999.9 1 to 99.99 1 to 9.999 (1 to 9999) in integer, tenths, hundredths, thousandths	9999	1927 r/w	Appears if the controller is the enhanced version (F4P_ - __ AB- ____) and Cascade is set to Deviation Cascade. Based on decimal setting.

✓ **Note:** Press the Information Key  for more task-related tips.

Setup Page Parameter Table

Parameter	Description	Range (Modbus Value)	Default	Modbus Register read/write (I/O, Set)	Conditions for Parameters to Appear
Digital Input x (1 to 4)					
Main > Setup > Digital Input x (1 to 4)					
Function		Off (0)	Off	Input	Active: Always.
Select the digital input function.	Panel Lock (1) [level]	Reset Alarm 1 (2) [edge]		1060 [1]	Only the currently active features will appear in the list.
Level detect requires continuous contact switch.	Reset Alarm 2 (3) [edge]	Reset Both Alarms (4) [edge]		1062 [2]	
Edge detect requires mounting contact switch.	Control Outputs Off (5) [level]	Digital Set Point (6) [level]		1064 [3]	
	Digital Differential Value (7) [level]	Digital Ratio Value (8) [level]		1066 [4]	
	Remote [set point analog input] 2 (9) [level]	Remote [set point analog input] 3 (10) [level]		r/w	
	Alternate Control (11) [level]	Manual Control (12) [level]			
	Reverse Outputs (13) [level]	Activate Message (14) [edge]			
	Auto/Manual Key Lock (15) [level]	Switch PID Sets 1-5 (16) [level]			
Name		<7 characters selected by user>		ASCII Digital Storage Input	
Name the digital set point, digital ratio value or digital differential value for easy reference.	Name Digital SP (0)	Name Digital SP (1)	DGT SP1	3000-3006 [1]	
	Name Digital SP (2)	Name Digital SP (3)	DGT SP2	3010-3016 [2]	
			DGT SP3	3020-3026 [3]	
			DGT SP4	3030-3036 [4]	
				r/w	
Activate Message		Message1_Name (0)	Message 1 Name	Digital Input	Active if Function is set to Activate Message. (See Main > Setup > Static Message.)
Select which static message to display.	Message2_Name (1)	Message3_Name (2)		3050 [1]	
	Message4_Name (3)			3051 [2]	
				3052 [3]	
				3053 [4]	
				r/w	
Message Display Time		0 to 999 (0 to 999)	10 seconds	Digital Input	Active if Function is set to Activate Message.
Set the length of time that the message will display.				3060 [1]	
				3061 [2]	
				3062 [3]	
				3063 [4]	
				r/w	

✓ **Note:** For more information about how parameter settings affect the controller's operation, see the Features Chapter.

Setup Page Parameter Table

Parameter	Description	Range (Modbus Value)	Default	Modbus Register read/write (I/O, Set)	Conditions for Parameters to Appear
Condition*	Select the condition to trigger digital input.	Low (0) High (1)	Low	Input 1061 [1] 1063 [2] 1065 [3] 1067 [4] r/w	Active: Always.
Control Output x (1A and 1B)					
Main > Setup > Control Output x (1A and 1B)					
Function	Select type of function for output.	Off (0) [1B only] Heat (1) [reverse] Cool (2) [direct]	Heat (1A) Off (1B)	Output 700 [1A] 717 [1B] r/w	Active: Always.
Cycle Time Type	Select the time base.	Variable Burst (0) Fixed Time (1)	Fixed Time	Output 509 [1A] 559 [1B] r/w	Active if output x is not a mechanical relay or process output.
Cycle Time Value	Select the cycle time period.	0.1 to 60 seconds (1 to 600) in tenths	1 second	Output 506 [1A] 556 [1B]	Active if Cycle Time Type is set to Fixed Time.
Process	Set process output type.	4 to 20mA (0) 0 to 20mA (1) 0 to 5V (2) 1 to 5V (3) 0 to 10V (4) 20 to 4mA (5) [reverse value]	4 to 20mA	Output 701 [1A] 718 [1B] r/w	Active if the controller is equipped with a process output.
Duplex (1A)	Control both heat and cool from one output.	Off (0) On (1)	Off	844 r/w	Active if output 1A is a process output.
High Power Limit	Set high limit control (PID mode only) output power level.	Low Limit +1 to 100% ()	100%	Output 714 [1A] 731 [1B] r/w	Active: Always.
Low Power Limit	Set low limit control (PID mode only) output power level.	0% to High Limit -1 ()	0%	Output 715 [1A] 732 [1B] r/w	Active: Always.
Boost Type (1B)	Select what will activate control output 1B.	Boost on Power (0) Boost on Set Point (1)	Power	885 r/w	Active if the control output functions are both set to heat or cool.
Boost Power Mode (1B)	Select whether boost power operates in Manual Mode.	Auto Only (0) Auto/Manual (1)	Boost Auto	881 r/w	Active if Boost Type is set to Power.
Boost Set Point Type (1B)	Select which type of set point will control output 1B.	Process (0) Deviation (1)	Process	882 r/w	Active if Boost Type is set to Set Point.

* **Note:** Digital inputs are edge triggered and require a transition from a high to low or low to high state.

✓ **Note:** Press the Information Key  for more task-related tips.

Setup Page Parameter Table

Parameter	Description	Range (Modbus Value)	Default	Modbus Register read/write (I/O, Set)	Conditions for Parameters to Appear
Alarm Output x (1 and 2)					
Main > Setup > Alarm Output x (1 and 2)					
Name	Name the alarm for easy reference.	<10 characters selected by user>	ALARMX	3200-3209 [1] 3210-3219 [2] r/w	Active: Always.
Alarm Type	Select the alarm type.	Off (0) Process (1) Deviation (2) Maximum Rate (3)	Off (0)	Output 702 [1] 719 [2] r/w	Active: Always.
Alarm Source	Select the alarm source.	Input 1 (0) Input 2 (1) Input 3 (2)	Input 1 (0)	Output 716 [1] 733 [2] r/w	Active if the source is enabled. Inputs 2 and 3 appear only if the controller is the enhanced version (F4P _ - _ _ AB - _ _ _ _)
Latching	Choose automatic or manual clearing of alarms.	Alarm Self-Clears (0) Alarm Latches (1)	Alarm Self-Clears (0)	Output 704 [1] 721 [2] r/w	Active if Alarm Output is enabled.
Silencing	Choose whether to mask alarms on power-up.	No (0) Yes (1)	No (0)	Output 705 [1] 722 [2] r/w	Active if Alarm Output is enabled.
Alarm Hysteresis	Set the alarm hysteresis.	1 to 30000 0.1 to 30000 0.01 to 30000 0.001 to 30000 (1 to 30000) in integer, tenths, hundredths, thousandths	3	Output 703 [1] 720 [2] r/w	Active if Alarm Output is enabled. Based on decimal setting.
Alarm Sides	Choose to enable Low, High or both alarm set points.	Both (0) Low (1) High (2)	Both (0)	Output 706 [1] 723 [2] r/w	Active if Alarm Output is enabled.
Alarm Logic	Select the alarm logic option.	Open on Alarm (0) Close on Alarm (1)	Open on Alarm (0)	Output 707 [1] 724 [2] r/w	Active if Alarm Output is enabled.
Alarm Messages	Select the alarm message option.	Yes on Main Page (0) No (1)	Yes on Main Page (0)	Output 708 [1] 725 [2] r/w	Active if Alarm Output is enabled.

✓ **Note:** For more information about how parameter settings affect the controller's operation, see the Features Chapter.

Setup Page Parameter Table

Parameter	Description	Range (Modbus Value)	Default	Modbus Register read/write (I/O, Set)	Conditions for Parameters to Appear
Retransmit Output x (1 and 2)					
Main > Setup > Retransmit Output x (1 and 2)					
Retransmit Source *	Choose a source for retransmit signal.	Off (0) Input 1 (1) Input 2 * (2) Input 3 * (3) Set Point 1 (4) Channel 1 Power (5)	Input 1 (1)	Output 709 [1] 726 [2] r/w	Active: Always. (Values appear only if the source is enabled.)
Analog Range	Select voltage or current range to retransmit.	4 to 20mA (0) 0 to 20mA (1) 0 to 5V (2) 1 to 5V (3) 0 to 10V (4)	4 to 20mA (0)	Output 836 [1] 837 [2] r/w	Active if Retransmit source is not set to Off.
Low Scale	Set low end of current or voltage range to retransmit.	-19999 to 30000 (minimum sensor range)	Low end of sensor range	Output 710 [1] 727 [2] r/w	Active if Retransmit source is not set to Off. Based on decimal setting and source setting.
High Scale	Set high end of current or voltage range to retransmit.	-19999 to 30000 (maximum sensor range)	High end of sensor range	Output 711 [1] 728 [2] r/w	Active if Retransmit source is not set to Off. Based on decimal setting and source setting.
Scale Offset	Shift the scale up (+) or down (-) to agree with source signal.	-9999 to 9999 Range Low to Range High (-19999 to 30000)	0	Output 712 [1] 729 [2] r/w	Active if Retransmit source is not set to Off. Based on decimal setting and source setting.

Communications

Main > Setup > **Communications**

Baud Rate	Select transmission speed.	19200 (0) 9600 (1)	19200 (0)	Not available	Active: Always.
Address	Select address for controller.	1 to 247	1	Not available	Active: Always.

✓ **Note:** Press the Information Key  for more task-related tips.

* Inputs 2 and 3 only available if unit has the Enhanced Control Operation option. *The eighth digit of your model number, F4PX-XXXX-XXXX, determines the Control Operation. Refer to the Ordering Information in the Appendix.*

Setup Page Parameter Table

Parameter	Description	Range (Modbus Value)	Default	Modbus Register read/write (I/O, Set)	Conditions for Parameters to Appear
Custom Main Page					
Main > Setup > Custom Main Page					
Parameter x (1 to 16)	None (0)		[Defaults de-	Par.	Appears: Always.
Choose parameters to appear on the Main Page.	Input 1 [value] (1)		pend on the	1400 [1]	Analog Inputs 2 and 3 appear only if the controller is the enhanced version (F4P_ - _ _ AB- _ _ _ _).
	Input 1 Value bar [graph] (2)		control type	1401 [2]	The range of selections for the Custom Main Page will depend on other parameter settings.
	Input 2 [value] (3)		selected.]	1402 [3]	
	Input 2 Value bar [graph] (4)			1403 [4]	
	Input 3 [value] (5)			1404 [5]	
	Input 3 Value bar [graph] (6)			1405 [6]	
	*Dgt. [digital] Diff. [differential] Value (8)			1406 [7]	
	*CTL SP [Differential Set Point] (9)			1407 [8]	
	*Set Differential (10)			1408 [9]	
	**Dgt. [digital] Ratio Value (11)			1409 [10]	
	**CTL SP [Ratio Set Point] (12)			1410 [11]	
	**Set Ratio (13)			1411 [12]	
	Digital Set Point (7)			1412 [13]	
	Remote Set Point 2 (14)			1413 [14]	
	Remote Set Point 3 (15)			1414 [15]	
	Target Set point (16)			1415 [16]	
	[cascade] Inner Set Point (17)			r/w	
	Set Point 1 (18)				
	Set Point 1 bar [graph] (19)				
	% Power 1A (20)				
	% Power 1B (21)				
	% Power 1A bar [graph] (22)				
	% Power 1B bar [graph] (23)				
	Tune Status 1 (24)				
	***Digital Inputs (25)				
	Active Ch1 PID Set (26)				

✓ **Note:** For more information about how parameter settings affect the controller's operation, see the Features Chapter.

Setup Page Parameter Table

Parameter	Description	Range (Modbus Value)	Default	Modbus Register read/write (I/O, Set)	Conditions for Parameters to Appear
Process Display					
Main > Setup > Process Display					
Process Display	Select how the upper display will function.	Input 1 (0) Alternating (1)	Input 1 (0)	1910 r/w	Appears only if the controller is the enhanced version (F4P_ - _ _ AB- _ _ _ _).
Display Time	Select the time, in seconds, that each input will appear in the upper display.	0 to 999 seconds (0 to 999)	2 seconds	Input 1911 [1] 1912 [2] 1913 [3] r/w	Appears only if the controller is the enhanced version (F4P_ - _ _ AB- _ _ _ _) and Process Display is set to Alternating.
LED Intensity	Set the brightness level of the upper display.	0 to 15 can be set (0 to 15)	8	1914 r/w	Appears only if the controller is the enhanced version (F4P_ - _ _ AB- _ _ _ _) and Process Display is set to Alternating.
Static Message					
Main > Setup > Static Message					
Message x (1 to 4)	Enter or change messages that can be displayed by activating a digital input.	4 lines of 17 characters each The first line serves as the message name.	Message x Name Message x Line 1 Message x Line 2 Message x Line 3	ASCII Storage mess. 4501-4517 [1] 4521-4537 [1] 4541-4557 [1] 4561-4577 [1] 4581-4597 [2] 4601-4617 [2] 4621-4637 [2] 4641-4657 [2] 4661-4677 [3] 4681-4697 [3] 4701-4717 [3] 4721-4737 [3] 4741-4757 [4] 4761-4777 [4] 4781-4797 [4] 4801-4817 [4] r/w	Active: Always.

✓ **Note:** Press the Information Key  for more task-related tips.

Setup Page Parameter Record

Make a photocopy of this page and enter your settings on that copy.

Name _____ Date _____

System	Setting									
PID Units										
°F or °C										
Show °F or °C										
Maximum Transfer Heat										
Maximum Transfer Cool										
Manual to Auto Transfer										
Autotune Set Point										
Failure Mode										
Input 1 Fail										
Open Loop Detect										
Analog Input	In 1	In 2	In 3							
Sensor										
Type										
Control Type										
Units Name										
Decimal										
Scale Low										
Scale High										
Scaling										
Set Point Low Limit										
Set Point High Limit										
Offset Type										
Input Offsets	In Off 1	In Off 2	In Off 3	In Off 4	In Off 5	In Off 6	In Off 7	In Off 8	In Off 9	In Off 10
Clear Input Offsets										
Offset Point										
Calibration Offset Value										
Filter Time										
Error Latch										
Square Root										
Auto/Manual Slidewire Cali.										
Slidewire Deadband										
Slidewire Hysteresis										
Control Type										
Cascade										
Cascade Low Range										
Cascade High Range										
Cascade Low Deviation										
Cascade High Deviation										
Digital Input	Digital In 1	Digital In 2	Digital In 3	Digital In 4						
Function										
Name										
Activate Message										
Message Display Time										
Condition										

Control Output	Output 1A	Output 1B
Function		
Cycle Time Type		
Cycle Time Value		
Process		
Duplex (1A)		
High Power Limit		
Low Power Limit		
Boost Type (1B)		
Boost Power Mode (1B)		
Boost Set Point Type (1B)		
Alarm Output	Alarm 1	Alarm 2
Name		
Alarm Type		
Alarm Source		
Latching		
Silencing		
Alarm Hysteresis		
Alarm Sides		
Alarm Logic		
Alarm Messages		
Retransmit Output	Retrans 1	Retrans 2
Retransmit Source		
Analog Range		
Low Scale		
High Scale		
Scale Offset		
Communications	Setting	
Baud Rate		
Address		
Custom Main Page (see Custom Main Page Parameter Record)		
Process Display		
Display Time		
LED Intensity		
Static Message		
Message 1, Line 1		
Message 1, Line 2		
Message 1, Line 3		
Message 1, Line 4		
Message 2, Line 1		
Message 2, Line 2		
Message 2, Line 3		
Message 2, Line 4		
Message 3, Line 1		
Message 3, Line 2		
Message 3, Line 3		
Message 3, Line 4		
Message 4, Line 1		
Message 4, Line 2		
Message 4, Line 3		
Message 4, Line 4		

Custom Main Page Parameter Record

Make a photocopy of this page and enter your settings on that copy.

Name _____ Date _____

Will always appear if active:	Main Page Input 1 Error Input 2 Error Input 3 Error	
Will appear if active and set up to appear:	Alarm 1 Condition Alarm 2 Condition Autotuning (Position on Main Page)	(Possible parameters)
Choose from the column at the far right the information you want to appear on the Main Page (in any order):	P1 _____ P2 _____ P3 _____ P4 _____ P5 _____ P6 _____ P7 _____ P8 _____ P9 _____ P10 _____ P11 _____ P12 _____ P13 _____ P14 _____ P15 _____ P16 _____	None Input 1 [value] Input 1 Value bar [graph] Input 2 [value] Input 2 Value bar [graph] Input 3 [value] Input 3 Value bar [graph] Dgt [digital] Ratio Value * Ratio Set Point * Set Ratio * Dgt [digital] Diff. [differential] Value ** Diff [differential] Set Point** Set Differential ** Digital Set Point Remote Set Point 2 Remote Set Point 3 Target Set point [cascade] Inner Set Point Set Point 1 Set Point 1 bar [graph] % Power 1A % Power 1B % Power 1A bar [graph] % Power 1B bar [graph] Tune Status 1 Digital Inputs Active Ch1 PID Set * appears if Input 3 is set to Ratio ** appears if Input 3 is set to Differential
Will always appear:	Go to Operations Go to Setup Go to Factory	

Factory Page Parameters

Parameter	Description	Range (Modbus Value)	Default	Modbus Register read/write (I/O, Set)	Conditions for Parameters to Appear
Set Lockout					
Main > Factory > Set Lockout					
Set Point	Set the set point access level.	Full Access (0) Read Only (1)	Full Access (0)	1300 r/w	Active: Always.
Operations, Autotune PID	Set access to this menu.	Full Access (0) Read Only (1) Password (2) Hidden (3)	Full Access (0)	1306 r/w	Active: Always.
Operations, Edit PID	Set access to this menu.	Full Access (0) Read Only (1) Password (2) Hidden (3)	Full Access (0)	1307 r/w	Active: Always.
Operations, Alarm Set Point	Set access to this menu.	Full Access (0) Read Only (1) Password (2) Hidden (3)	Full Access (0)	1308 r/w	Active: Always.
Setup Page	Set access to this page.	Full Access (0) Read Only (1) Password (2) Hidden (3)	Full Access (0)	1302r/w	Active: Always.
Factory Page	Set access to this page.	Full Access (0) Read Only (1) Password (2)	Full Access (0)	1303 r/w	Active: Always.
Set/Change Password	Reset or change password. Choose Yes to change the password.	4 characters	none	1330 [1] 1331 [2] 1332 [3] 1333 [4] r/w	Active: Always.
Clear Locks	Unlock set point and all pages and menus.	Yes (0)		1315 r/w	Active: Always.

✓ **Note:** For more information about how parameter settings affect the controller's operation, see the Features Chapter.

Factory Page Parameter Table

Parameter	Description	Range (Modbus Value)	Default	Modbus Register read/write (I/O, Set)	Conditions for Parameters to Appear
Operations, PID Crossover	Set access to PID Crossover.	Full Access (0) Read Only (1) Password (2) Hidden (3)	Full Access (0)	1316 r/w	Active: Always.
Operations, Ramp Set Point	Set access to the Ramp Set Point.	Full Access (0) Read Only (1) Password (2) Hidden (3)	Full Access (0)	1317 r/w	Active: Always.
Operations, Control Set Point	Set access to the Control Set Point.	Full Access (0) Read Only (1) Password (2) Hidden (3)	Full Access (0)	1318 r/w	Active if any Digital Input is set to Digital Set Point.
Operations, Remote/Local Set Point	Set access to the Remote/Local Set Point.	Full Access (0) Read Only (1) Password (2) Hidden (3)	Full Access (0)	1319 r/w	Available if Control Type (Setup Page > Analog Input 2 or 3) is set to Remote.

Diagnostic

Main > Factory > Diagnostic

Model	First Digits	P4 (4P) ASCII 5280 Dec	P4 (4P) ASCII 5280 Dec	0 r	Active: Always.
Manufactured Date	Identifies the manufacture date. (WWYY) Week:Year	0100 to 5200 (0100 to 5200)		5 r	Active: Always.
Serial Number	Identifies the individual controller.	000000 to 999999 (0 to 999999)		1 [1st part] 2 [2nd part] r	Active: Always.
Software Number	Identifies the software ID number.	00 to 99 (0 to 99)		3 r	Active: Always.
Software Revision	Identifies the software revision.	0.00 to 9.99 (0 to 999)		4 r	Active: Always.
Input 1	Displays the input 1 type.	Univ Single (7)		8 r	Active: Always.

✓ **Note:** For more information about how parameter settings affect the controller's operation, see the Features Chapter.

Factory Page Parameter Table

Parameter	Description	Range (Modbus Value)	Default	Modbus Register read/write (I/O, Set)	Conditions for Parameters to Appear
Input 2	Displays the input 2 type.	Univ Dual (8) None (0)		9 r	Active: Always.
Input 3	Displays the input 3 type.	Univ Dual (8) None (0)		10 r	Active: Always.
Output x (1A or 1B)	Displays the output type.	None (0) [Out 1B only] Mechanical Relay (1) SSR (2) DC (3) Process (4)		Output 16 [1A] 17 [1B] r	Active: Always.
Retransmit x (1 or 2)	Displays the retransmit option.	None (0) Process (4)		Retransmit 20 [1] 21 [2] r	Active: Always.
Input x (1 to 3) A to D	Factory use only.	HHHH		Input 1504 [1] 1505 [2] 1506 [3] r	Active: Always.
CJcX (1 to 3) A to D	Factory use only.	HHHH		Input 1501 [1] 1532 [2] 1532 [3] r	Active: Always.
CJcX (1 to 3) Temp	Cold junction compensation for the analog input. Reads the ambient temperature of the controller.	xx.x (xxx)		Input 1500 [1] 1531 [2] 1531 [3] r	Active: Always.
Line Frequency	Display the ac line frequency in hertz.	xx (xx)		1515 r	Active: Always.
Test					
Main > Factory > Test					
Test Outputs	Choose output to test.	All Off (0) Output 1A (1) Output 1B (2) Retransmit 1 (5) Retransmit 2 (6) Alarm 1 (7) Alarm 2 (8) All On (9) Communications (10)		1514 w	Active: Always.

✓ **Note:** Press the Information Key  for more task-related tips.

Factory Page Parameter Table

Parameter	Description	Range (Modbus Value)	Default	Modbus Register read/write (I/O, Set)	Conditions for Parameters to Appear
Display Test	Checks LED display segments by turning them on and off.	(1)		1513 w	Active: Always.
Full Defaults	Causes all parameter values to revert to their factory default settings.	Yes (800)		1602 r	Active: Always.

Calibrate Input x (1 to 3)

Main Page > Factory > Calibration > Calibrate Input x (1 to 3)

0.00mV Thermocouple	Store 0.000mV calibration for input thermocouple.	Yes (1)		1603 [1] 1608 [2] 1613 [3] r/w	Active: Always. Inputs 2 and 3 appear only if the controller is the enhanced version (F4P _ - _ _ AB - _ _ _ _).
50.00mV Thermocouple	Store 50.000mV calibration for input thermocouple.	Yes (2)		1603 [1] 1608 [2] 1613 [3] r/w	Active: Always. Inputs 2 and 3 appear only if the controller is the enhanced version (F4P _ - _ _ AB - _ _ _ _).
32°F Type J	Store 32°F type J calibration.	Yes (3)		1603 [1] 1608 [2] 1613 [3] r/w	Active: Always. Inputs 2 and 3 appear only if the controller is the enhanced version (F4P _ - _ _ AB - _ _ _ _).
Ground	Store calibration for ground at gains of 1 and 32.	Yes (4)		1603 [1] 1608 [2] 1613 [3] r/w	Active: Always. Inputs 2 and 3 appear only if the controller is the enhanced version (F4P _ - _ _ AB - _ _ _ _).
Lead	Store calibration for lead resistance.	Yes (5)		1603 [1] 1608 [2] 1613 [3] r/w	Active: Always. Inputs 2 and 3 appear only if the controller is the enhanced version (F4P _ - _ _ AB - _ _ _ _).
15.0 Ohms*	Store 15.00Ω calibration for input RTD.	Yes (6)		1603 [1] 1608 [2] 1613 [3] r/w	Active: Always. Inputs 2 and 3 appear only if the controller is the enhanced version (F4P _ - _ _ AB - _ _ _ _).
240.0 Ohms*	Store 240.00Ω calibration for the 500Ω or 1kΩ RTD input.	Yes (6)		1603 [1] 1608 [2] 1613 [3] w	Active: Always.
380.0 Ohms*	Store 380.00Ω calibration for input RTD.	Yes (7)		1603 [1] 1608 [2] 1613 [3] r/w	Active: Always. Inputs 2 and 3 appear only if the controller is the enhanced version (F4P _ - _ _ AB - _ _ _ _).

✓ **Note:** For more information about how parameter settings affect the controller's operation, see the Features Chapter.

*The tenth digit of your model number, F4PX-XXXX-XXXX, determines what RTD calibration resistance values the unit uses. Refer to the Ordering Information in the Appendix.

Options 1-4, 100Ω RTD - 15.00 and 380.00Ω

Options 5-8, 500Ω or 1000Ω RTD - 240.00 and 6080.00Ω

Factory Page Parameter Table

Parameter	Description	Range (Modbus Value)	Default	Modbus Register read/write (I/O, Set)	Conditions for Parameters to Appear
6080.0 Ohms*	Store 6080.00Ω calibration for the 500Ω or 1kΩ RTD input.	Yes (7)		Input 1603 [1] 1608 [2] 1613 [3] w	Active: Always.
0.000V	Store 0.000V calibration for the process input.	Yes (8)		1603 [1] 1608 [2] 1613 [3] r/w	Active: Always. Inputs 2 and 3 appear only if the controller is the enhanced version (F4P _ - _ _ AB - _ _ _ _).
10.000V	Store 10.000V calibration for the process input.	Yes (9)		1603 [1] 1608 [2] 1613 [3] r/w	Active: Always. Inputs 2 and 3 appear only if the controller is the enhanced version (F4P _ - _ _ AB - _ _ _ _).
4.000mA	Store 4mA calibration for the process input.	Yes (10)		1603 [1] 1608 [2] 1613 [3] r/w	Active: Always. Inputs 2 and 3 appear only if the controller is the enhanced version (F4P _ - _ _ AB - _ _ _ _).
20.000mA	Store 20mA calibration for the process input.	Yes (11)		1603 [1] 1608 [2] 1613 [3] r/w	Active: Always. Inputs 2 and 3 appear only if the controller is the enhanced version (F4P _ - _ _ AB - _ _ _ _).
15.0 Ohms	Store 15.00Ω calibration for the slidewire input.	Yes (12)		1603 [1] 1608 [2] 1613 [3] r/w	Active: Always. Inputs 3 appear only if the controller is the enhanced version (F4P _ - _ _ AB - _ _ _ _).
1000 Ohms	Store 1000.00Ω calibration for the slidewire input.	Yes (13)		1603 [1] 1608 [2] 1613 [3] r/w	Active: Always. Inputs 3 appear only if the controller is the enhanced version (F4P _ - _ _ AB - _ _ _ _).

Calibrate Output x (1A or 1B) and Retransmit x (1 and 2)

Main > Factory > Calibration > **Calibrate Output x (1A or 1B) and Retransmit x (1 and 2)**

4.000mA	Store 4mA calibration for the process output.	0.000mA to 6.000mA (0 to 6000)	4.000mA	Output 1604 [1A] 1609 [1B] Rexmit 1624 [1] 1629 [2] r/w	Active: Always.
20.000mA	Store 20mA calibration for the process output.	0.000 to 24.000mA (0 to 24000)	20.000mA	Output 1605 [1A] 1610 [1B] Rexmit 1625 [1] 1630 [2] r/w	Active: Always.

✓ **Note:** Press the Information Key ⓘ for more task-related tips.

*The tenth digit of your model number, F4PX-XXXX-XXXX, determines what RTD calibration resistance values the unit uses. Refer to the Ordering Information in the Appendix.

Options 1-4, 100Ω RTD - 15.00 and 380.00Ω
Options 5-8, 500Ω or 1000Ω RTD - 240.00 and 6080.00Ω

Factory Page Parameter Table

Parameter	Description	Range (Modbus Value)	Default	Modbus Register read/write (I/O, Set)	Conditions for Parameters to Appear
1.000V	Store 1.000V calibration for the process output.	0.000 to 3.000V (0 to 3000)	1.000V	Output 1606 [1A] 1611 [1B] Rexmit 1626 [1] 1631 [2] r/w	Active: Always.
10.000V	Store 10.000V calibration for process output.	0.000 to 12.000V (0 to 12000)	10.000V	Output 1607 [1A] 1612 [1B] Rexmit 1627 [1] 1632 [2] r/w	Active: Always.

Restore Input x (1 to 3) Calibration

Main > Factory > Calibration > Restore Input x (1 to 3) Calibration

Restore Input x (1 to 3) Calibration	Input 1 (0) Input 2 (1) Input 3 (2)	—	1601 write only	Active: Always. Inputs 2 and 3 appear only if the controller is the enhanced version (F4P _ - _ _ AB - _ _ _ _).
Restores original factory calibration values.				

✓ **Note:** For more information about how parameter settings affect the controller's operation, see the Features Chapter.

Notes:

7

Chapter Seven: Features

Inputs

Multiple Input Offsets	7.2
Filter Time Constant	7.3
Set Point Low Limit and High Limit	7.3
High Scale and Low Scale	7.4
Digital Inputs	7.4

Control Methods

Auto-Manual Control	7.5
On-Off Control	7.6
Proportional Control	7.6
PI Control	7.7
PID Control	7.7
Dead Band	7.7
Multiple PID Sets	7.8
Burst Fire	7.8

Other Features

Autotuning	7.9
Retransmit	7.9
Open Loop Detect	7.9

Alarms

Alarm Set Points	7.10
Alarm Hysteresis	7.10
Process, Deviation or Rate Alarms	7.10
Alarm Latching	7.11
Alarm Silencing	7.11
Alarm Sides	7.11

Advanced Features

Boost Heat and Boost Cool	7.12
Duplex	7.13
Digital Set Points	7.14

Features in Enhanced Series F4P Controller

Remote Set Point	7.15
Alternate Input	7.15
Cascade Control	7.16
Differential Control	7.17
Ratio Control	7.17
Slidewire Control	7.18

Inputs

Multiple Input Offsets

Offset points are used to compensate for differences between the target process value and the sensor value read by the Series F4P. Multiple offset points enable the F4P to compensate for non-linear differences between the sensor readings and target process values over the thermal or process system operating range. Sensor reading differences can be caused by sensor placement, tolerances, an inaccurate sensor or lead resistance.

The Series F4P controller supports both single point and multiple point offsets. The choice for single or multiple offsets is made in the Setup Page > Analog Input Menu.

A single point offset allows the F4P to control the process to one offset value difference linearly either above or below the sensed value over the entire operating range.

Multiple point offsets allow the Series F4P to control the process to 10 different offset points over the operating range. Each offset point has a programmable positive or negative offset value. Offset points can be positioned anywhere over the operating range. Offset point values are programmable between -1,000 and +1,000. Offset values are linearly interpolated between the nearest two offset points. Offset values are added to the sensed value to establish a target process value. Offset Point 1 is programmable as the first point or low end point of the range. Offset points 2 through 10 follow sequentially. Offset values lower than the first point (point 1) or higher than the last point (point 10) are zero.

Location in software: Setup Page > Analog Input x (1 to 3) Menu > Input Offset x (1 to 10).

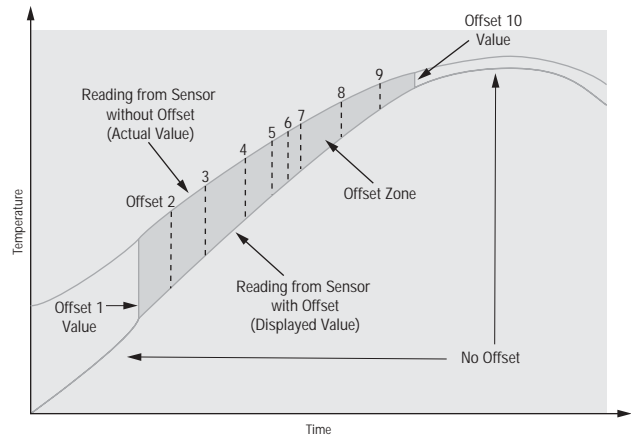

Figure 7.2 — Multiple Input Offsets.

Filter Time Constant

A time filter smooths an input signal by applying a first-order filter time constant to the signal. Either the displayed value or both the displayed and control values can be filtered. Filtering the displayed value makes it easier to monitor. Filtering the signal may improve the performance of PID control in a noisy or very dynamic system.

A positive value affects only the viewed values. A negative value affects both the viewed and control values.

Location in software: Setup Page > Analog Input x (1 to 3).

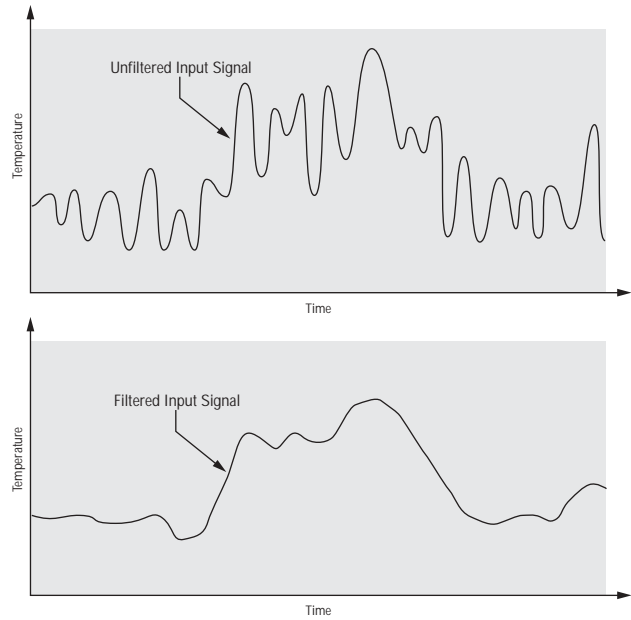

Figure 7.3a — Filtered and Unfiltered Input Signals.

Set Point Low Limit and High Limit

The controller constrains the set point to a value between a low limit and a high limit. The high limit cannot be set higher than the sensor high limit or lower than the low limit. The low limit cannot be set lower than the sensor low limit or higher than the high limit.

Location in software: Setup Page > Analog Input x (1 to 3).

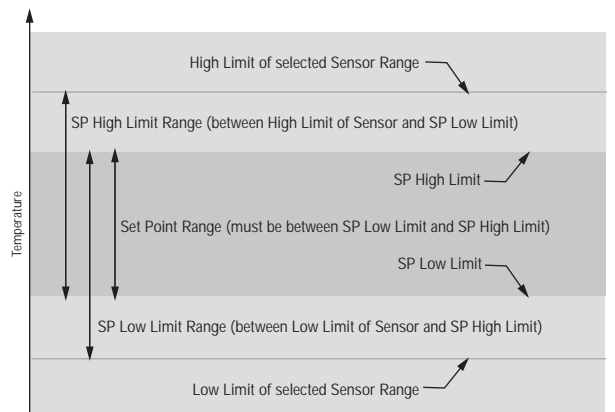

Figure 7.3b — Sensor Ranges.

High Scale and Low Scale

When an analog input is selected as a process input, you must choose a value to represent the low and high ends of the current or voltage range. For example, if an analog input with a process sensor type 4 to 20mA is selected, then 0 could represent 4mA and 100 could represent 20mA. The set point will be limited to the range between scale low and scale high.

Location in software: Setup Page > Analog Input and Setup Page > Retransmit Output x (1 or 2).

Scaling

When an analog input is selected as a process input, you must choose the scaling relationship of the current or voltage input signal to the Low Scale and High Scale parameters.

For example, with Normal Scaling selected, Scale Low = 0, and High Scale = 100 for a 4 to 20mA input, 0 represents 4mA and 100 represents 20mA. With Scale Inversion selected, the Scale Low value represents a 20 mA input signal and Scale High represents a 4 mA input signal.

The value entered for Scale Low must be less than the Scale High value with Normal Scaling or Inverse Scaling selected.

Location in software: Setup Page > Analog Input and Setup Page > Scaling.

Digital Inputs

With a digital input an operator can perform certain operations on a system by opening or closing a switch or applying a dc logic signal to the controller. This feature can add convenience, safety or security to a system.

In the Series F4P, digital inputs 1 to 4 can be assigned to display messages, switch to another set point or perform other process control features.

A low or high state will trigger an event for as long as that state exists. A rising edge will turn on an event when it changes from a low to a high state. The event will continue until the rising edge (low to high state) occurs again.



Location in software: Setup Page > Digital Input x (1 to 4) Condition.

Control Methods

Auto (closed loop) and Manual (open loop) Control

Auto (closed loop) control uses a process sensor to determine the difference between the process value and the set point. Then the controller applies power to a control output load in order to reduce that difference.

Manual (open loop) control allows the user to directly set and adjust the power level to the control output load.

The Series F4P Auto/Manual Indicator Light is on when the controller is in manual mode. The controller can only switch between auto and manual mode from the Main Page. To toggle between manual and auto mode, first press the  key, then confirm your selection in the lower display. The indicator light will flash after you press the  key until you confirm your choice or 10 seconds have elapsed.

In manual mode, the user manually adjusts the output power level. Changes take effect when the new value has been entered and the controller is back in the Main Page.

Before it switches from manual to auto mode the F4P checks to make certain a functioning sensor is connected to analog input 1.

The user can select how the Series F4 determines a set point when it makes a transition from manual to auto operation. It can automatically switch back to the last set point it used in auto mode or use reverse bumpless transfer, which will establish a set point that equals the process value at the time it was switched from manual mode.

Location in software: Setup Page > System.

The user can protect the process being controlled by selecting the maximum control output power levels that will be allowed when the controller switches from auto to manual power.

Location in software: Setup Page > System > Maximum Heat Transfer Power and Maximum Cool Transfer Power.

On-Off Control

On-off control switches the output either full on or full off, depending on the input, set point and hysteresis values. The hysteresis value indicates the amount the process value must deviate from the set point to turn on the output. Increasing the value decreases the number of times the output will cycle. Decreasing hysteresis improves controllability. With hysteresis set to 0 the process value would stay closer to the set point, but the output would switch on and off more frequently, causing “chattering.”

Set the proportional band to 0 to set the controller to on-off control mode.

Proportional Band x (A or B) location in software: Operations Page > Edit PID > PID Set x (1 to 5).

Hysteresis x (A or B) location in software: Operations Page > Edit PID > PID Set x (1 to 5).

✓ NOTE:

Fail power does not function in on-off control mode.

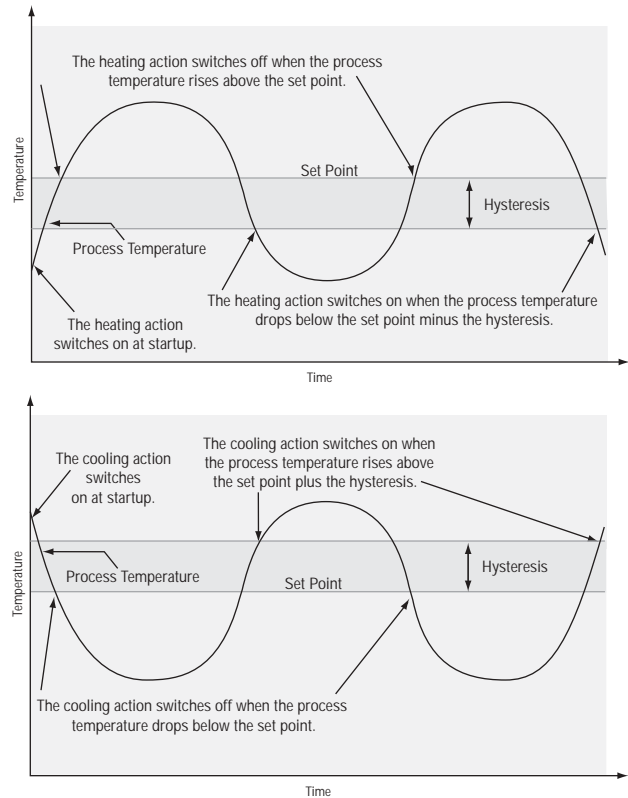

Figure 7.6a — On-Off Control for Heating and Cooling.

Proportional Control

Some processes need to maintain a temperature or process value closer to the set point than on-off control can provide. Proportional control provides closer control by adjusting the output when the temperature or process value is within a proportional band. When the value is in the band, the controller adjusts the output based on how close the process value is to the set point; the closer to set point the lower the output. This is similar to backing off on the gas pedal of a car as you approach a stop sign. It keeps the temperature or process value from swinging as widely as it would with simple on-off control. However, when a system settles down, the temperature or process value tends to “droop” short of the set point.

With proportional control the output power level equals (set point minus process value) divided by propband.

Location in software: Operations Page > Edit PID > PID Set x (1 to 5).

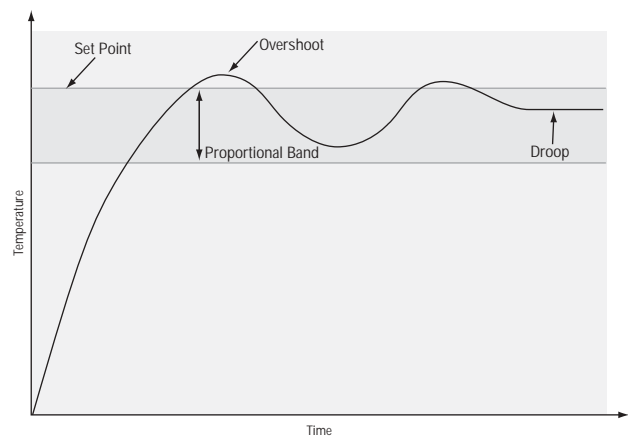

Figure 7.6b — Proportional Control.

Proportional plus Integral (PI) Control

The droop caused by proportional control can be corrected by adding integral control. When the system settles down the integral value is tuned to bring the temperature or process value closer to the set point. Integral determines the speed of the correction, but this may increase the overshoot at startup or when the set point is changed. Too much integral action will make the system unstable. Integral is cleared when the process value is outside of the proportional band.

Integral (if units are set to SI) is measured in minutes per repeat. A low integral value causes a fast integrating action.

Reset (if units are set to U.S.) is measured in repeats per minute. A high reset value causes a fast integrating action.

Location in software: Operations Page > Edit PID > PID Set x (1 to 5).

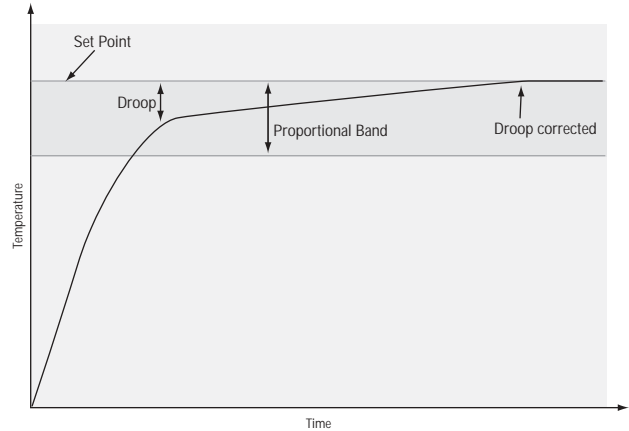

Figure 7.7a — Proportional Plus Integral Control.

Proportional Integral Derivative (PID) Control

Use derivative control to minimize overshoot in a PI-controlled system. Derivative adjusts the output based on the rate of change in the temperature or process value. Too much derivative will make the system sluggish.

Location in software: Operations Page > Edit PID > PID Set x (1 to 5).

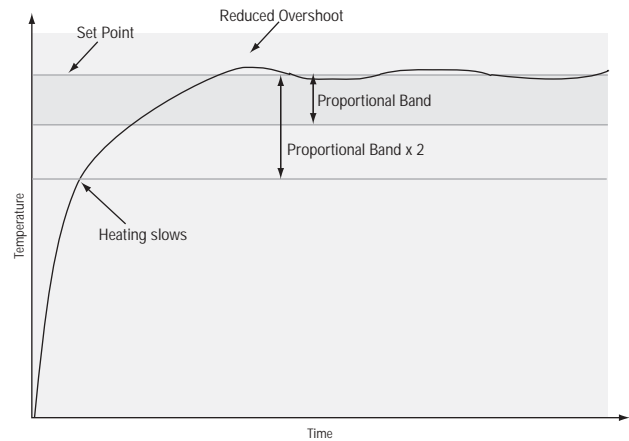

Figure 7.7b — PID Control.

Dead Band

In a PID application the dead bands above and below the set point can save an application's energy and wear by maintaining process temperature within acceptable ranges. Shifting the effective cooling set point and heating set point keeps the two systems from fighting each other.

Proportional action ceases when the process value is within the dead band. Integral action continues to bring the process temperature to the set point. When the dead band value is zero, the heating element activates when the temperature drops below the set point, and the cooling element switches on when the temperature exceeds the set point.

Location in software: Operations Page > Edit PID > PID Set x (1 to 5).

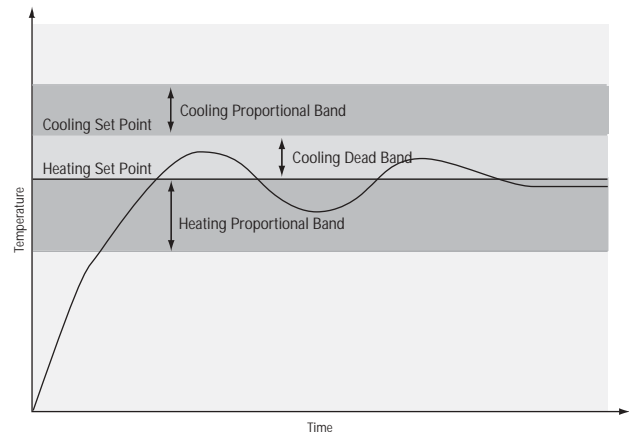

Figure 7.7c — Cooling Dead Band.

Multiple PID Sets

The Series F4P supports up to five heat/cool PID sets. This feature is extremely valuable if the characteristics of your thermal system vary over its operating range. All PID sets can be auto tuned or manually tuned. PID sets can be edited in the Operations Page. The Series F4P can be programmed to operate using any of the five sets based on crossover points of the set point or process value. These programming choices are made in the Operations Page > PID Crossover.

When the process or set point value crosses the crossover point, the PID set designated for that region of the operating range is used to control the percent power being supplied to the load.

There is a -1° hysteresis for each crossover. A rising temperature will change PID sets at the crossover value. A falling temperature will change PID sets at the crossover value -1° .

Location in software: Operations Page > Edit PID > PID Crossover x (1 to 4).

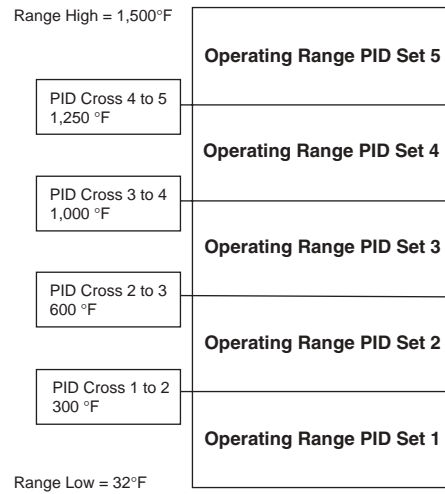

Figure 7.8a — Multiple PID Sets.

Burst Fire (variable-time base)

Burst firing provides even output power with the lowest level of noise generation (RFI). Burst fire is the preferred method for controlling a resistive load, providing a very short time base for longer heater life.

The controller determines when the ac sine wave will cross the 0-volts point, then switches the load on or off only at this point, minimizing RFI.

Location in software: Setup Page > Control Output x (1A or 1B).

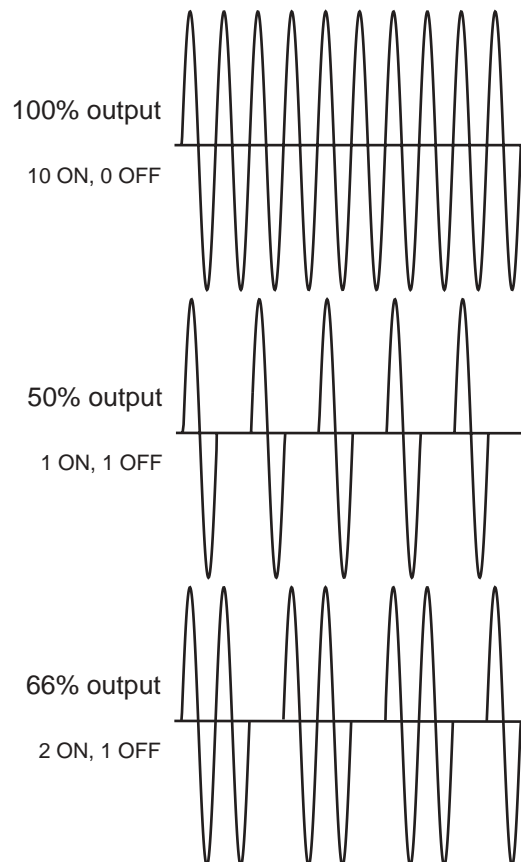

Figure 7.8b — Burst Fire.

Other Features

Autotuning

The autotuning feature allows the controller to measure the system response to determine effective settings for PID control. When autotuning is initiated the controller reverts to on-off control. The temperature must cross the auto-tune set point four times to complete the autotuning process. Once complete, the controller controls at the normal set point, using the new parameters. The F4P stores the value in the PID set specified.

Location in software: Operations Page > Autotune PID > PID Set x (1 to 5).



CAUTION: Choose an auto-tune set point value that will protect your product from possible damage from overshoot or undershoot during the autotuning oscillations. If the product is sensitive, carefully select the auto-tune set point to prevent product damage.

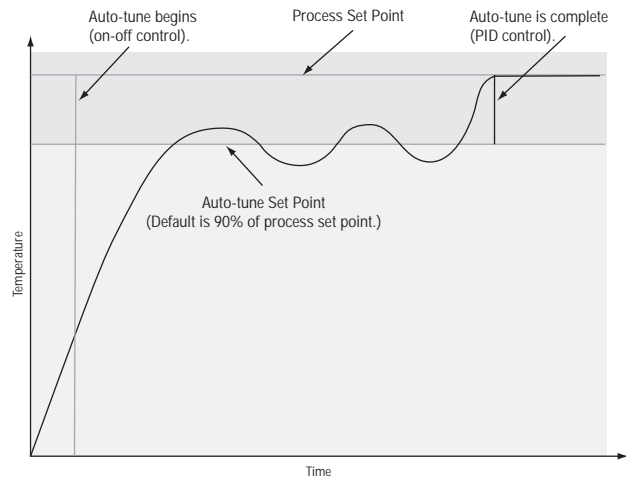

Figure 7.9 — Autotuning.

✓ **NOTE:**

For manual tuning, see the Operations Chapter.

Retransmit

Retransmit outputs 1 and 2 can retransmit an analog signal to serve as an input variable for another device. The signal may serve as a remote set point for another controller or as input for a chart recorder to document system performance over time.

Location in software: Setup Page.

Open Loop Detect

Open loop checks the integrity of the control loop, consisting of the controller output, power control, heater and sensor.

If the output power is at its maximum for a period of time equal to the reset time and the input has not changed at least $\pm 5^{\circ}\text{F}$, the controller will switch to Manual Mode at 0% output power. The upper screen will display **OLP** and the lower screen will display “Open Loop.”

To clear an open loop error, after correcting the problem that caused it, turn the controller off then back on.

Location in software: Setup Page > System.

Alarms

Alarms are activated when the process value or temperature leaves a defined range. A user can configure how and when an alarm is triggered, what action it takes and whether it turns off automatically when the alarm condition is over.

Configure alarm outputs in the Setup Page before setting alarm set points.

Alarm Set Points

The alarm high set point defines the process value or temperature that will trigger a high side alarm. It must be higher than the alarm low set point and lower than the high limit of the sensor range.

The alarm low set point defines the temperature that will trigger a low side alarm. It must be lower than the alarm high set point and higher than the low limit of the sensor range.

Location in software: Operations Page > Alarm Set Point > Alarm x (1 or 2).

Alarm Hysteresis

An alarm state is triggered when the process value reaches the alarm high or alarm low set point. Alarm hysteresis defines how far the process must return into the normal operating range before the alarm can be cleared.

Alarm hysteresis is a zone inside each alarm set point. This zone is defined by adding the hysteresis value to the alarm low set point or subtracting the hysteresis value from the alarm high set point.

Location in software: Setup Page > Alarm Output x (1 or 2).

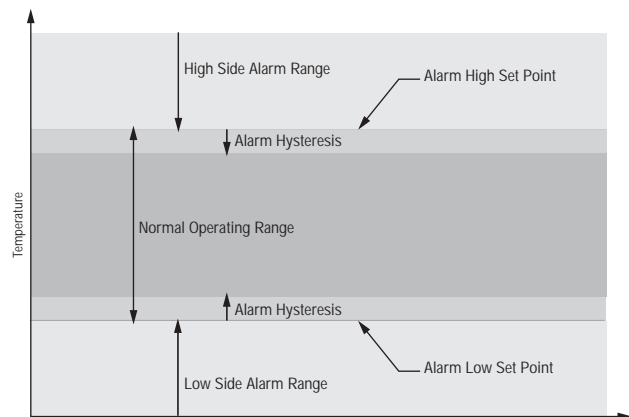

Figure 7.10 — Alarm Settings.

Process, Deviation or Rate Alarms

A process alarm uses one or two absolute set points to define an alarm condition. A deviation alarm uses one or two set points that are defined relative to the control set point. High and low alarm set points are calculated by adding and/or subtracting offset values from the control set point. If the set point changes, the window defined by the alarm set points automatically changes with it.

A rate alarm is triggered by a change in temperature or process value that exceeds the selected rate.

Location in software: Setup Page > Alarm Output x (1 or 2).

Alarm Latching

A latched alarm will remain active after the alarm condition has passed. It can only be deactivated by the user. An alarm that is not latched (self-clearing) will deactivate automatically when the alarm condition has passed.

Location in software: Setup Page > Alarm x (1 or 2).

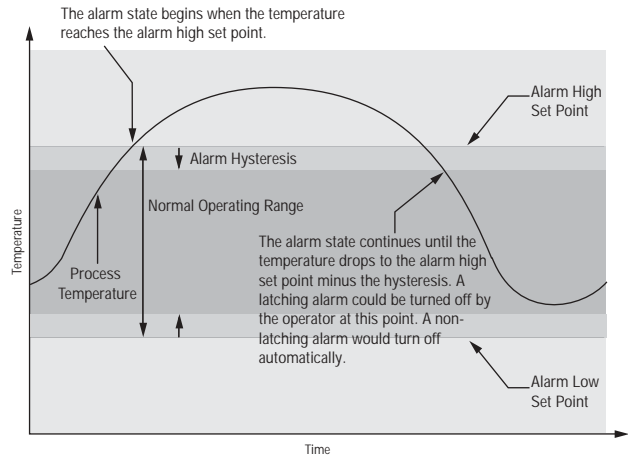

Figure 7.11a — Alarm Latching.

Alarm Silencing

Alarm silencing has two uses:

1. It is often used to allow a system to warm up after it has been started up. With alarm silencing on, an alarm is not triggered when the process temperature is initially lower than the alarm low set point. The process temperature has to enter the normal operating range beyond the hysteresis zone to activate the alarm function.
2. Alarm silencing also allows the operator to disable the alarm output while the controller is in an alarm state. The process temperature has to enter the normal operating range beyond the hysteresis zone to activate the alarm output function.

If the Series F4P has an output that is functioning as a deviation alarm, the alarm is silenced when the set point is changed, until the process value re-enters the normal operating range.

Location in software: Setup Page > Alarm x (1 or 2).

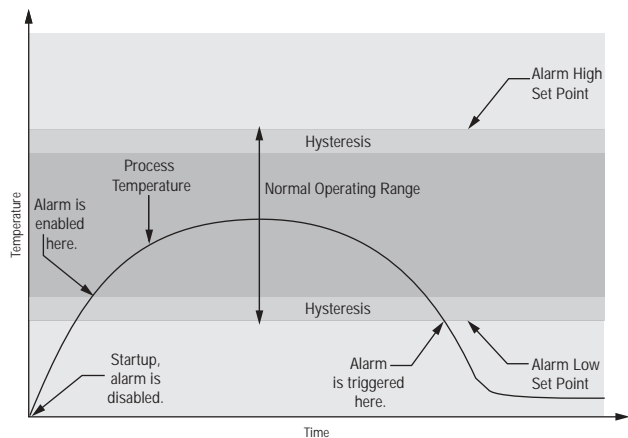

Figure 7.11b — Alarm Silencing.

Alarm Sides

Alarms can be configured to trigger when the process exceeds the High Alarm Set Point, the Low Alarm Set Point or both.

Location in software: Setup Page > Alarm x (1 or 2).

(Alarm set points are established in the Operations Page.)

Advanced Features

Boost Heat and Boost Cool

Boost operation is supported on output 1B. Boost is enabled when outputs 1A and 1B are configured to perform the same function: heat/heat or cool/cool.

The type of boost operation chosen in the output 1B menu can be either boost on power or boost on set point.

When boost on power is selected, output 1B is turned on or off based on the output load power requirements.

Boost on power can be enabled for operation in the auto mode only or in both the auto and manual mode. If chosen, the power level at which output 1B will be turned on is set in the Operations Page > Control Set Points. A delay time can also be set. The delay time will delay the turn on of the boost output until the power level is exceeded for the time of the delay. There is a 5% power level hysteresis between boost on and boost off operation.

When boost on set point is selected, output 1B is turned on or off based on a programmable set point value or on a deviation from the set point value. Boost set points and boost deviation values are set in the Operations Page > Control Set Points.

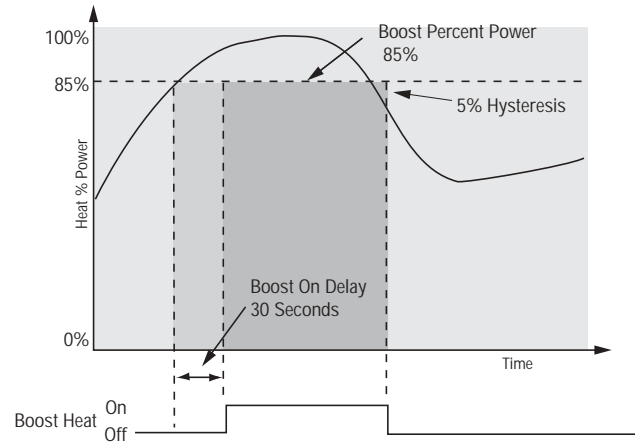

Figure 7.12a — Boost Heat Based on Output Power.

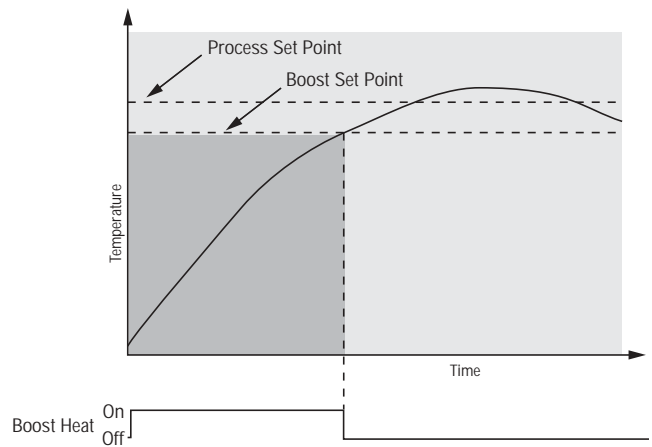

Figure 7.12b — Boost Heat Based on a Fixed Set Point.

Duplex

Certain systems require that a single process output control both heating and cooling outputs. A Series F4P controller with a process output in output 1A (F4P _ - F _ A A - _ _ _ _) can function as two separate outputs.

With a 4 to 20mA output the heating output, for instance, will operate from 12 to 20mA (0 to +100%) and the cooling outputs will operate from 12 to 4mA (0 to -100%). In some cases this type of output is required by the device that the Series F4P controls, such as a three-way valve that opens one way with a 12 to 20mA signal and opens the other way with a 4 to 12mA signal. This feature reduces the overall system cost by using a single output to act as two outputs.

Location in software: Setup Page > Control Output 1A > Function.

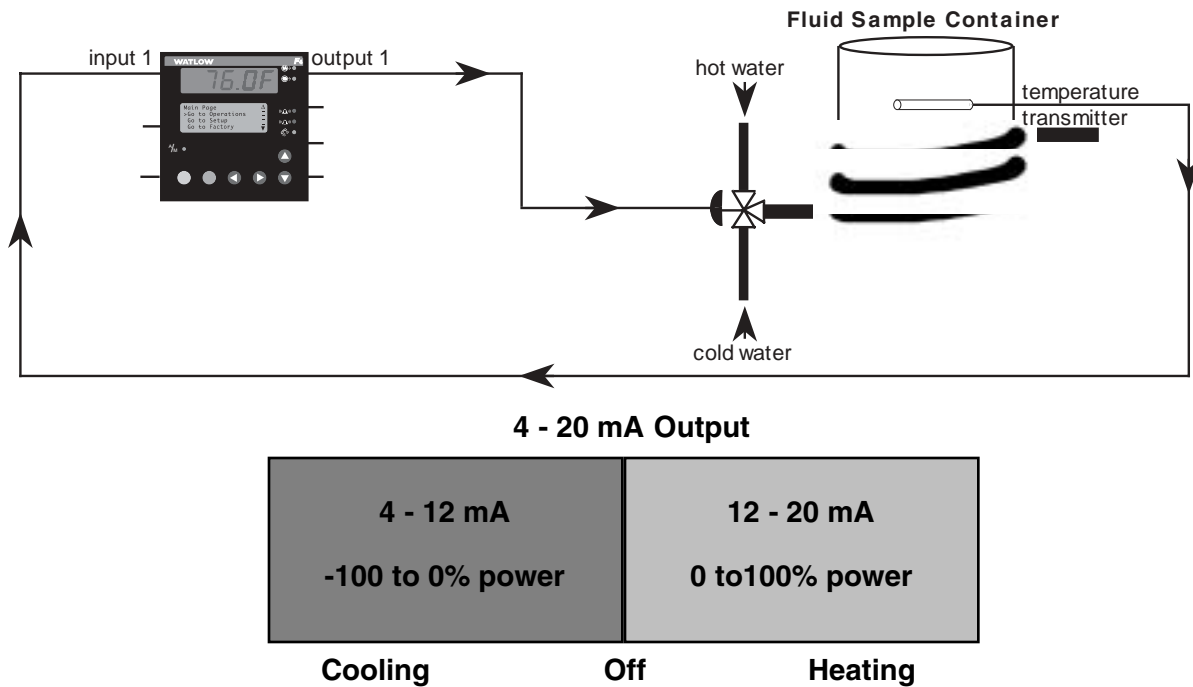

Figure 7.13 — Duplex Application Example.

Digital Set Points

Up to four nameable digital set points can be configured to control the Series F4P outputs. Each of the Series F4P's four digital inputs can be configured to select a different set point value.

When the digital set point function is selected in the Digital Input Menu, an adjustable digital set point value parameter (with the default name of "Dig. SPX") will be displayed in the Operation Menu > Control Set Points.

When the selected digital input goes to its true condition (which is determined on the Setup Page) the Series F4P will control to the enabled digital set point value. The enabled digital set point value and name will replace the local set point displayed on the Main Page. This set point is not adjustable from the Main Page.

Only one digital set point can be enabled at a time. If more than one digital input is configured as a digital set point, priority will be based on the order scanned by the Series F4P.

The enabled digital set point remains enabled for as long as the digital input is in its true condition. When no digital set points are enabled, control in the closed-loop mode will revert to the local set point value.

Location in software: Setup Page > Digital Set Point x (1 to 4).

(Digital set points are set or changed in the Operating Page.)

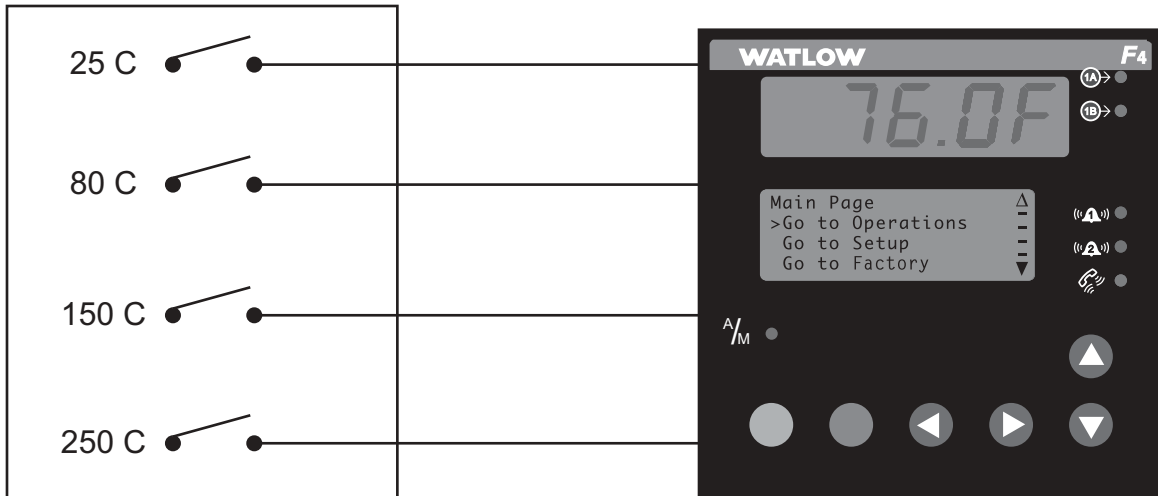

Figure 7.14 — Digital Set Points System Example.

Features in the Enhanced Series F4P Controller

Remote Set Point

The Series F4P with the enhanced control option can be configured to support up to two remote set points. This feature allows the closed-loop, process set point to be changed remotely.

In remote set point operation the measured process value of the remote set point input is used as the control set point in closed-loop operation. Analog inputs 2 and 3 can be configured as remote set point inputs. Remote set point (Remote 2 and Remote 3) values are limited in range to the operating range of the sensor selected for analog input 1, unless the operating range of the remote set point input sensor is less than the operating range of input 1. If that is the case, the remote set point sensor operating range will be used.

The switch to a remote set point input as the control set point can be made with a digital input or by selection in

the Operations Menu. Remote set point operation is masked if it is not enabled in the analog input 2 and 3 menus. Remote set point operation has priority over local set point operation when selected by one of the four digital inputs.

Location in software: Setup Page > Analog Input x (2 or 3) and Setup Page > Digital Input x (1 to 4).

Alternate Control

The Series F4P with the enhanced control option can be configured to have analog input 1 or analog input 2 function as the sensor input for closed-loop control. This feature can be used to support the need for redundant sensor operation or where sensor location or sensor type changes can improve process control.

The transition between inputs is made through the operation of the designated digital input. To ensure proper control operation the sensor used for analog inputs 1 and 2 must be the same. The linearization type can be different. Example, a K thermocouple can be used on input 1 and a J thermocouple can be used on input 2. The decimal value and unit type follows the input 1 selection.

The Series F4P firmware considers the sensor not being used to be off. Out-of-operating-range transitions will cause the Series F4 to switch to the manual mode. Transitions from outside the set point operating range will

cause the control set point to go to either the low or high set point limit, which ever is closer.

The alternate input option is only available in normal control operation. The remote set point and digital set point features are not available when alternate input operation is enabled.

Location in software: Setup Page > Analog Input 2 and Setup Page > Digital Input x (1 to 4)

Cascade

Cascade control is a control strategy in which one control loop provides the set point for another loop. It allows the process or part temperature to be reached quickly while minimizing overshoot. Cascade is used to optimize the performance of thermal systems with long lag times.

This graph illustrates a thermal system with a long lag time. Curve A represents a single-loop control system with PID parameters that allow a maximum heat-up rate. Too much energy is introduced and the set point is overshoot. In most systems with long lag time, the process value may never settle out to an acceptable error. Curve C represents a single-control system tuned to minimize overshoot. This results in unacceptable heat-up rates, taking hours to reach the final value. Curve B shows a cascade system that limits the energy introduced into the system, allowing an optimal heat-up rate with minimal overshoot.

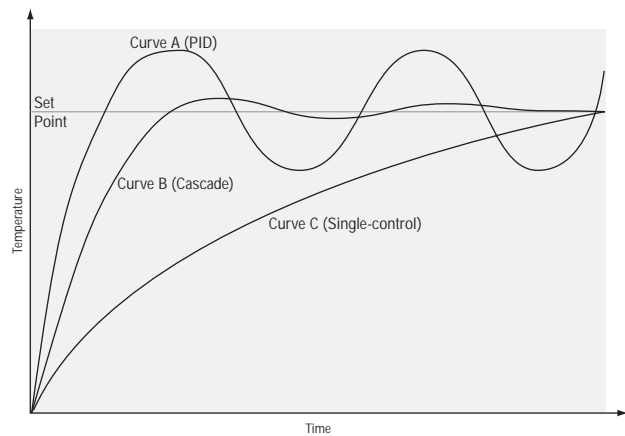

Figure 7.16a -- Control Lag Times

Cascade control uses two control loops (outer and inner) to control the process. The outer loop (analog input 3) monitors the process or part temperature, which is then compared to the set point. The result of the comparison, the error signal, is acted on by the settings in a Cascade Outer Loop PID set (1 to 5), which then generates a power level for the outer loop. The set point for the inner loop is determined by the outer-loop power level and the Cascade Low Range/Deviation and the Cascade High Range/Deviation settings for analog input 3.

The inner loop (analog input 1) monitors the energy source (heating and cooling), which is compared to the inner loop set point generated by the outer loop. The result of the comparison, the error signal, is acted on by the settings in a Cascade Inner Loop PID set (1 to 5), which generates an output power level between -100% to +100%. If the power level is positive the heat will be on; if the power level is negative the cool will come on.

In Series F4 controllers, cascade control is available on channel 1. Analog input 3 is used to measure the outer-loop process while analog input 1, the inner loop, is used to measure the energy source. Power from the energy sources are supplied by outputs 1A and 1B.

To set up and tune a system for cascade control, see the Operations Chapter.

Location in software: Setup Page and Operations Page. To set up and tune a system for cascade control, see the Operations Chapter.

Location in software: Setup Page and Operations Page

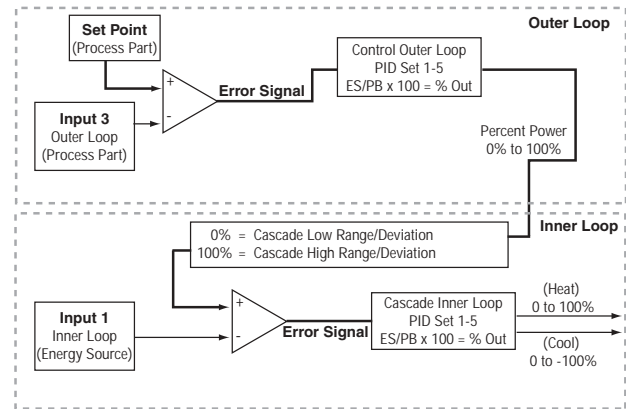

Figure 7.16b -- Cascade Control

✓ **NOTE:** Cascade Low Range and Cascade High Range Set Points for Input 1 (as shown above) are setup under Analog Input 3. Refer to Setup Chapter.

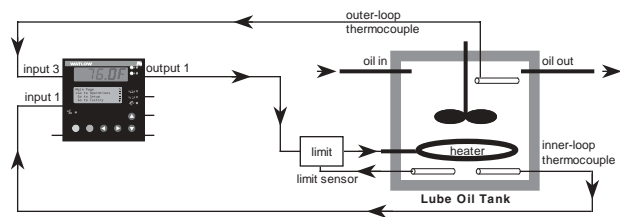

Figure 7.16c -- Cascade Example

Slidewire Control

The Series F4P with the enhanced control option can be configured to support slidewire valve control. In slidewire control a closed-loop process value, is measured at analog input 1 and compared to the control set point. The difference between the measured value and the control set point generates an error signal which is acted on by PID to generate a percent output. The percent output generated by PID is compared to the slidewire resistance measured at analog input 3 to determine if the valve needs to be closed or opened to decrease the difference between the closed loop process value and set point.

Two, time-proportioned outputs are required to control the valve position. Control output 1A is used to close the valve and output 1B is used to open the valve. Output 1A can be configured as heat (reverse) acting or cool (direct) acting. With output 1A set to cool (direct) the valve will open as the process value increases and power in the manual mode will be adjustable from 0% to 100%. With output 1A set to heat (reverse) the valve will close as the process value increases and power in the manual mode will be adjustable from 0% to +100%.

With PID generating a 25% output, output 1A set to cool (direct), a slide-wire resistance range of 100 to 1200 ohms and slidewire resistance measured on analog input 3 is greater than 275 ohms (25% of span) output 1B will be on opening the valve to increase the cooling effect to decrease the process value until the measured resistance equals 25% of span. With the same conditions and the measured resistance less than 275 ohms (25% of span)

output 1A will be closing the valve to decrease the cooling effect until the measured resistance equals 25% of span.

To select slidewire control, set Analog Input 3 > Sensor to Slidewire. The slidewire feature can be calibrated either automatically or manually.

Fine tune the behavior of the slidewire control using the Hunt and Hysteresis parameters, in Setup Page > Analog Input 3 > Slidewire.

Location in software: Setup Page > Analog Input 3.

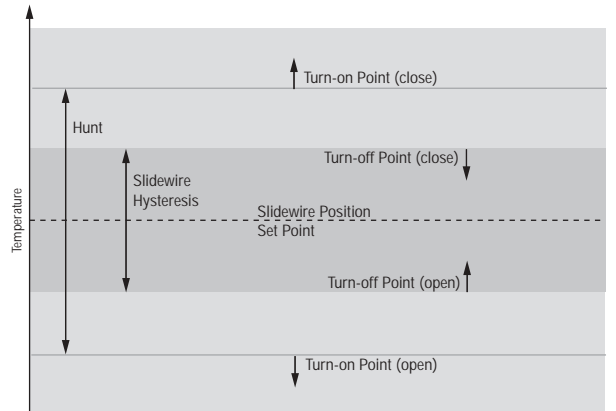

Figure 7.18a — Slidewire Hunt and Hysteresis.

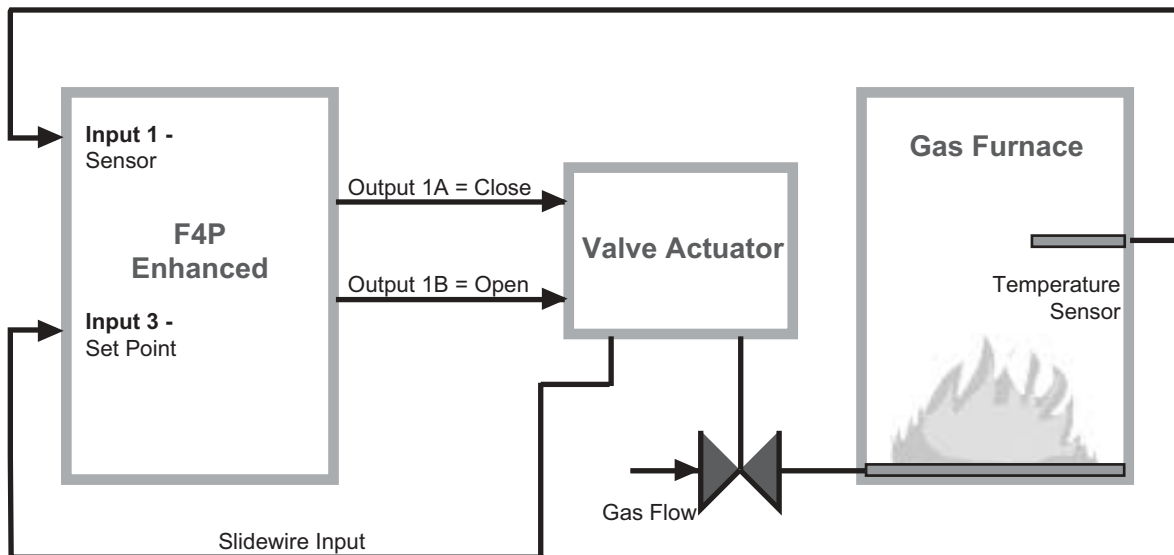

Figure 7.18b — Slidewire Feedback Application Example.

Notes:

Notes:

8

Chapter Eight: Installation & Wiring

Dimensions	8.1
Installing the Series F4P	8.3
Removing the Series F4P	8.4
Input-to-Output Isolation	8.5
Power Wiring	8.5
Sensor Installation Guidelines	8.5
Input 1	8.6
Inputs x (2 and 3)	8.7
Digital Inputs x (1 to 4)	8.9
Outputs x (1A and 1B)	8.10
Retransmit and Alarm Output	8.11
Communications Wiring	8.12
Wiring Example	8.14
Wiring Notes	8.15

Dimensions

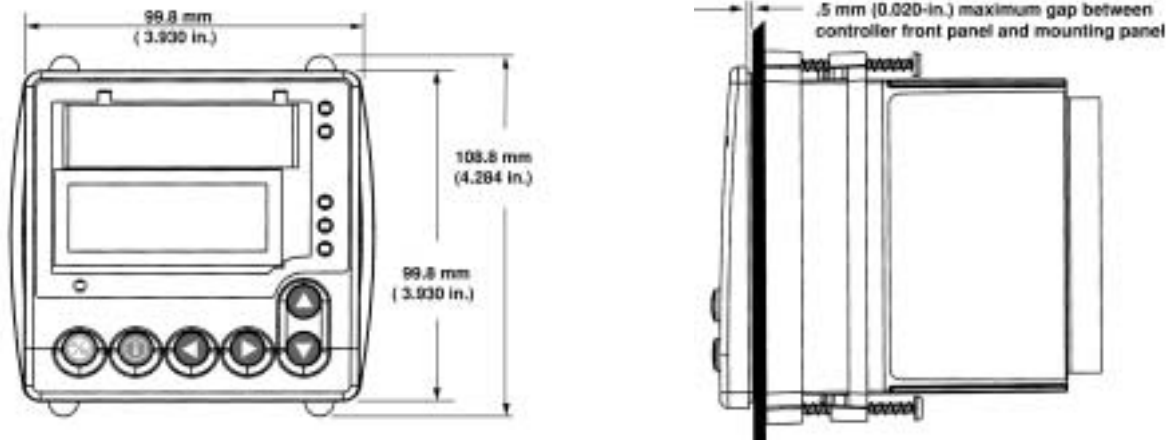

Figure 8.1 — Front View Dimensions and Gasket Gap Dimension.

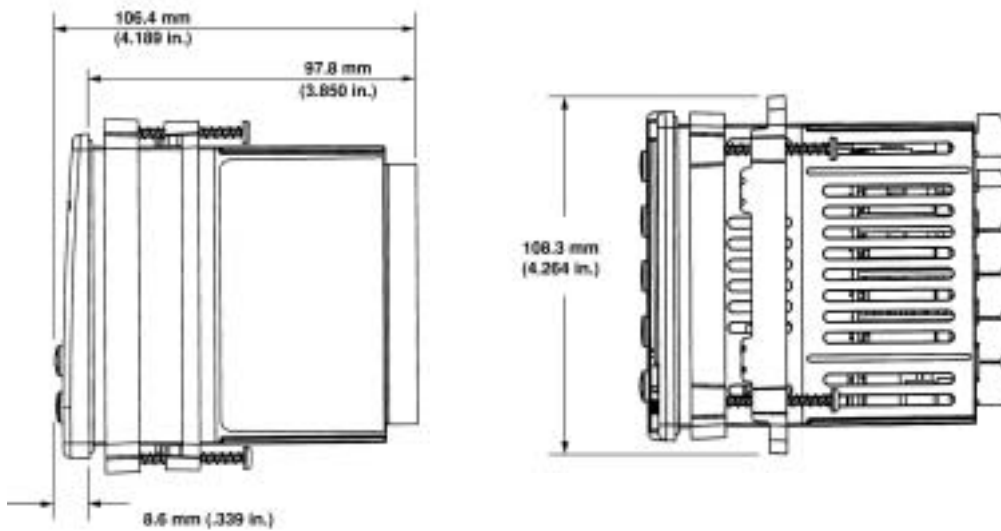

Figure 8.2a — Side and Top View and Dimensions.

Panel Dimensions

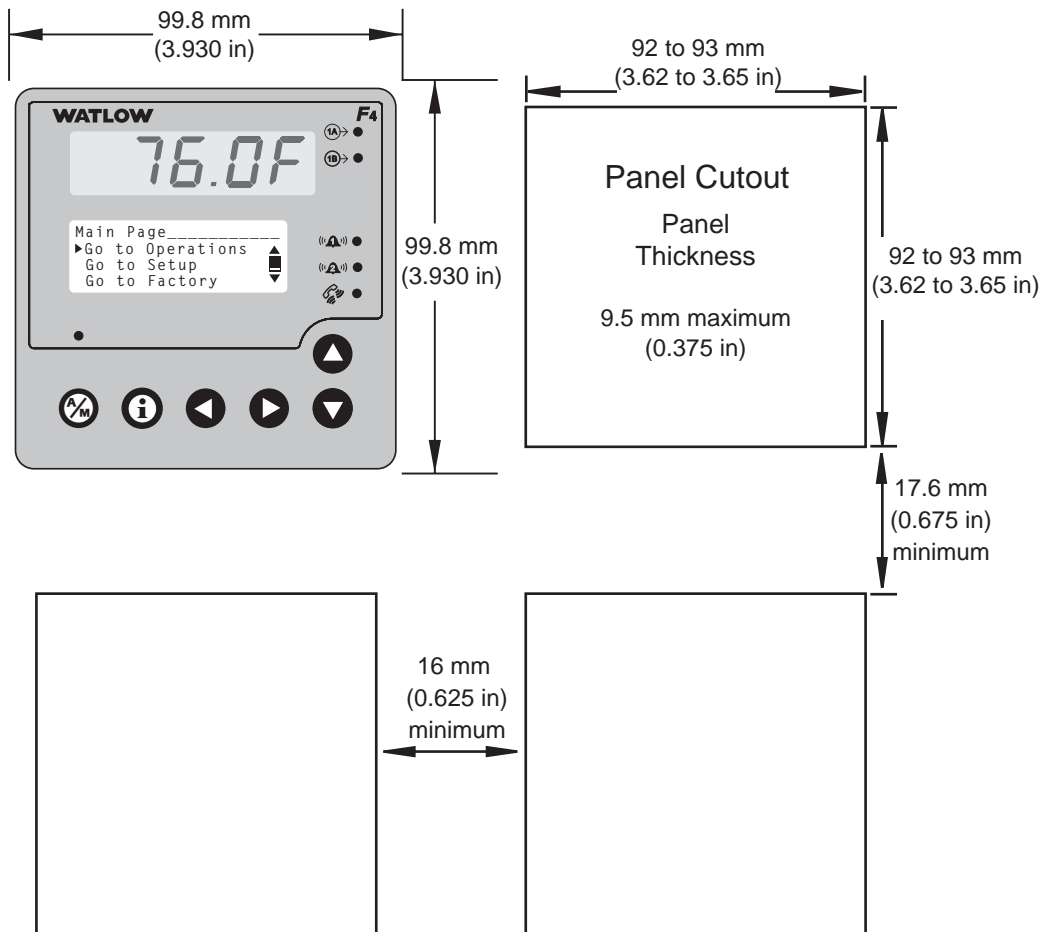

Figure 8.2b — Multiple Panel Cutout Dimensions.

Installing the Series F4P Controller

Installing and mounting requires access to the back of the panel.

Tools required: one #2 Phillips screwdriver.

1. Make the panel cutout using the mounting template dimensions in this chapter.
2. Insert the controller into the panel cutout. Check that the rubber gasket lies in its slot at the back of the bezel. Slide the retention collar over the case, with open holes facing the back of the case.
3. Align the mounting bracket with the screws tips pointed toward the panel. Squeezing the bowed sides of the bracket, push it gently but firmly over the case until the hooks snap into the slots at the front of the case.
4. If the installation does not require a NEMA 4X seal, tighten the four screws with the Phillips screwdriver just enough to eliminate the spacing between the rubber gasket and the mounting panel.

For a NEMA 4X seal, tighten the four screws until the gap between the bezel and panel surface is .020 inch maximum. (See figure 3c). Make sure that you cannot move the controller back and forth in the cutout. If you can, you do not have a proper seal. **Do not overtighten.** Overtightening could damage the the mounting bracket.

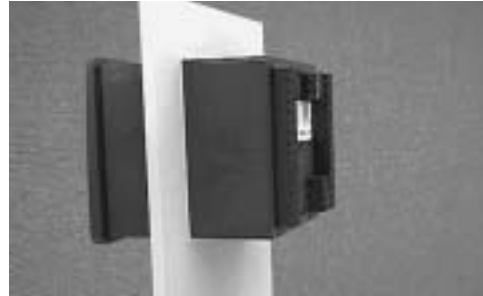

Figure 8.3a — Gasket Seated on the Bezel.

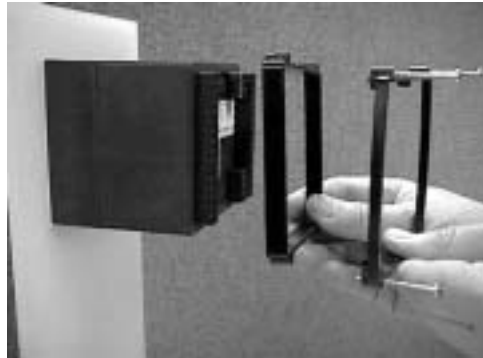

Figure 8.3b — Retention Collar and Mounting Bracket.



Figure 8.3c — Tightening the Screws.

Removing the Series F4P Controller

The controller can be removed most easily by disengaging the mounting bracket hooks and pushing the controller forward through the panel. Be ready to support it as it slides forward through the panel.

Tools required: one #2 Phillips screwdriver, one flat-head screwdriver and some means of supporting the controller as it slides out the front of the panel.

1. Remove all the wiring connectors from the back of the controller. Using the Phillips screwdriver, unscrew the four screws on the mounting bracket (two on top, two on bottom) until the tips are completely retracted into the shafts.
2. Slide the tip of a flat screwdriver between the case and the center top side of the mounting bracket. Rotate the screwdriver 90 degrees, stretching the bracket away from the case so the hooks on the bracket disengage from the slots on the case. Hold the bracket and press the controller forward slightly to prevent the disengaged hooks from snapping back into the slots.
3. Repeat this operation to disengage the hooks on the bottom side of the mounting bracket.
4. Press with one or two fingers on the lower half of the back of the unit so that the controller slides forward through the panel. Hold the bracket steady; do not pull back. Be ready to support the controller as it comes through the front panel. Remove the mounting brackets and retention collar from the back side of the panel.



Figure 8.4 — Disengaging the Mounting Bracket.

Wiring the Series F4P

Wiring options depend on the model number, which is printed on the label on the back of the controller. The model number codes are explained in the Appendix.

The labels on the sides and back of the controller contain some basic wiring information.

Input-to-Output Isolation

The Series F4P uses optical and transformer isolation to provide a barrier to prevent ground loops when using grounded sensors and/or peripheral equipment.

Here is a breakdown of the isolation barriers:

- Analog input 1 and all the digital inputs are grouped together.
- Analog inputs 2 and 3 are grouped together.
- All the control outputs and retransmit outputs are grouped together.
- Both alarm outputs are grouped together.
- Communications is isolated from the other inputs and outputs.

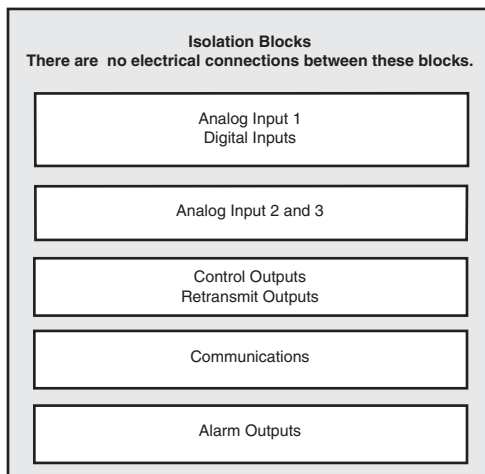

Figure 8.5a — Isolation Blocks.



WARNING: Provide a labeled switch or circuit breaker connected to the Series F4P power wiring as the means of disconnection for servicing. Failure to do so could result in damage to equipment and/or property, and/or injury or death to personnel.

Power Wiring

100 to 240V \approx (ac/dc), nominal (85 to 264 actual) F4PH - _
 - - - - -

The Series F4P has a non-operator-replaceable fuse Type T (time-lag) rated at 2.0 or 5.0A @ 250V \sim (ac).

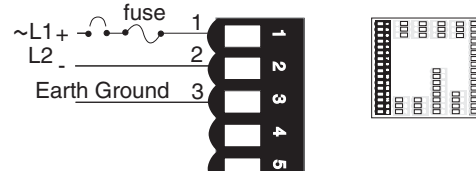

Figure 8.5b — Power Wiring.

Sensor Installation Guidelines

Thermocouple inputs: Extension wire for thermocouples must be of the same alloy as the thermocouple to limit errors.

If a grounded thermocouple is required for input 2, the signal to input 3 must be isolated to prevent possible ground loops.

RTD input: Each 1 of lead wire resistance can cause a +2°F error when using a two-wire RTD. A three-wire RTD sensor overcomes this problem. All three wires must have the same electrical resistance (i.e., same gauge, same length, multi-stranded or solid, same metal).

Process input: Isolation must be maintained between input 2 and input 3. If both input 2 and input 3 are process signals, a separate power supply and transmitter must be used for each input. These inputs must be electrically isolated from one another to prevent ground loops.



WARNING: To avoid damage to property and equipment, and/or injury or loss of life, use National Electric Code (NEC) standard wiring practices to install and operate the Series F4P. Failure to do so could result in such damage, and/or injury or death.



WARNING: To avoid damage to property and equipment, and/or injury or loss of life, use National Electric Code (NEC) standard wiring practices to install and operate the Series F4P. Failure to do so could result in such damage, and/or injury or death.

Input 1

Figure 8.6a — Thermocouple

Available on all units.
Impedance: 20M Ω

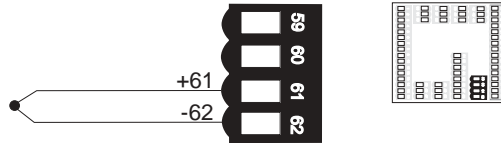
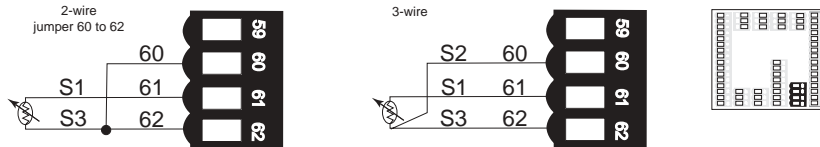

Figure 8.6b — RTD (2- or 3-Wire) 100, 500 or 1000 Ω Platinum

Available on all units.

The last two digits of the model number determine RTD calibration.



CAUTION: Maintain isolation between analog inputs 2 and 3, and between analog input 1 and digital inputs 1-4 to prevent a ground loop. A ground loop may cause incorrect readings or error codes. Failure to follow this guideline could result in damage to equipment and product.

Figure 8.6c — 0-5V $\overline{\text{m}}$, 1-5V $\overline{\text{m}}$ or 0-10V $\overline{\text{m}}$ (dc) Process

Available on all units.
Input impedance: 20k Ω

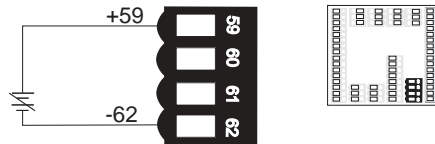

WARNING: Process inputs may not have sensor break protection. Outputs can remain full on.

Figure 8.6d — 0-20mA or 4-20mA Process

Available on all units.
Input impedance: 100 Ω

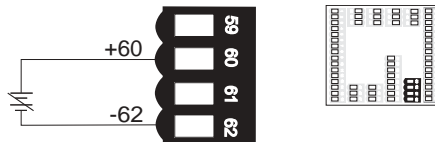
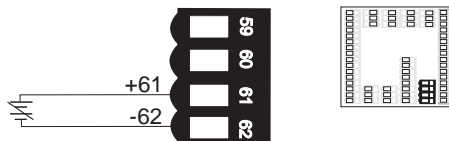

Figure 8.6e — 0 to 50mV

Available on all units
Impedance: 20M Ω



Inputs x (2 and 3)



WARNING: To avoid damage to property and equipment, and/or injury or loss of life, use National Electric Code (NEC) standard wiring practices to install and operate the Series F4P. Failure to do so could result in such damage, and/or injury or death.

Figure 8.7a — Thermocouple

F4P _ _ _ AB - _ _ _ _

Impedance: 20MΩ

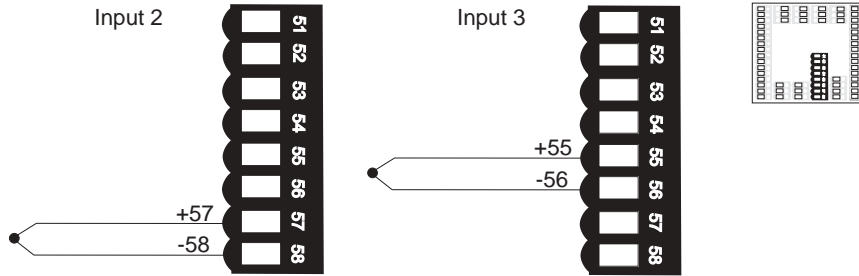

Figure 8.7b — RTD (2-wire) 100, 500 or 1000Ω Platinum

F4P _ _ _ AB - _ _ _ _

The last two digits of the model number determine RTD calibration.

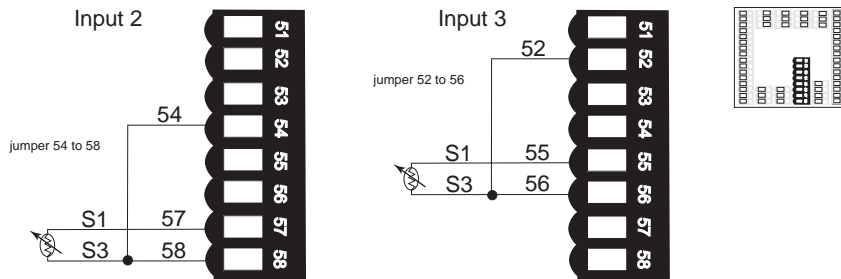
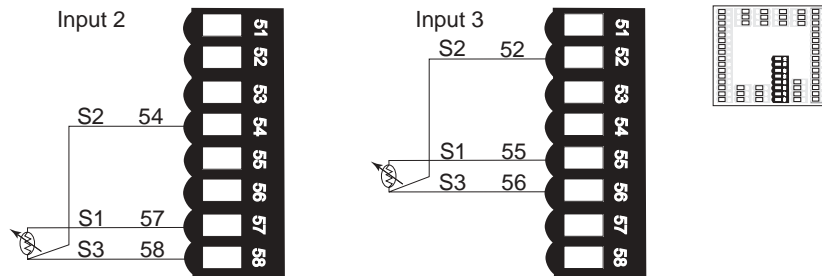

Figure 8.7c — RTD (3-wire) 100, 500 or 1000Ω Platinum

F4P _ _ _ AB - _ _ _ _

The last two digits of the model number determine RTD calibration.



CAUTION: Maintain isolation between analog inputs 2 and 3, and between analog input 1 and digital inputs 1-4 to prevent a ground loop. A ground loop may cause incorrect readings or error codes. Failure to follow this guideline could result in damage to equipment and product.

Inputs x (2 and 3) (continued)



WARNING: To avoid damage to property and equipment, and/or injury or loss of life, use National Electric Code (NEC) standard wiring practices to install and operate the Series F4P. Failure to do so could result in such damage, and/or injury or death.

Figure 8.8a — 0-5V_{DC}, 1-5V_{DC} or 0-10V_{DC} (dc) Process

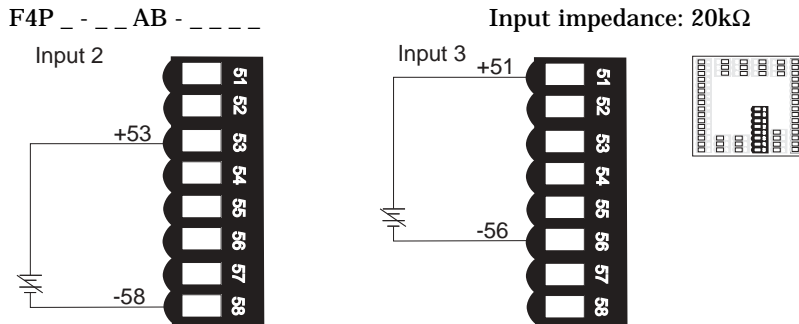
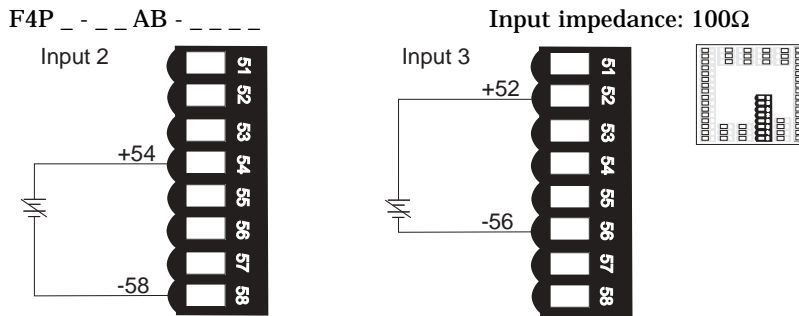
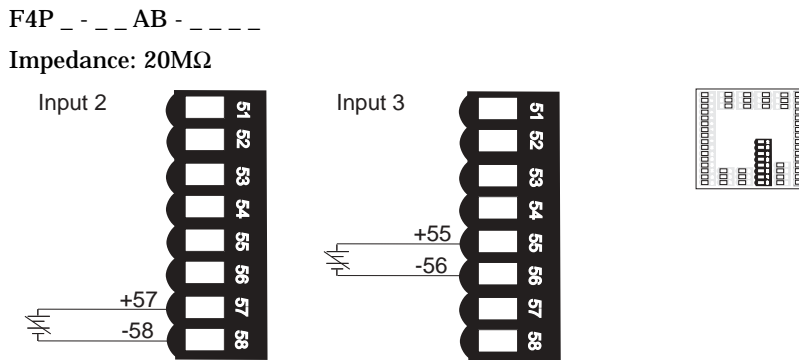

Figure 8.8b — 0-20mA or 4-20mA Process



CAUTION: Maintain isolation between analog inputs 2 and 3, and between analog input 1 and digital inputs 1-4 to prevent a ground loop. A ground loop may cause incorrect readings or error codes. Failure to follow this guideline could result in damage to equipment and product.

Figure 8.8c — 0 to 50mV



WARNING: Process inputs may not have sensor break protection. Outputs can remain full on.

Figure 8.8d — Slidewire Input (Input 3 only)

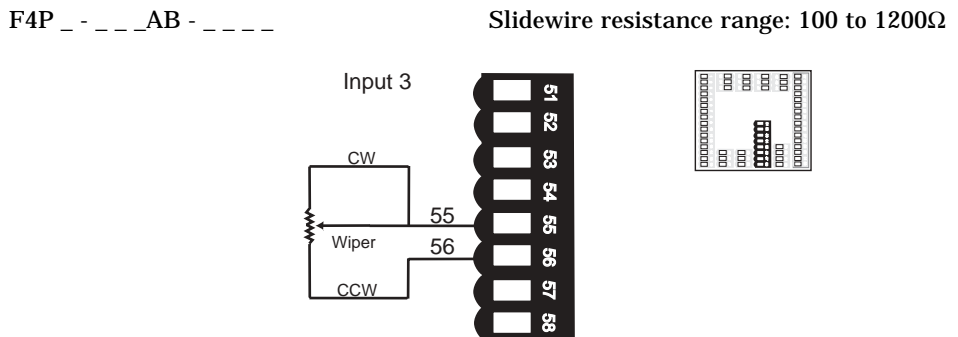

Digital Inputs x (1 to 4)



WARNING: To avoid damage to property and equipment, and/or injury or loss of life, use National Electric Code (NEC) standard wiring practices to install and operate the Series F4P. Failure to do so could result in such damage, and/or injury or death.



CAUTION: Maintain isolation between analog inputs 2 and 3, and between analog input 1 and digital inputs 1-4 to prevent a ground loop. A ground loop may cause incorrect readings or error codes. Failure to follow this guideline could result in damage to equipment and product.

Figure 8.9 — Digital Inputs x (1 to 4)

Voltage input

- 0-1V_{DC} (dc) Event Input Low State
- 2-36V_{DC} (dc) Event Input High State

Contact closure

- 0-2k Ω Event Input Low State
- > 7k Ω Event Input High State

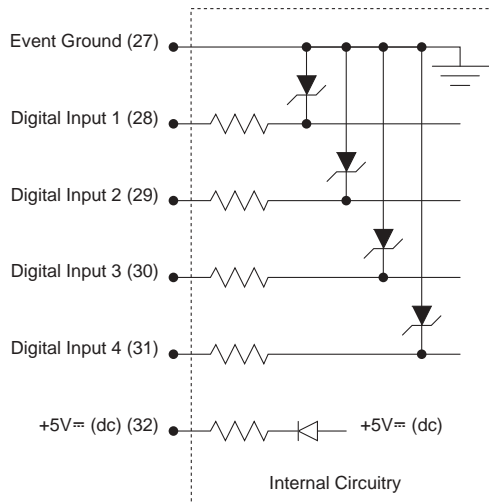
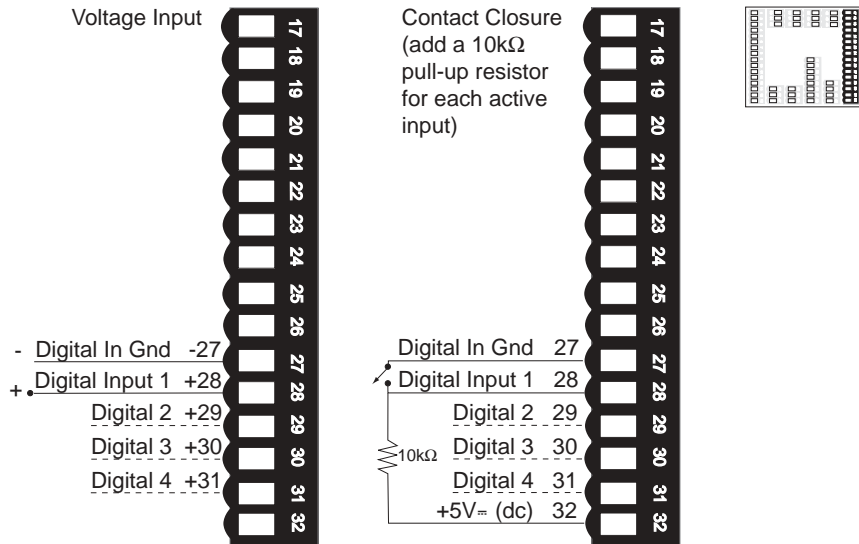

Outputs 1A and 1B

✓ **Note:** Switching inductive loads (relay coils, solenoids, etc.) with the mechanical relay, switched dc or solid-state relay output options requires use of an R.C. suppressor.

Watlow carries the R.C. suppressor Quencharc brand name, which is a trademark of ITW Paktron. Watlow Part No. 0804-0147-0000.



WARNING: To avoid damage to property and equipment, and/or injury of loss of life, use National Electric Code (NEC) standard wiring practices to install and operate the Series F4P. Failure to do so could result in such damage, and/or injury or death.

Figure 8.10a — **Solid-state Relay**

24V~ (ac) minimum, 253V~ (ac) maximum

0.5 amps, off-state impedance 31MΩ

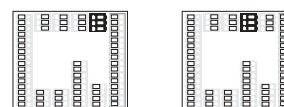
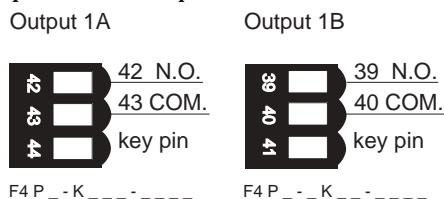

Figure 8.10b — **Switched DC, Open Collector**

• Switched dc configuration (COM not used)

DC+ is 22 to 28V^{dc} (dc)

Maximum supply current is 30mA

• Open collector output (dc+ not used)

DC- is 42V^{dc} (dc) maximum

Off: 10mA maximum leakage

On: 0.2V @ 0.5 amps sink

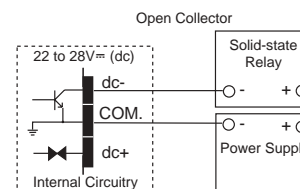
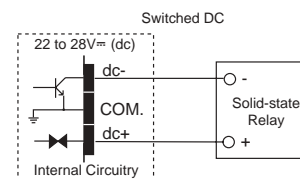
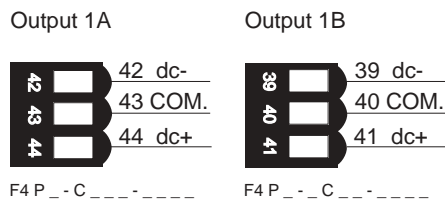
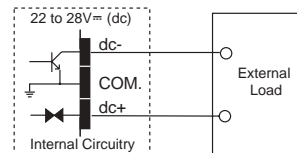
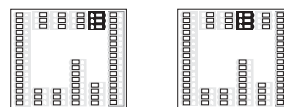
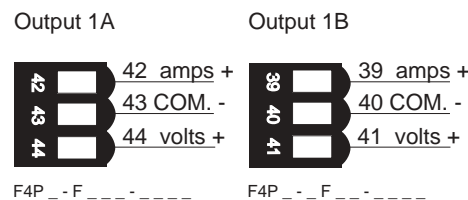

Figure 8.10c — **0-20mA, 4-20mA, 0-5V^{dc}, 1-5V^{dc} and 0-10V^{dc} Process**

mA maximum load impedance is 800Ω

V^{dc} (dc) minimum load impedance is 1KΩ



Outputs 1A and 1B (continued)

✓ **Note:** Switching inductive loads (relay coils, solenoids, etc.) with the mechanical relay, switched dc or solid-state relay output options requires use of an R.C. suppressor.

Watlow carries the R.C. suppressor Quencharc brand name, which is a trademark of ITW Paktron. Watlow Part No. 0804-0147-0000.

Figure 8.11a — Mechanical Relay

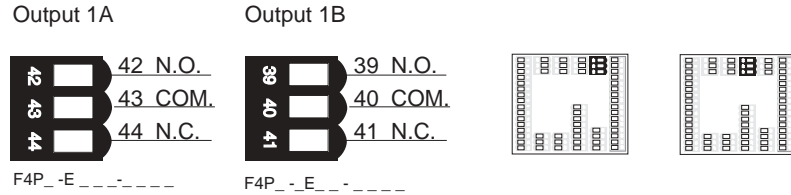

Retransmit and Alarm Output

Figure 8.11b — Retransmit Outputs x (1 and 2)

mA maximum load impedance is 800Ω
 V_{dc} (dc) minimum load impedance is 1KΩ

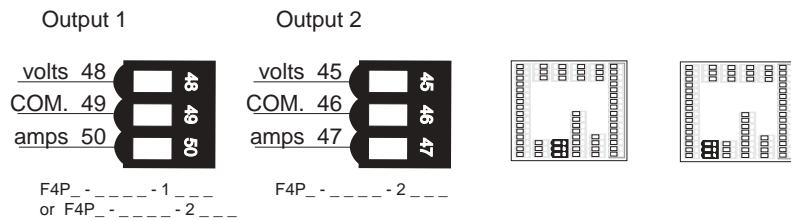

WARNING: To avoid damage to property and equipment, and/or injury or loss of life, use National Electric Code (NEC) standard wiring practices to install and operate the Series F4P. Failure to do so could result in such damage, and/or injury or death.



CAUTION: Maintain isolation between outputs 1A, 1B and between the retransmit outputs to prevent ground loops. A ground loop may cause incorrect readings or error codes. Failure to follow this guideline could result in damage to equipment and product.

Figure 8.11c — Alarm Outputs x (1 and 2)

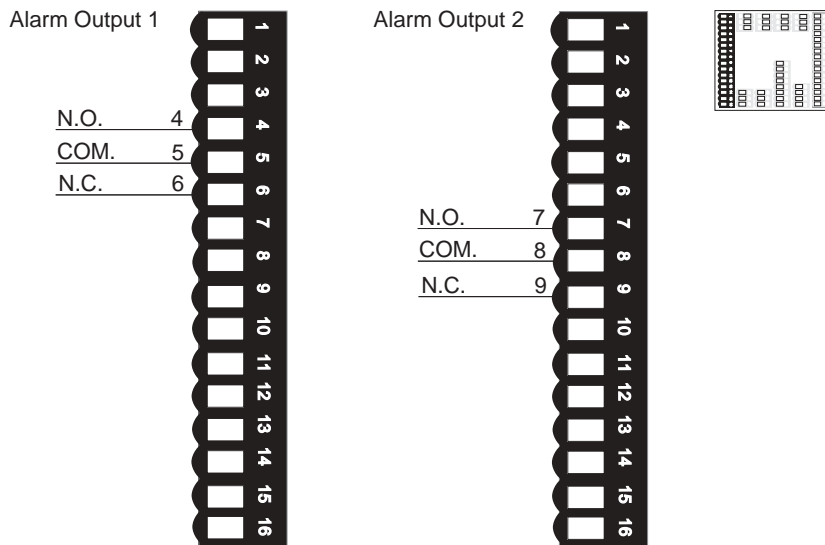

Electromechanical relay without contact suppression
 Form C, 2 amp, off-state impedance is 31mΩ

Communications Wiring



WARNING: To avoid damage to property and equipment, and/or injury or loss of life, use National Electric Code (NEC) standard wiring practices to install and operate the Series F4P. Failure to do so could result in such damage, and/or injury or death.

Figure 8.12a — EIA/TIA 485 and EIA/TIA 232 Communications

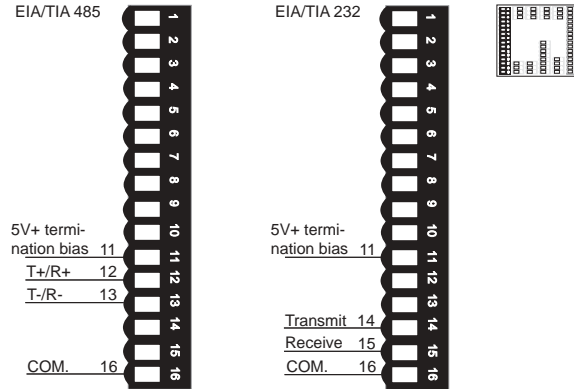
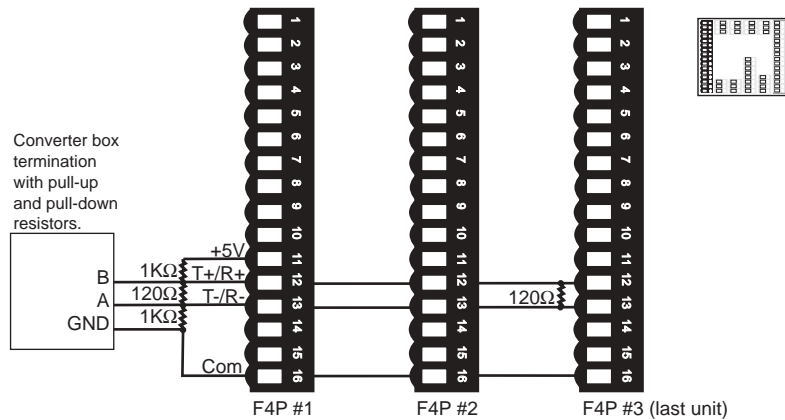
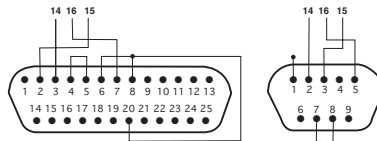

Figure 8.12b — Termination for EIA-232 to EIA-485 Converter



If the system does not work properly, it may need termination resistors at each end of the network. A typical installation would require a 120-ohm resistor across the transmit/receive terminals (12 and 13) of the last controller in the network and the converter box or serial card. Pull-up and pull-down 1k ohm resistors may be needed on the first unit to maintain the correct voltage during the idle state.

Figure 8.12c — EIA/TIA-232 Connections



Wire Color	F4 232	DB 9 Connector	DB25 Connector
White	TX Pin 14	RX Pin 2	RX Pin 3
Red	RX Pin 15	TX Pin 3	TX Pin 2
Black	GND Pin 16	Gnd Pin 5	GND Pin 7
Green	GND Pin 24	N/U Pin 9	N/U Pin 22
Shield	N/C	Gnd Pin 5	Gnd Pin 7

Communications Wiring (continued)



WARNING: To avoid damage to property and equipment, and/or injury or loss of life, use National Electric Code (NEC) standard wiring practices to install and operate the Series F4P. Failure to do so could result in such damage, and/or injury or death.

✓ **Note:** The CMC converter requires an external power supply when used with a laptop computer.

Figure 8.13a — EIA/TIA 232 to EIA/TIA 485 Conversion

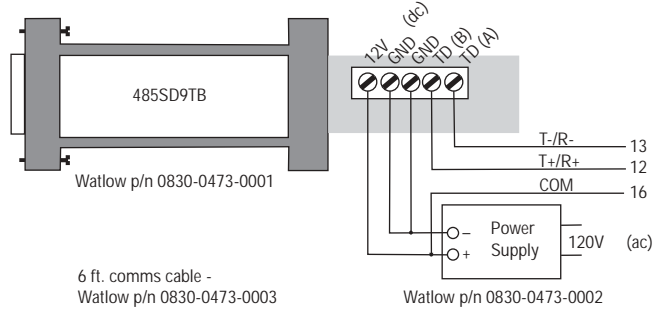

B&B Converter (B&B Electronics Manufacturing Company, 815 433-5100, www.bb-elec.com)

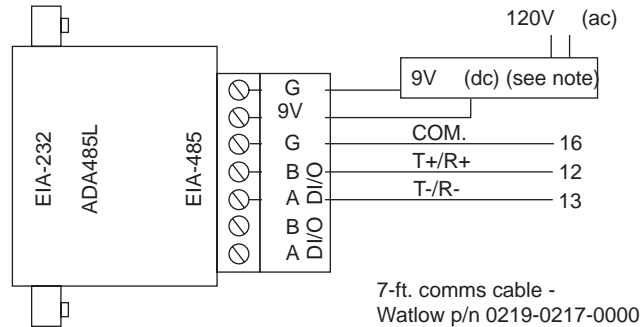

CMC Converter (CMC Connecticut Micro-Computer, Inc., 800-426-2872, www.2cmc.com)

Figure 8.13b — GPIB Conversion to EIA/TIA 232 or EIA/TIA 485 Communications with Modbus RTU

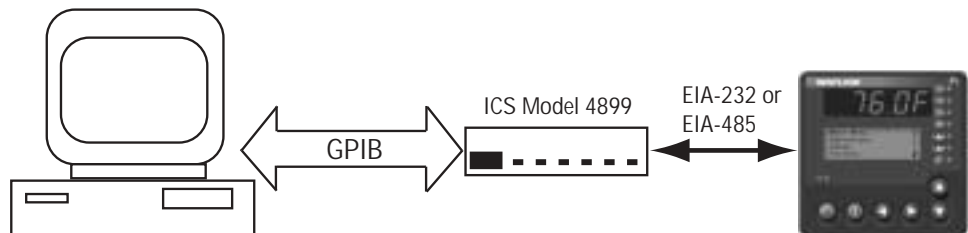

ICS GPIB Bus Interface (ICS Electronics, 925 416-1000, www.icselect.com)

Wiring Example



WARNING: To avoid potential electric shock and damage to property and equipment, use National Electric Code (NEC) safety practices when wiring and connecting this unit to a power source and to electrical sensors or peripheral devices. Failure to do so could result in injury or death..

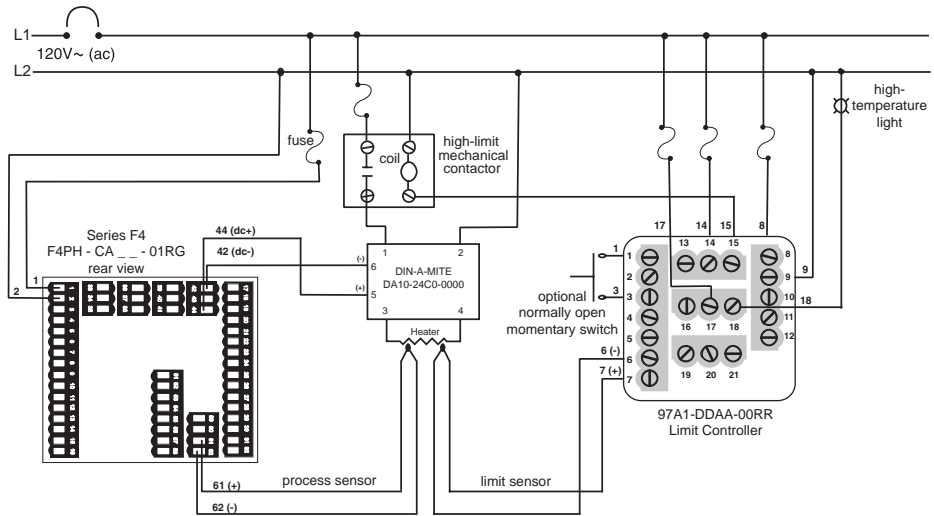

WARNING: Install high- or low-temperature limit control protection in systems where an overtemperature or undertemperature fault condition could present a fire hazard or other hazard. Failure to comply with this recommendation may result in damage to equipment and property and injury to personnel.

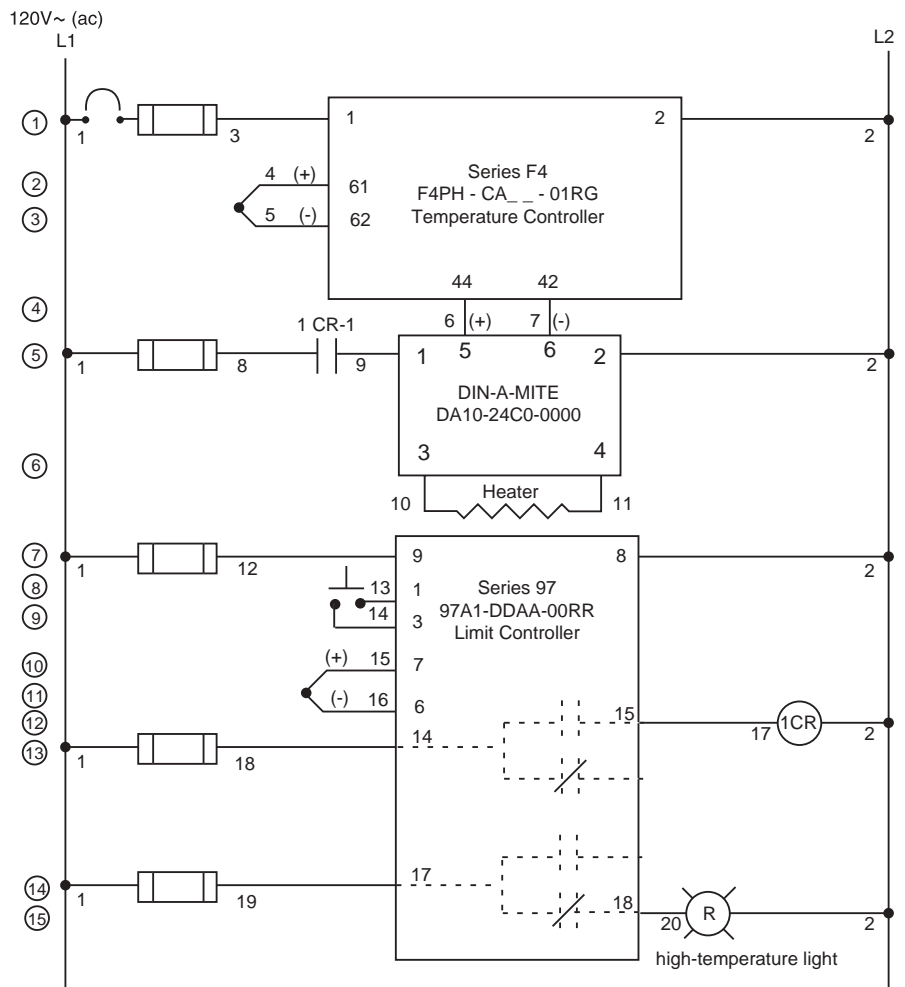
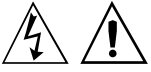

Figure 8.14 — System Wiring Example

Wiring Notes



Sketch in your application on this page or a copy of it. See the wiring example in this chapter.

WARNING: To avoid potential electric shock and damage to property and equipment, use National Electric Code (NEC) safety practices when wiring and connecting this unit to a power source and to electrical sensors or peripheral devices. Failure to do so could result in injury or death.



WARNING: Install high- or low-temperature limit control protection in systems where an overtemperature or undertemperature fault condition could present a fire hazard or other hazard. Failure to comply with this recommendation may result in damage to equipment and property and injury to personnel.

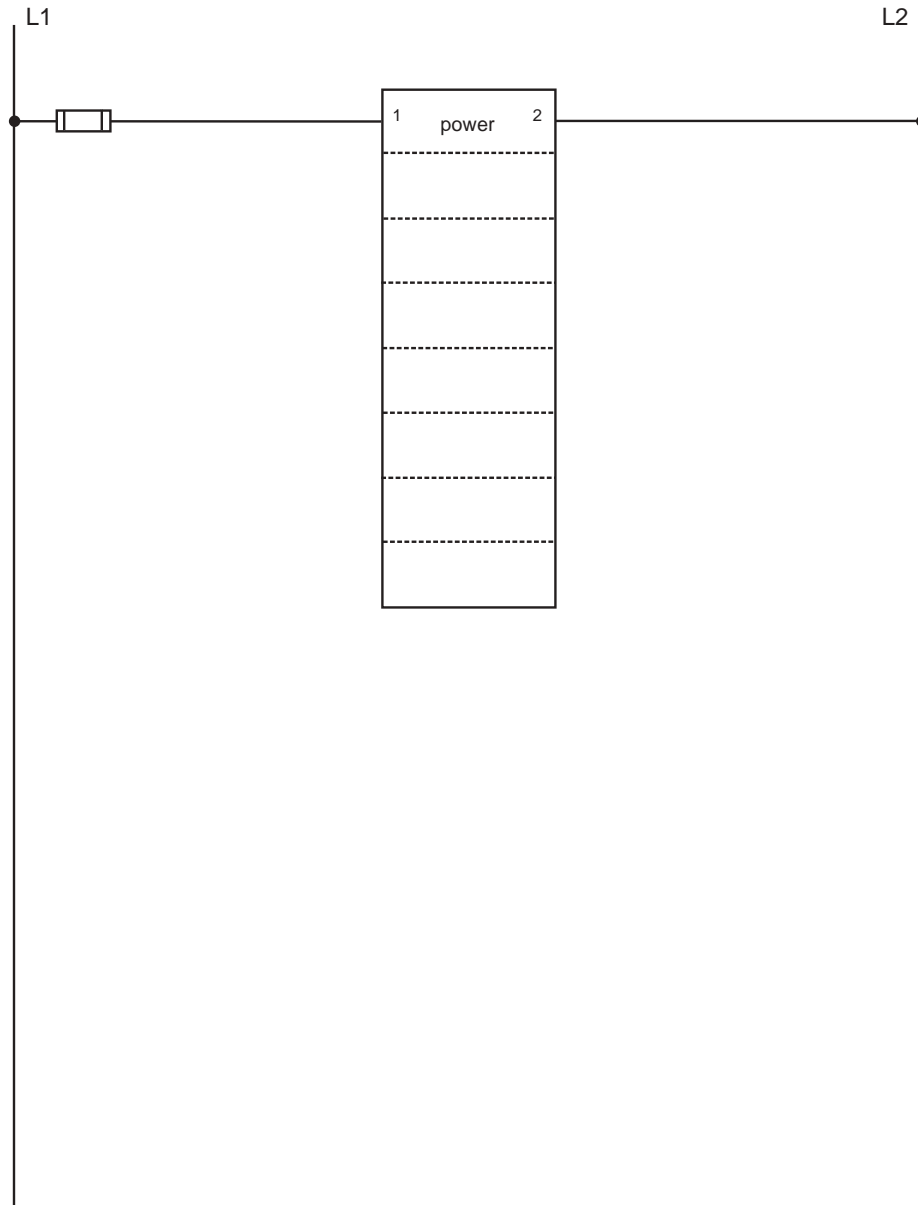

Figure 8.15 — Wiring Notes.

Notes

Chapter Nine: Communications

Exception Responses9.1
 Modbus Registers (Alphabetical Order)9.2
 Modbus Registers (Numerical Order)9.11

Overview

The Series F4P uses Modbus as its communications protocol. Modbus is a standard protocol developed by A.E.G. Schneider. Modbus RTU enables a computer or PLC to read and write directly to registers containing the controller's parameters. With it you can read all of the controller's parameters with a few read commands.

If you already have a software application that uses Modbus, the Modbus Registers Table in this chapter will provide the register number and values (sometimes called enumerated types) for each parameter.

Dependencies between parameters do exist. For best results, program the parameters in the order in which they appear in the Software Map (inside back cover).

For basic information about writing an application using Modbus protocol, you may want to download the electronic F4P Communications Guide from the Watlow web site: <http://www.watlow.com/prodtechinfo>. Search on the key words **Data Communications**.

Exception Responses

When a controller cannot process a command it returns an exception response and sets the high bit (0x80) of the command.

- 0x01 illegal command
- 0x02 illegal data address
- 0x03 illegal data value

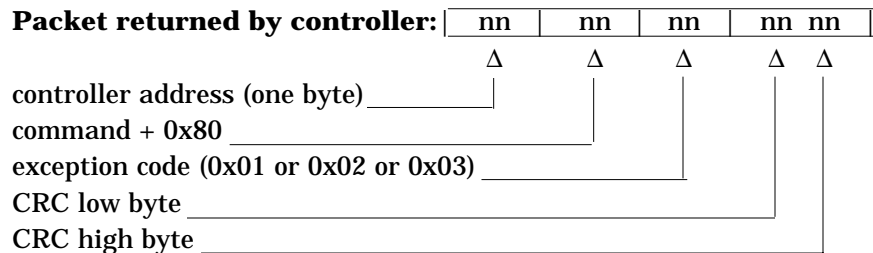

✓ **NOTE:**

For ranges, conditions and other information, look up parameter names in the Index, which will direct you to earlier chapters in this book.

Series F4P Modbus Registers

Parameters Sorted Alphabetically

A list of all Modbus registers in numerical order follows this alphabetical list. Register numbers listed are relative. Add 40001 to convert to absolute addresses. For more information about parameters, see the Index.

901	°F or °C, System	720	Alarm Hysteresis, Alarm Output 2
r/w	0 °F	r/w	1 to 9999
	1 °C	707	Alarm Logic, Alarm Output 1
103	% Power Output 1A, Status	r/w	0 Open on Alarm
r	Value		1 Close on Alarm
107	% Power Output 1B, Status	724	Alarm Logic, Alarm Output 2
r	Value	r/w	0 Open on Alarm
3050	Activate Message, Digital Input 1		1 Close on Alarm
r/w	0 Message 1	708	Alarm Messages, Alarm Output 1
	1 Message 2	r/w	0 Yes on Main Page
	2 Message 3		1 No
	3 Message 4	725	Alarm Messages, Alarm Output 2
3051	Activate Message, Digital Input 2	r/w	0 Yes on Main Page
r/w	0 Message 1		1 No
	1 Message 2	706	Alarm Sides, Alarm Output 1
	2 Message 3	r/w	0 Both
	3 Message 4		1 Low
3052	Activate Message, Digital Input 3		2 High
r/w	0 Message 1	723	Alarm Sides, Alarm Output 2
	1 Message 2	r/w	0 Both
	2 Message 3		1 Low
	3 Message 4		2 High
3053	Activate Message, Digital Input 4	716	Alarm Source, Alarm Output 1
r/w	0 Message 1	r/w	0 Input 1
	1 Message 2		1 Input 2
	2 Message 3		2 Input 3
	3 Message 4	733	Alarm Source, Alarm Output 2
303	Alarm 1 High Deviation, Alarm Set Points	r/w	0 Input 1
r/w	1 to 30000		1 Input 2
303	Alarm 1 High Set Point, Alarm Set Points		2 Input 3
r/w	<per sensor> to Alarm 1 Low Set Point	702	Alarm Type, Alarm Output 1
303	Alarm 1 Maximum High Rate, Alarm Set Points	r/w	0 Off
r/w	Alarm 1 Low Maximum Rate +1 to 30000		1 Process
302	Alarm 1 Low Deviation, Alarm Set Points		2 Deviation
r/w	-19999 to -1		3 Maximum Rate
302	Alarm 1 Low Set Point, Alarm Set Points	719	Alarm Type, Alarm Output 2
r/w	<per sensor> to Alarm 1 High Set Point	r/w	0 Off
302	Alarm 1 Maximum Low Rate, Alarm Set Points		1 Process
r/w	-19999 to Alarm 1 Maximum Rate High -1		2 Deviation
102	Alarm 1, Status		3 Maximum Rate
r	0 Off	836	Analog Range, Retransmit Output 1
	1 Alarm High	r/w	0 4 to 20mA
	2 Alarm Low		1 0 to 20mA
322	Alarm 2 High Deviation, Alarm Set Points		2 0 to 5V
r/w	1 to 30000		3 1 to 5V
322	Alarm 2 High Set Point, Alarm Set Points		4 0 to 10V
r/w	<per sensor> to Alarm 2 Low Set Point	837	Analog Range, Retransmit Output 2
322	Alarm 2 Maximum High Rate, Alarm Set Points	r/w	0 4 to 20mA
r/w	Alarm 2 Low Maximum Rate +1 to 30000		1 0 to 20mA
321	Alarm 2 Low Deviation, Alarm Set Points		2 0 to 5V
r/w	-9999 to -1		3 1 to 5V
321	Alarm 2 Low Set Point, Alarm Set Points		4 0 to 10V
r/w	<per sensor> to Alarm 2 High Set Point	200	Auto/Manual Mode, Status
321	Alarm 2 Maximum Low Rate, Alarm Set Points	r/w	1 Auto Mode
r/w	-19999 to Alarm 2 Maximum Rate High -1		2 Manual
106	Alarm 2, Status	1915	Auto/Manual Slidewire Calibration, Analog Input 3 r/w
r	0 Off	r/w	0 Skip Calibration
	1 Alarm High		1 Automatic
	2 Alarm Low		2 Manual
703	Alarm Hysteresis, Alarm Output 1	305	Autotune PID
r/w	1 to 9999	r/w	0 Tune Off

	1	PID Set 1	1611	Calibrate Process Output 1B, 1.000V
	2	PID Set 2	r/w	0 to 3000V (in thousandths)
	3	PID Set 3	1612	Calibrate Process Output 1B, 10.000V
	4	PID Set 4	r/w	0 to 12000V (in thousandths)
	5	PID Set 5	1610	Calibrate Process Output 1B, 20.000mA
307		Autotune PID Type, Autotune PID	r/w	0 to 24000mA (in thousandths)
r/w	0	Heat Only	1609	Calibrate Process Output 1B, 4.000mA
	1	Cool Only	r/w	0 to 6000mA (in thousandths)
	2	Heat and Cool	1626	Calibrate Retransmit Output 1, 1.000V
304		Autotune Set Point, System	r/w	0 to 3000V (in thousandths)
r/w		50 to 150%	1627	Calibrate Retransmit Output 1, 10.000V
884		Boost Delay Time, Control Set Points	r/w	0 to 12000V (in thousandths)
r/w		0 to 999 seconds	1625	Calibrate Retransmit Output 1, 20.000mA
881		Boost Power Mode, Control Output 1B	r/w	0 to 24000mA (in thousandths)
r/w	0	Auto Only	1624	Calibrate Retransmit Output 1, 4.000mA
	1	Auto/Manual	r/w	0 to 6000mA (in thousandths)
883		Boost Power, Control Set Points	1631	Calibrate Retransmit Output 2, 1.000V
r/w		0 to 1000% (in tenths)	r/w	0 to 3000V (in thousandths)
309		Boost Set Point (1B), Control Set Points	1632	Calibrate Retransmit Output 2, 10.000V
r/w		-19999 to 30000 [deviation]	r/w	0 to 12000V (in thousandths)
		Set Point Low Limit to Set Point High Limit [process]	1630	Calibrate Retransmit Output 2, 20.000mA
882		Boost Set Point Type, Control Output 1B	r/w	0 to 24000mA (in thousandths)
r/w	0	Process	1629	Calibrate Retransmit Output 2, 4.000mA
	1	Deviation	r/w	0 to 6000mA (in thousandths)
885		Boost Type, Control Output 1B	605	Calibration Offset Value, Analog Input 1
r/w	0	Boost on Power	r/w	Set Point Low Limit to Set Point High Limit
	1	Boost on Set Point	615	Calibration Offset Value, Analog Input 2
1603		Calibrate Input 1, Calibration	r/w	Set Point Low Limit to Set Point High Limit
r/w	1	0.00mV Thermocouple	625	Calibration Offset Value, Analog Input 3
	2	50.00mV Thermocouple	r/w	Set Point Low Limit to Set Point High Limit
	3	32°F Type J	1927	Cascade High Deviation, Analog Input 3
	4	Ground	r/w	1 to 9999
	5	Lead	1927	Cascade High Range, Analog Input 3
	6	15.0 ohms RTD	r/w	<sensor range>
	7	380.0 ohms RTD	305	Cascade Inner Loop, Autotune PID Set
	8	0.000V	r/w	0 Tune Off
	9	10.000V		1 PID Set 1
	10	4.000mA		2 PID Set 2
	11	20.000mA		3 PID Set 3
1608		Calibrate Input 2, Calibration		4 PID Set 4
r/w	1	0.00mV Thermocouple		5 PID Set 5
	2	50.00mV Thermocouple	1922	Cascade Internal Set Point
	3	32°F Type J	r	
	4	Ground	1926	Cascade Low Deviation, Analog Input 3
	5	Lead	r/w	-19999 to -1
	6	15.0 ohms RTD	1926	Cascade Low Range, Analog Input 3
	7	380.0 ohms RTD	r/w	<sensor range>
	8	0.000V	1925	Cascade, Analog Input 3
	9	10.000V	r/w	0 Process Cascade
	10	4.000mA		1 Deviation Cascade
	11	20.000mA	343	Cascade Outer Loop, Autotune PID Set
1613		Calibrate Input 3, Calibration	r/w	0 Tune Off
r/w	1	0.00mV Thermocouple		1 PID Set 1
	2	50.00mV Thermocouple		2 PID Set 2
	3	32°F Type J		3 PID Set 3
	4	Ground		4 PID Set 4
	5	Lead		5 PID Set 5
	6	15.0 ohms RTD	1501	CJC1 AtoD, Diagnostic
	7	380.0 ohms RTD	r	HHHH see In 1 AD
	8	0.000V	1500	CJC1 Temp, Diagnostic
	9	10.000V	r	xx.x
	10	4.000mA	1532	CJC2-CJC3 AtoD, Diagnostic
	11	20.000mA	r	HHHH see In 1 AD
	12	15.0 ohms Slidewire (F4P_-- AB-___ models only)	1531	CJC2-CJC3 Temp, Diagnostic
	13	1000.0 ohms Slidewire (F4P_-- AB-___ models only)	r	xx.x
1606		Calibrate Process Output 1A, 1.000V	312	Clear Alarm 1, Key Press Simulation
r/w		0 to 3000V (in thousandths)	w	write any value
1607		Calibrate Process Output 1A, 10.000V	331	Clear Alarm 2, Key Press Simulation
r/w		0 to 12000V (in thousandths)	w	write any value
1605		Calibrate Process Output 1A, 20.000mA	311	Clear Error Input 1, Key Press Simulation
r/w		0 to 24000mA (in thousandths)		
1604		Calibrate Process Output 1A, 4.000mA		
r/w		0 to 6000mA (in thousandths)		

✓NOTE:
For more information about parameters, see the Index.

w	write any value		1	Fixed Time
330	Clear Error Input 2, Key Press Simulation		506	Cycle Time, Control Output 1A
w	write any value		r/w	1 to 600 in tenths
349	Clear Error Input 3, Key Press Simulation		556	Cycle Time, Control Output 1B
w	write any value		r/w	1 to 600 in tenths
5566	Clear Input 1 Offsets, Analog Input 1		2605	Dead Band 1A, Cascade PID Set 1
r/w	0 No		r/w	0 to 30000
	1 Yes		2625	Dead Band 1A, Cascade PID Set 2
5567	Clear Input 2 Offsets, Analog Input 2		r/w	0 to 30000
r/w	0 No		2645	Dead Band 1A, Cascade PID Set 3
	1 Yes		r/w	0 to 30000
5568	Clear Input 3 Offsets, Analog Input 3		2665	Dead Band 1A, Cascade PID Set 4
r/w	0 No		r/w	0 to 30000
	1 Yes		2685	Dead Band 1A, Cascade PID Set 5
1315	Clear Locks, Set Lockout		r/w	0 to 30000
w	0 Yes		505	Dead Band 1A, PID Set 1
1061	Condition, Digital Input 1		r/w	0 to 30000
r/w	0 Low		515	Dead Band 1A, PID Set 2
	1 High		r/w	0 to 30000
1063	Condition, Digital Input 2		525	Dead Band 1A, PID Set 3
r/w	0 Low		r/w	0 to 30000
	1 High		535	Dead Band 1A, PID Set 4
1065	Condition, Digital Input 3		r/w	0 to 30000
r/w	0 Low		545	Dead Band 1A, PID Set 5
	1 High		r/w	0 to 30000
1067	Condition, Digital Input 4		2615	Dead Band 1B, Cascade PID Set 1
r/w	0 Low		r/w	0 to 30000
	1 High		2635	Dead Band 1B, Cascade PID Set 2
298	Control Set Point		r/w	0 to 30000
r			2655	Dead Band 1B, Cascade PID Set 3
1140	Control Type, Analog Input 2		r/w	0 to 30000
r/w	0 Normal		2675	Dead Band 1B, Cascade PID Set 4
	3 Remote		r/w	0 to 30000
	4 Alternate		2695	Dead Band 1B, Cascade PID Set 5
1141	Control Type, Analog Input 3		r/w	0 to 30000
r/w	0 Normal		555	Dead Band 1B, PID Set 1
	1 Ratio		r/w	0 to 30000
	2 Differential		565	Dead Band 1B, PID Set 2
	3 Remote		r/w	0 to 30000
	5 Cascade		575	Dead Band 1B, PID Set 3
1400-15	Custom Main Page Parameters (P1 to P16)		r/w	0 to 30000
r/w	0 None		585	Dead Band 1B, PID Set 4
	1 Input 1		r/w	0 to 30000
	2 Input 1 Value Bar		595	Dead Band 1B, PID Set 5
	3 Input 2		r/w	0 to 30000
	4 Input 2 Value Bar		606	Decimal, Analog Input 1
	5 Input 3		r/w	0 0
	6 Input 3 Value Bar			1 0.0
	7 Digital Set Point			2 0.00 (process)
	8 Digital Differential Value			3 0.000 (process)
	9 Differential Set Point		616	Decimal, Analog Input 2
	10 Set Differential		r/w	0 0
	11 Digital Ratio Value			1 0.0
	12 Ratio Set Point			2 0.00 (process)
	13 Set Ratio			3 0.000 (process)
	14 Remote Set Point 2		626	Decimal, Analog Input 3
	15 Remote Set Point 3		r/w	0 0
	16 Target Set Point			1 0.0
	17 Inner Set Point			2 0.00 (process)
	18 Set Point 1			3 0.000 (process)
	19 Set Point 1 Bar		2603	Derivative 1A, Cascade PID Set 1
	20 % Power 1A		r/w	0 to 999 minutes (in hundredths)
	21 % Power 1B		2623	Derivative 1A, Cascade PID Set 2
	22 % Power 1A Bar		r/w	0 to 999 minutes (in hundredths)
	23 % Power 1B Bar		2643	Derivative 1A, Cascade PID Set 3
	24 Tune Status 1		r/w	0 to 999 minutes (in hundredths)
	25 Digital Inputs		2663	Derivative 1A, Cascade PID Set 4
	26 Active Ch1 PID Set		r/w	0 to 999 minutes (in hundredths)
509	Cycle Time Type, Control Output 1A		2683	Derivative 1A, Cascade PID Set 5
r/w	0 Variable Burst		r/w	0 to 999 minutes (in hundredths)
	1 Fixed Time			
559	Cycle Time Type, Control Output 1B			
r/w	0 Variable Burst			

503	Derivative 1A, PID Set 1	1	On
r/w	0 to 999 minutes (in hundredths)		
513	Derivative 1A, PID Set 2	607	Error Latch, Analog Input 1
r/w	0 to 999 minutes (in hundredths)	r/w	0 Self Clear
523	Derivative 1A, PID Set 3	1	Latch
r/w	0 to 999 minutes (in hundredths)		
533	Derivative 1A, PID Set 4	617	Error Latch, Analog Input 2
r/w	0 to 999 minutes (in hundredths)	r/w	0 Self Clear
543	Derivative 1A, PID Set 5	1	Latch
r/w	0 to 999 minutes (in hundredths)		
2613	Derivative 1B, Cascade PID Set 1	627	Error Latch, Analog Input 3
r/w	0 to 999 minutes (in hundredths)	r/w	0 Self Clear
2633	Derivative 1B, Cascade PID Set 2	1	Latch
r/w	0 to 999 minutes (in hundredths)		
2653	Derivative 1B, Cascade PID Set 3	1303	Factory Page, Set Lockout
r/w	0 to 999 minutes (in hundredths)	r/w	0 Full Access
2673	Derivative 1B, Cascade PID Set 4	1	Read Only
r/w	0 to 999 minutes (in hundredths)	2	Password
2693	Derivative 1B, Cascade PID Set 5	880	Failure Mode, System
r/w	0 to 999 minutes (in hundredths)	r/w	0 Bumpless Transfer
553	Derivative 1B, PID Set 1	1	Fixed
r/w	0 to 999 minutes (in hundredths)		
563	Derivative 1B, PID Set 2	604	Filter Time, Analog Input 1
r/w	0 to 999 minutes (in hundredths)	r/w	-60.0 to 60.0
573	Derivative 1B, PID Set 3	614	Filter Time, Analog Input 2
r/w	0 to 999 minutes (in hundredths)	r/w	-60.0 to 60.0
583	Derivative 1B, PID Set 4	624	Filter Time, Analog Input 3
r/w	0 to 999 minutes (in hundredths)	r/w	-60.0 to 60.0
593	Derivative 1B, PID Set 5	1602	Full Defaults, Test
r/w	0 to 999 minutes (in hundredths)	w	0 yes
314	Digital Differential Set Point 1, Control Set Points	700	Function, Control Output 1A
r/w	-19999 to 30000	r/w	0 Off
333	Digital Differential Set Point 2, Control Set Points	1	Heat [reverse]
r/w	-19999 to 30000	2	Cool [direct]
352	Digital Differential Set Point 3, Control Set Points	717	Function, Control Output 1B
r/w	-19999 to 30000	r/w	0 Off
371	Digital Differential Set Point 4, Control Set Points	1	Heat [reverse]
r/w	-19999 to 30000	2	Cool [direct]
201	Digital Input 1, Status	1060	Function, Digital Input 1
r	0 Low	r/w	0 Off
	1 High	1	Panel Lock
213	Digital Input 2, Status	2	Reset Alarm 1
r	0 Low	3	Reset Alarm 2
	1 High	4	Reset Both Alarms
225	Digital Input 3, Status	5	Control Outputs Off
r	0 Low	6	Digital Set Point
	1 High	7	Differential Set Point
237	Digital Input 4, Status	8	Digital Ratio
r	0 Low	9	Remote 2
	1 High	10	Remote 3
315	Digital Ratio Set Point 1, Control Set Points	11	Alternate Control
r/w	0% to 30000%	12	Manual Control
334	Digital Ratio Set Point 2, Control Set Points	13	Reverse Outputs
r/w	0% to 30000%	14	Activate Messages
353	Digital Ratio Set Point 3, Control Set Points	15	Lock Auto/Man
r/w	0% to 30000%		
372	Digital Ratio Set Point 4, Control Set Points	1062	Function, Digital Input 2
r/w	0% to 30000%	r/w	0 Off
308	Digital Set Point 1, Control Set Points	1	Panel Lock
r/w	Set Point Low Limit to Set Point High Limit	2	Reset Alarm 1
327	Digital Set Point 2, Control Set Points	3	Reset Alarm 2
r/w	Set Point Low Limit to Set Point High Limit	4	Reset Both Alarms
346	Digital Set Point 3	5	Control Outputs Off
r/w	Set Point Low Limit to Set Point High Limit	6	Digital Set Point
365	Digital Set Point 4, Control Set Points	7	Differential Set Point
r/w	Set Point Low Limit to Set Point High Limit	8	Digital Ratio
1513	Display Test, Test	9	Remote 2
w	1 Perform Display Test	10	Remote 3
844	Duplex Output, Control Output 1A	11	Alternate Control
r/w	0 Off	12	Manual Control
		13	Reverse Outputs
		14	Activate Messages
		15	Lock Auto/Man
		1064	Function, Digital Input 3
		r/w	0 Off
		1	Panel Lock
		2	Reset Alarm 1
		3	Reset Alarm 2
		4	Reset Both Alarms
		5	Control Outputs Off

✓ **NOTE:**
For more information about parameters, see the Index.

	6	Digital Set Point	587	Hysteresis 1B, PID Set 4
	7	Differential Set Point	r/w	1 to 30000
	8	Digital Ratio	597	Hysteresis 1B, PID Set 5
	9	Remote 2	r/w	1 to 30000
	10	Remote 3	1504	Input 1 AtoD, Diagnostic
	11	Alternate Control	r	HHHH
	12	Manual Control	101	Input 1 Error, Status
	13	Reverse Outputs	r	0 None
	14	Activate Messages		1 AtoD Under Flow
	15	Lock Auto/Man		2 Sensor Under Range
1066	Function, Digital Input 4			3 Sensor Over Range
r/w	0	Off		4 AtoD Over Flow
	1	Panel Lock		5 AtoD Timeout
	2	Reset Alarm 1		6 Open Loop
	3	Reset Alarm 2	903	Input 1 Failure, System
	4	Reset Both Alarms	r/w	0% to High Power Limit (heat only or cool only)
	5	Control Outputs Off		Cool High Power Limit to Heat High Power Limit
	6	Digital Set Point		(heat/cool or cool/heat)
	7	Differential Set Point	210	Input 1 Open Loop, Status
	8	Digital Ratio	r	(0) Off, (1) On
	9	Remote 2	100	Input 1 Value, Status
	10	Remote 3	r	xx
	11	Alternate Control	8	Input 1, Diagnostic
	12	Manual Control	r	0 None
	13	Reverse Outputs		8 Univ
	14	Activate Messages	1505	Input 2 AtoD, Diagnostic
	15	Lock Auto/Man	r	HHHH
714	High Power Limit, Control Output 1A		9	Input 2, Diagnostic
r/w	Low Limit+1 to 100%		r	0 None
731	High Power Limit, Control Output 1B			8 Univ
r/w	Low Limit+1 to 100%		1506	Input 3 AtoD, Diagnostic
711	High Scale, Retransmit Output 1		r	HHHH
r/w	-19999 to 30000 (maximum sensor range)		10	Input 3, Diagnostic
728	High Scale, Retransmit Output 2		r	Univ
r/w	-19999 to 30000 (maximum sensor range)		2601	Integral 1A, Cascade PID Set 1
2607	Hysteresis 1A, Cascade PID Set 1		r/w	0 to 9999 minutes in hundredths
r/w	1 to 30000		2621	Integral 1A, Cascade PID Set 2
2627	Hysteresis 1A, Cascade PID Set 2		r/w	0 to 9999 minutes in hundredths
r/w	1 to 30000		2641	Integral 1A, Cascade PID Set 3
2647	Hysteresis 1A, Cascade PID Set 3		r/w	0 to 9999 minutes in hundredths
r/w	1 to 30000		2661	Integral 1A, Cascade PID Set 4
2667	Hysteresis 1A, Cascade PID Set 4		r/w	0 to 9999 minutes in hundredths
r/w	1 to 30000		2681	Integral 1A, Cascade PID Set 5
2687	Hysteresis 1A, Cascade PID Set 5		r/w	0 to 9999 minutes in hundredths
r/w	1 to 30000		501	Integral 1A, PID Set 1
507	Hysteresis 1A, PID Set 1		r/w	0 to 9999 minutes in hundredths
r/w	1 to 30000		511	Integral 1A, PID Set 2
517	Hysteresis 1A, PID Set 2		r/w	0 to 9999 minutes in hundredths
r/w	1 to 30000		521	Integral 1A, PID Set 3
527	Hysteresis 1A, PID Set 3		r/w	0 to 9999 minutes in hundredths
r/w	1 to 30000		531	Integral 1A, PID Set 4
537	Hysteresis 1A, PID Set 4		r/w	0 to 9999 minutes in hundredths
r/w	1 to 30000		541	Integral 1A, PID Set 5
547	Hysteresis 1A, PID Set 5		r/w	0 to 9999 minutes in hundredths
r/w	1 to 30000		2611	Integral 1B, Cascade PID Set 1
2617	Hysteresis 1B, Cascade PID Set 1		r/w	0 to 9999 minutes in hundredths
r/w	1 to 30000		2631	Integral 1B, Cascade PID Set 2
2637	Hysteresis 1B, Cascade PID Set 2		r/w	0 to 9999 minutes in hundredths
r/w	1 to 30000		2651	Integral 1B, Cascade PID Set 3
2657	Hysteresis 1B, Cascade PID Set 3		r/w	0 to 9999 minutes in hundredths
r/w	1 to 30000		2671	Integral 1B, Cascade PID Set 4
2677	Hysteresis 1B, Cascade PID Set 4		r/w	0 to 9999 minutes in hundredths
r/w	1 to 30000		2691	Integral 1B, Cascade PID Set 5
2697	Hysteresis 1B, Cascade PID Set 5		r/w	0 to 9999 minutes in hundredths
r/w	1 to 30000		551	Integral 1B, PID Set 1
557	Hysteresis 1B, PID Set 1		r/w	0 to 9999 minutes in hundredths
r/w	1 to 30000		561	Integral 1B, PID Set 2
567	Hysteresis 1B, PID Set 2		r/w	0 to 9999 minutes in hundredths
r/w	1 to 30000		571	Integral 1B, PID Set 3
577	Hysteresis 1B, PID Set 3		r/w	0 to 9999 minutes in hundredths
r/w	1 to 30000			

581	Integral 1B, PID Set 4	r/w	0 to 9999 minutes in hundredths	r/w	ASCII codes A to Z, 0 to 9, space
591	Integral 1B, PID Set 5	r/w	0 to 9999 minutes in hundredths	5506-15	Offset Point 01-10, Analog Input 1, rw
704	Latching, Alarm Output 1	r/w	0 Alarm Self-clears 1 Alarm Latches	r/w	-19999 or Input Offset (x-1) Value + 1 to Input Offset (x+1) Value - 1 or 30000
721	Latching, Alarm Output 2	r/w	0 Alarm Self-clears 1 Alarm Latches	5516-25	Offset Point 01-10, Analog Input 2, r/w
1914	LED Intensity, Process Display	r/w	0 to 15	r/w	-19999 or Input Offset (x-1) Value + 1 to Input Offset (x+1) Value - 1 or 30000
1515	Line Frequency, Diagnostic	r	xx	5526-35	Offset Point 01-10, Analog Input 3, r/w
715	Low Power Limit, Control Output 1A	r/w	0% to High Limit-1	r/w	-19999 or Input Offset (x-1) Value + 1 to Input Offset (x+1) Value - 1 or 30000
732	Low Power Limit, Control Output 1B	r/w	0% to High Limit-1	5572	Offset Type, Analog Input 1
710	Low Scale, Retransmit Output 1	r/w	-19999 to 30000 (minimum sensor range)	r/w	0 Single Linear 1 Multiple Point
727	Low Scale, Retransmit Output 2	r/w	-19999 to 30000 (minimum sensor range)	5573	Offset Type, Analog Input 2
454	Manual to Auto Transfer, System	r/w	0 Restore Set Point 1 Reverse Bumpless	r/w	0 Single Linear 1 Multiple Point
5	Manufacturing Date, Diagnostic	r	xxxx	5574	Offset Type, Analog Input 3
453	Maximum Transfer Cool, System	r/w	-100% to 0%	r/w	0 Single Linear 1 Multiple Point
452	Maximum Transfer Heat, System	r/w	0% to 100%	5536-45	Offset Value 01-10, Analog Input 1
4501-17	Message 1 (Line 01, Char 01-17), Static Message	r/w		r/w	-1000 to 1000
4521-37	Message 1 (Line 02, Char 01-17), Static Message	r/w		5546-55	Offset Value 01-10, Analog Input 2
4541-57	Message 1 (Line 03, Char 01-17), Static Message	r/w		r/w	-1000 to 1000
4561-77	Message 1 (Line 04, Char 01-17), Static Message	r/w		5556-65	Offset Value 01-10, Analog Input 3
4581-97	Message 2 (Line 01, Char 01-17), Static Message	r/w		r/w	-1000 to 1000
4601-17	Message 2 (Line 02, Char 01-17), Static Message	r/w		904	Open Loop Detect, System
4621-37	Message 2 (Line 03, Char 01-17), Static Message	r/w		r/w	0 Off 1 On
4641-57	Message 2 (Line 04, Char 01-17), Static Message	r/w		1308	Operations, Alarm Set Point, Set Lockout
4661-77	Message 3 (Line 01, Char 01-17), Static Message	r/w		r/w	0 Full Access 1 Read Only 2 Password 3 Hidden
4681-97	Message 3 (Line 02, Char 01-17), Static Message	r/w		1306	Operations, Autotune PID, Set Lockout/rw
4701-17	Message 3 (Line 03, Char 01-17), Static Message	r/w		r/w	0 Full Access 1 Read Only 2 Password 3 Hidden
4721-37	Message 3 (Line 04, Char 01-17), Static Message	r/w		1318	Operations, Control Set Point, Set Lockout
4741-57	Message 4 (Line 01, Char 01-17), Static Message	r/w		r/w	0 Full Access 1 Read Only 2 Password 3 Hidden
4761-77	Message 4 (Line 02, Char 01-17), Static Message	r/w		1307	Operations, Edit PID, Set Lockout
4781-97	Message 4 (Line 03, Char 01-17), Static Message	r/w		r/w	0 Full Access 1 Read Only 2 Password 3 Hidden
4801-17	Message 4 (Line 04, Char 01-17), Static Message	r/w		200	Operations Mode, Status
3060	Message Display Time, Digital Input 1	r/w	0 to 999	r/w	1 Auto Mode 2 Manual
3061	Message Display Time, Digital Input 2	r/w	0 to 999	1316	Operations, PID Crossover, Set Lockout
3062	Message Display Time, Digital Input 3	r/w	0 to 999	r/w	0 Full Access 1 Read Only 2 Password 3 Hidden
3063	Message Display Time, Digital Input 4	r/w	0 to 999	1317	Operations, Ramp Set Point, Set Lockout
0	Model, Diagnostic	r	5280 4P	r/w	0 Full Access 1 Read Only 2 Password 3 Hidden
3200-09	Name (Char 01-10), Alarm Output 1	r/w	ASCII codes A to Z, 0 to 9, space	1319	Operations, Remote Set Point, Set Lockout
3210-19	Name (Char 01-10), Alarm Output 2	r/w	ASCII codes A to Z, 0 to 9, space	r/w	0 Full Access 1 Read Only 2 Password 3 Hidden
3000-06	Name (Char 01-07), Digital Input 1	r/w	ASCII codes A to Z, 0 to 9, space	16	Output 1A, Diagnostic
3010-16	Name (Char 01-07), Digital Input 2	r/w	ASCII codes A to Z, 0 to 9, space	r	0 None 1 Mechanical Relay 2 SSR 3 DC 4 Process
3020-26	Name (Char 01-07), Digital Input 3	r/w	ASCII codes A to Z, 0 to 9, space		
3030-36	Name (Char 01-07), Digital Input 4	r/w	ASCII codes A to Z, 0 to 9, space		

17	Output 1B, Diagnostic	2670	Proportional Band 1B, Cascade PID Set 4
r	0 None	r/w	0 to 30000
	1 Mechanical Relay	2690	Proportional Band 1B, Cascade PID Set 5
	2 SSR	r/w	0 to 30000
	3 DC	550	Proportional Band 1B, PID Set 1
	4 Process	r/w	0 to 30000
1961	PID Cross 1-2, Operations	560	Proportional Band 1B, PID Set 2
r/w	-19999 to 30000	r/w	0 to 30000
1962	PID Cross 2-3, Operations	570	Proportional Band 1B, PID Set 3
r/w	-19999 to 30000	r/w	0 to 30000
1963	PID Cross 3-4, Operations	580	Proportional Band 1B, PID Set 4
r/w	-19999 to 30000	r/w	0 to 30000
1964	PID Cross 4-5, Operations	590	Proportional Band 1B, PID Set 5
r/w	-19999 to 30000	r/w	0 to 30000
1951	PID Crossover, Operations	1100	Ramp to Set Point Mode, Operations
r	0 Off	r/w	0 Off
	1 Process		1 Startup
	2 Set Point		2 Startup or Change
900	PID Units, System	1101	Ramp to Set Point Rate, Operations
r/w	0 US (Reset/Rate)	r/w	1 to 999 degrees or units per minute or hour
	1 SI (Integral/Derivative)	1102	Ramp to Set Point Scale, Ramp to Set Point
1910	Process Display	r/w	0 Degrees per Minute
r/w	0 Input 1		1 Degrees per Hour
	1 Alternating	2604	Rate 1A, Cascade PID Set 1
1911	Process Display Time, Input 1	r/w	0 to 999 minutes (in hundredths)
r/w	0 to 999 seconds	2624	Rate 1A, Cascade PID Set 2
1912	Process Display Time, Input 2	r/w	0 to 999 minutes (in hundredths)
r/w	0 to 999 seconds	2644	Rate 1A, Cascade PID Set 3
1913	Process Display Time, Input 3	r/w	0 to 999 minutes (in hundredths)
r/w	0 to 999 seconds	2664	Rate 1A, Cascade PID Set 4
701	Process, Control Output 1A	r/w	0 to 999 minutes (in hundredths)
r/w	0 4 to 20mA	2684	Rate 1A, Cascade PID Set 5
	1 0 to 20mA	r/w	0 to 999 minutes (in hundredths)
	2 0 to 5V	504	Rate 1A, PID Set 1
	3 1 to 5V	r/w	0 to 999 minutes (in hundredths)
	4 0 to 10V	514	Rate 1A, PID Set 2
	5 20 to 4mA [reverse value]	r/w	0 to 999 minutes (in hundredths)
718	Process, Control Output 1B	524	Rate 1A, PID Set 3
r/w	0 4 to 20mA	r/w	0 to 999 minutes (in hundredths)
	1 0 to 20mA	534	Rate 1A, PID Set 4
	2 0 to 5V	r/w	0 to 999 minutes (in hundredths)
	3 1 to 5V	544	Rate 1A, PID Set 5
	4 0 to 10V	r/w	0 to 999 minutes (in hundredths)
	5 20 to 4mA [reverse value]	2614	Rate 1B, Cascade PID Set 1
2600	Proportional Band 1A, Cascade PID Set 1	r/w	0 to 999 minutes (in hundredths)
r/w	0 to 30000	2634	Rate 1B, Cascade PID Set 2
2620	Proportional Band 1A, Cascade PID Set 2	r/w	0 to 999 minutes (in hundredths)
r/w	0 to 30000	2654	Rate 1B, Cascade PID Set 3
2640	Proportional Band 1A, Cascade PID Set 3	r/w	0 to 999 minutes (in hundredths)
r/w	0 to 30000	2674	Rate 1B, Cascade PID Set 4
2660	Proportional Band 1A, Cascade PID Set 4	r/w	0 to 999 minutes (in hundredths)
r/w	0 to 30000	2694	Rate 1B, Cascade PID Set 5
2680	Proportional Band 1A, Cascade PID Set 5	r/w	0 to 999 minutes (in hundredths)
r/w	0 to 30000	554	Rate 1B, PID Set 1
500	Proportional Band 1A, PID Set 1	r/w	0 to 999 minutes (in hundredths)
r/w	0 to 30000	564	Rate 1B, PID Set 2
510	Proportional Band 1A, PID Set 2	r/w	0 to 999 minutes (in hundredths)
r/w	0 to 30000	574	Rate 1B, PID Set 3
520	Proportional Band 1A, PID Set 3	r/w	0 to 999 minutes (in hundredths)
r/w	0 to 30000	584	Rate 1B, PID Set 4
530	Proportional Band 1A, PID Set 4	r/w	0 to 999 minutes (in hundredths)
r/w	0 to 30000	594	Rate 1B, PID Set 5
540	Proportional Band 1A, PID Set 5	r/w	0 to 999 minutes (in hundredths)
r/w	0 to 30000	316	Remote/Local Set Point, Local/Remote Set Point
2610	Proportional Band 1B, Cascade PID Set 1	r/w	0 Local Set Point
r/w	0 to 30000		1 Remote 2
2630	Proportional Band 1B, Cascade PID Set 2		2 Remote 3
rr/w	0 to 30000	2602	Reset 1A, Cascade PID Set 1
2650	Proportional Band 1B, Cascade PID Set 3	r/w	0 to 9999 repeats per minute (in hundredths)
r/w	0 to 30000		

2622	Reset 1A, Cascade PID Set 2	685	Scale High, Analog Input 3
r/w	0 to 9999 repeats per minute (in hundredths)	r/w	Depends on sensor and decimal point selection.
2642	Reset 1A, Cascade PID Set 3	680	Scale Low, Analog Input 1
r/w	0 to 9999 repeats per minute (in hundredths)	r/w	Depends on sensor and decimal point selection.
2662	Reset 1A, Cascade PID Set 4	682	Scale Low, Analog Input 2
r/w	0 to 9999 repeats per minute (in hundredths)	r/w	Depends on sensor and decimal point selection.
2682	Reset 1A, Cascade PID Set 5	684	Scale Low, Analog Input 3
r/w	0 to 9999 repeats per minute (in hundredths)	r/w	Depends on sensor and decimal point selection.
502	Reset 1A, PID Set 1	712	Scale Offset, Retransmit Output 1
r/w	0 to 9999 repeats per minute (in hundredths)	r/w	-9999 to 9999
512	Reset 1A, PID Set 2		Range Low to Range High
r/w	0 to 9999 repeats per minute (in hundredths)	729	Scale Offset, Retransmit Output 2
522	Reset 1A, PID Set 3	r/w	-9999 to 9999
r/w	0 to 9999 repeats per minute (in hundredths)		Range Low to Range High
532	Reset 1A, PID Set 4	693	Scaling, Input 1
r/w	0 to 9999 repeats per minute (in hundredths)	r/w	0 Normal Scaling
542	Reset 1A, PID Set 5		1 Inverse Scaling
r/w	0 to 9999 repeats per minute (in hundredths)	694	Scaling, Input 2
2612	Reset 1B, Cascade PID Set 1	r/w	0 Normal Scaling
r/w	0 to 9999 repeats per minute (in hundredths)		1 Inverse Scaling
2632	Reset 1B, Cascade PID Set 2	695	Scaling, Input 3
r/w	0 to 9999 repeats per minute (in hundredths)	r/w	0 Normal Scaling
2652	Reset 1B, Cascade PID Set 3		1 Inverse Scaling
r/w	0 to 9999 repeats per minute (in hundredths)	600	Sensor, Analog Input 1
2672	Reset 1B, Cascade PID Set 4	r/w	0 Thermocouple
r/w	0 to 9999 repeats per minute (in hundredths)		1 RTD
2692	Reset 1B, Cascade PID Set 5		2 Process
r/w	0 to 9999 repeats per minute (in hundredths)	610	Sensor, Analog Input 2
552	Reset 1B, PID Set 1	r/w	0 Thermocouple
r/w	0 to 9999 repeats per minute (in hundredths)		1 RTD
562	Reset 1B, PID Set 2		2 Process
r/w	0 to 9999 repeats per minute (in hundredths)		4 Off
572	Reset 1B, PID Set 3	620	Sensor, Analog Input 3
r/w	0 to 9999 repeats per minute (in hundredths)	r/w	0 Thermocouple
582	Reset 1B, PID Set 4		1 RTD
r/w	0 to 9999 repeats per minute (in hundredths)		2 Process
592	Reset 1B, PID Set 5		3 Slidewire
r/w	0 to 9999 repeats per minute (in hundredths)		4 Off
1601	Restore Calibration, Inputs 1-3	1	Serial Number (first part), Diagnostic
w	0 Yes (Input 1)	r	000000 to 999999
	1 Yes (Input 2)	2	Serial Number (second part), Diagnostic
	2 Yes (Input 3)	r	000000 to 999999
20	Retransmit 1, Diagnostic	299	Set Differential Value
r	0 None	r/w	-19999 to 30000
	4 Process	300	Set Point 1, Main Page
21	Retransmit 2, Diagnostic	r/w	Value
r	0 None	603	Set Point High Limit, Analog Input 1
	4 Process	r/w	Depends on Sensor
709	Retransmit Source, Retransmit Output 1	613	Set Point High Limit, Analog Input 2
r/w	0 Off	r/w	Depends on Sensor
	1 Input 1	623	Set Point High Limit, Analog Input 3
	2 Input 2	r/w	Depends on Sensor
	3 Input 3	602	Set Point Low Limit, Analog Input 1
	4 Set Point	r/w	Depends on Sensor
	5 Channel 1 Power	612	Set Point Low Limit, Analog Input 2
726	Retransmit Source, Retransmit Output 2	r/w	Depends on Sensor
r/w	0 Off	622	Set Point Low Limit, Analog Input 3
	1 Input 1	r/w	Depends on Sensor
	2 Input 2	1300	Set Point, Set Lockout
	3 Input 3	r/w	0 Full Access
	4 Set Point		1 Read Only
	5 Channel 1 Power	301	Set Ratio Value
4	Revision, Diagnostic	r/w	
r	0.00 to 9.99	1330-33	Set/Change Password, Set Lockout
25	Save Changes to EE	r/w	Four characters, ASCII codes 0-9, A-Z
w	0 Save	1302	Setup Page, Set Lockout
681	Scale High, Analog Input 1	r/w	0 Full Access
r/w	Depends on sensor and decimal point selection.		1 Read Only
683	Scale High, Analog Input 2		2 Password
r/w	Depends on sensor and decimal point selection.		3 Hidden

1923 Show °F or °C, System
 r/w 0 No, Upper Display
 1 Yes, Upper Display
313 Silence Alarm 1, Key Press Simulation
 w 0 to 9999
332 Silence Alarm 2, Key Press Simulation
 w 0 to 9999
705 Silencing, Alarm Output 1
 r/w 0 No
 1 Yes
722 Silencing, Alarm Output 2
 r/w 0 No
 1 Yes
1916 Slidewire Deadband, Analog Input 3
 r/w 3 to 1000% (in tenths)
1917 Slidewire Hysteresis, Analog Input 3
 r/w 0 to 1000% (in tenths)
1918 Slidewire Learn Closed, Analog Input 3
 r/w (Close the valve manually.)
1919 Slidewire Learn Open, Analog Input 3
 r/w (Open the valve manually.)
3 Software Number, Diagnostic
 r 00 to 99
5569 Square Root, Analog Input 1
 r/w 0 Off
 1 On
5570 Square Root, Analog Input 2
 r/w 0 Off
 1 On
5571 Square Root, Analog Input 3
 r/w 0 Off
 1 On
1514 Test Outputs, Test
 w 0 All Off
 1 Output 1A
 2 Output 1B
 5 Retransmit 1
 6 Retransmit 2
 7 Alarm 1
 8 Alarm 2
 9 All On
 10 Communications
601 Sensor Type, Analog Input 1
 r/w 0 J
 1 K
 2 T
 3 E
 4 N
 5 C
 6 D
 7 PT2
 8 R
 9 S
 10 B
 11 DIN 100Ω RTD
 12 JIS 100Ω RTD
 13 4 to 20mA
 14 0 to 20mA
 15 0 to 5V
 16 1 to 5V
 17 0 to 10V
 18 0 to 50mV
 23 DIN 500Ω RTD
 24 JIS 500Ω RTD
 25 DIN 1kΩ RTD
 26 JIS 1kΩ RTD

611 Sensor Type, Analog Input 2
 r/w 0 J
 1 K
 2 T
 3 E
 4 N
 5 C
 6 D
 7 PT2
 8 R
 9 S
 10 B
 11 DIN 100Ω RTD
 12 JIS 100Ω RTD
 13 4 to 20mA
 14 0 to 20mA
 15 0 to 5V
 16 1 to 5V
 17 0 to 10V
 18 0 to 50mV
 23 DIN 500Ω RTD
 24 JIS 500Ω RTD
 25 DIN 1kΩ RTD
 26 JIS 1kΩ RTD

621 Sensor Type, Analog Input 3
 r/w 0 J
 1 K
 2 T
 3 E
 4 N
 5 C
 6 D
 7 PT2
 8 R
 9 S
 10 B
 11 DIN 100Ω RTD
 12 JIS 100Ω RTD
 13 4 to 20mA
 14 0 to 20mA
 15 0 to 5V
 16 1 to 5V
 17 0 to 10V
 18 0 to 50mV
 19 Slidewire
 23 DIN 500Ω RTD
 24 JIS 500Ω RTD
 25 DIN 1kΩ RTD
 26 JIS 1kΩ RTD

3070-72 Units (Char 1-3), Analog Input 1
 r/w ASCII codes 0-9, A-Z, space

3073-75 Units (Char 1-3), Analog Input 2
 r/w ASCII codes 0-9, A-Z, space

3076-78 Units (Char 1-3), Analog Input 3
 r/w ASCII codes 0-9, A-Z, space

608 Units, Analog Input 1
 r/w 0 Temperature
 1 Units [3 characters]

618 Units, Analog Input 2
 r/w 0 Temperature
 1 Units [3 characters]

628 Units, Analog Input 3
 r/w 0 Temperature
 1 Units [3 characters]

Parameters Sorted by Modbus Register

0	Model, Diagnostic	506	Cycle Time, Control Output 1A
1	Serial Number, First Part, Diagnostic	507	Hysteresis 1A, PID Set 1
2	Serial Number, Second Part, Diagnostic	509	Cycle Time Type, Control Output 1A
3	Software Number, Diagnostic	510	Proportional Band 1A, PID Set 2
4	Revision, Diagnostic	511	Integral 1A, PID Set 2
5	Manufacturing Date, Diagnostic	512	Reset 1A, PID Set 2
8	Input 1, Diagnostic	513	Derivative 1A, PID Set 2
9	Input 2, Diagnostic	514	Rate 1A, PID Set 2
10	Input 3, Diagnostic	515	Dead Band 1A, PID Set 2
16	Output 1A, Diagnostic	517	Hysteresis 1A, PID Set 2
17	Output 1B, Diagnostic	520	Proportional Band 1A, PID Set 3
20	Retransmit 1, Diagnostic	521	Integral 1A, PID Set 3
21	Retransmit 2, Diagnostic	522	Reset 1A, PID Set 3
25	Save Changes to EE	523	Derivative 1A, PID Set 3
100	Input 1 Value, Status	524	Rate 1A, PID Set 3
101	Input 1 Error, Status	525	Dead Band 1A, PID Set 3
102	Alarm 1, Status	527	Hysteresis 1A, PID Set 3
103	% Power Output 1A, Status	530	Proportional Band 1A, PID Set 4
106	Alarm 2, Status	531	Integral 1A, PID Set 4
107	% Power Output 1B, Status	532	Reset 1A, PID Set 4
200	Auto/Manual Mode, Status	533	Derivative 1A, PID Set 4
201	Digital Input 1, Status	534	Rate 1A, PID Set 4
210	Input 1 Open Loop, Status	535	Dead Band 1A, PID Set 4
213	Digital Input 2, Status	537	Hysteresis 1A, PID Set 4
225	Digital Input 3, Status	540	Proportional Band 1A, PID Set 5
237	Digital Input 4, Status	541	Integral 1A, PID Set 5
298	Control Set Point	542	Reset 1A, PID Set 5
299	Set Differential Value	543	Derivative 1A, PID Set 5
300	Set Point 1, Value	544	Rate 1A, PID Set 5
301	Set Ratio Value	545	Dead Band 1A, PID Set 5
302	Alarm 1 Low Deviation, Alarm Set Points	547	Hysteresis 1A, PID Set 5
302	Alarm 1 Low Maximum Rate, Alarm Set Points	550	Proportional Band 1B, PID Set 1
302	Alarm 1 Low Set Point, Alarm Set Points	551	Integral 1B, PID Set 1
303	Alarm 1 High Deviation, Alarm Set Points	552	Reset 1B, PID Set 1
303	Alarm 1 High Maximum Rate, Alarm Set Points	553	Derivative 1B, PID Set 1
303	Alarm 1 High Set Point, Alarm Set Points	554	Rate 1B, PID Set 1
304	Autotune Set Point, System	555	Dead Band 1B, PID Set 1
305	Autotune PID, Autotune PID	556	Cycle Time Value, Control Output 1B
305	Cascade Inner Loop, Autotune PID	557	Hysteresis 1B, PID Set 1
307	Autotune PID Type, Autotune PID	559	Cycle Time Type, Control Output 1B
308	Digital Set Point 1, Control Set Points	560	Proportional Band 1B, PID Set 2
309	Boost Set Point (1B), Control Set Points	561	Integral 1B, PID Set 2
311	Clear Error Input 1, Key Press Simulation	562	Reset 1B, PID Set 2
312	Clear Alarm 1, Key Press Simulation	563	Derivative 1B, PID Set 2
313	Silence Alarm 1, Key Press Simulation	564	Rate 1B, PID Set 2
314	Digital Differential Set Point 1, Control Set Points	565	Dead Band 1B, PID Set 2
315	Digital Ratio Set Point 1, Control Set Points	567	Hysteresis 1B, PID Set 2
316	Remote/Local Set Point, Local/Remote Set Point	570	Proportional Band 1B, PID Set 3
321	Alarm 2 Low Deviation, Alarm Set Points	571	Integral 1B, PID Set 3
321	Alarm 2 Low Set Point, Alarm Set Points	572	Reset 1B, PID Set 3
321	Alarm 2 Maximum Low Rate, Alarm Set Points	573	Derivative 1B, PID Set 3
322	Alarm 2 High Deviation, Alarm Set Points	574	Rate 1B, PID Set 3
322	Alarm 2 High Set Point, Alarm Set Points	575	Dead Band 1B, PID Set 3
322	Alarm 2 Maximum High Rate, Alarm Set Points	577	Hysteresis 1B, PID Set 3
327	Digital Set Point 2, Control Set Points	580	Proportional Band 1B, PID Set 4
330	Clear Error Input 2, Key Press Simulation	581	Integral 1B, PID Set 4
331	Clear Alarm 2, Key Press Simulation	582	Reset 1B, PID Set 4
332	Silence Alarm 2, Key Press Simulation	583	Derivative 1B, PID Set 4
333	Digital Differential Set Point 2, Control Set Points	584	Rate 1B, PID Set 4
334	Digital Ratio Set Point 2, Control Set Points	585	Dead Band 1B, PID Set 4
343	Cascade Outer Loop, Autotune PID	587	Hysteresis 1B, PID Set 4
346	Digital Set Point 3	590	Proportional Band 1B, PID Set 5
349	Clear Error Input 3, Key Press Simulation	591	Integral 1B, PID Set 5
352	Digital Differential Set Point 3, Control Set Points	592	Reset 1B, PID Set 5
353	Digital Ratio Set Point 3, Control Set Points	593	Derivative 1B, PID Set 5
365	Digital Set Point 4, Control Set Points	594	Rate 1B, PID Set 5
371	Digital Differential Set Point 4, Control Set Points	595	Dead Band 1B, PID Set 5
372	Digital Ratio Set Point 4, Control Set Points	597	Hysteresis 1B, PID Set 5
452	Maximum Transfer Heat, System	600	Sensor, Analog Input 1
453	Maximum Transfer Cool, System	601	Sensor Type, Analog Input 1
454	Manual to Auto Transfer, System	602	Set Point Low Limit, Analog Input 1
500	Proportional Band 1A, PID Set 1	603	Set Point High Limit, Analog Input 1
501	Integral 1A, PID Set 1	604	Filter Time, Analog Input 1
502	Reset 1A, PID Set 1	605	Calibration Offset Value, Analog Input 1
503	Derivative 1A, PID Set 1	606	Decimal, Analog Input 1
504	Rate 1A, PID Set 1	607	Error Latch, Analog Input 1
505	Dead Band 1A, PID Set 1	608	Units, Analog Input 1
		610	Sensor, Analog Input 2
		611	Sensor Type, Analog Input 2

612	Set Point Low Limit, Analog Input 2	1100	Ramp to Set Point Mode, Operations
613	Set Point High Limit, Analog Input 2	1101	Ramp to Set Point Rate, Operations
614	Filter Time, Analog Input 2	1102	Ramp to Set Point Scale, Ramp to Set Point
615	Calibration Offset Value, Analog Input 2	1140	Control Type, Analog Input 2
616	Decimal, Analog Input 2	1141	Control Type, Analog Input 3
617	Error Latch, Analog Input 2	1300	Set Point, Set Lockout
618	Units, Analog Input 2	1302	Setup Page, Set Lockout
620	Sensor, Analog Input 3	1303	Factory Page, Set Lockout
621	Sensor Type, Analog Input 3	1306	Operations, Autotune PID, Set Lockout
622	Set Point Low Limit, Analog Input 3	1307	Operations, Edit PID, Set Lockout
623	Set Point High Limit, Analog Input 3	1308	Operations, Alarm Set Point, Set Lockout
624	Filter Time, Analog Input 3	1315	Clear Locks, Set Lockout
625	Calibration Offset Value, Analog Input 3	1316	Operations, PID Crossover, Set Lockout
626	Decimal, Analog Input 3	1317	Operations, Ramp Set Point, Set Lockout
627	Error Latch, Analog Input 3	1318	Operations, Control Set Point, Set Lockout
628	Units, Analog Input 3	1319	Remote/Local Set Point Operation, Set Lockout
680	Scale Low, Analog Input 1	1330-33	Set/Change Password, Set Lockout
681	Scale High, Analog Input 1	1400-15	Custom Main Page Parameters (P1 to P16)
682	Scale Low, Analog Input 2	1500	CJC1 Temp, Diagnostic
683	Scale High, Analog Input 2	1501	CJC1 AtoD, Diagnostic
684	Scale Low, Analog Input 3	1504	Input 1 AtoD, Diagnostic
685	Scale High, Analog Input 3	1505	Input 2 AtoD, Diagnostic
693	Scaling, Analog Input 1	1506	Input 3 AtoD, Diagnostic
694	Scaling, Analog Input 2	1513	Display Test, Test
695	Scaling, Analog Input 3	1514	Test Outputs, Test
700	Function, Control Output 1A	1515	Line Frequency, Diagnostic
701	Process, Control Output 1A	1531	CJC2-CJC3 Temp, Diagnostic
702	Alarm Type, Alarm Output 1	1532	CJC2-CJC3 AtoD, Diagnostic
703	Alarm Hysteresis, Alarm Output 1	1601	Restore Calibration, Inputs 1-3
704	Latching, Alarm Output 1	1602	Full Defaults, Test
705	Silencing, Alarm Output 1	1603	Calibrate Input 1, Calibration
706	Alarm Sides, Alarm Output 1	1604	Calibrate Process Output 1A, 4.000mA
707	Alarm Logic, Alarm Output 1	1605	Calibrate Process Output 1A, 20.000mA
708	Alarm Messages, Alarm Output 1	1606	Calibrate Process Output 1A, 1.000V
709	Retransmit Source, Retransmit Output 1	1607	Calibrate Process Output 1A, 10.000V
710	Low Scale, Retransmit Output 1	1608	Calibrate Calibrate Input 2, Calibration
711	High Scale, Retransmit Output 1	1609	Calibrate Process Output 1B, 4.000mA
712	Scale Offset, Retransmit Output 1	1610	Calibrate Process Output 1B, 20.000mA
714	High Power Limit, Control Output 1A	1611	Calibrate Process Output 1B, 1.000V
715	Low Power Limit, Control Output 1A	1612	Calibrate Process Output 1B, 10.000V
716	Alarm Source, Alarm Output 1	1613	Calibrate Input 3, Calibration
717	Function, Control Output 1B	1624	Calibrate Retransmit Output 1, 4.000mA
718	Process, Control Output 1B	1625	Calibrate Retransmit Output 1, 20.000mA
719	Alarm Type, Alarm Output 2	1626	Calibrate Retransmit Output 1, 1.000V
720	Alarm Hysteresis, Alarm Output 2	1627	Calibrate Retransmit Output 1, 10.000V
721	Latching, Alarm Output 2	1629	Calibrate Retransmit Output 2, 4.000mA
722	Silencing, Alarm Output 2	1630	Calibrate Retransmit Output 2, 20.000mA
723	Alarm Sides, Alarm Output 2	1631	Calibrate Retransmit Output 2, 1.000V
724	Alarm Logic, Alarm Output 2	1632	Calibrate Retransmit Output 2, 10.000V
725	Alarm Messages, Alarm Output 2	1910	Process Display
726	Retransmit Source, Retransmit Output 2	1911	Process Display Time, Input 1
727	Low Scale, Retransmit Output 2	1912	Process Display Time, Input 2
728	High Scale, Retransmit Output 2	1913	Process Display Time, Input 3
729	Scale Offset, Retransmit Output 2	1914	LED Intensity, Process Display
731	High Power Limit, Control Output 1B	1915	Auto/Manual Slidewire Calibration, Analog Input 3
732	Low Power Limit, Control Output 1B	1916	Slidewire Deadband, Analog Input 3
733	Alarm Source, Alarm Output 2	1917	Slidewire Hysteresis, Analog Input 3
836	Analog Range, Retransmit Output 1	1918	Slidewire Learn Closed, Analog Input 3
837	Analog Range, Retransmit Output 2	1919	Slidewire Learn Open, Analog Input 3
844	Duplex Output, Control Output 1A	1922	Cascade Internal Set Point
880	Failure Mode, System	1923	Show °F or °C, System
881	Boost Power Mode, Control Output 1B	1925	Cascade, Analog Input 3
882	Boost Set Point Type, Control Output 1B	1926	Cascade Low Deviation, Analog Input 3
883	Boost Power, Control Set Point	1926	Cascade Low Range, Analog Input 3
884	Boost Delay Time, Control Set Point	1927	Cascade High Deviation, Analog Input 3
885	Boost Type, Control Output 1B	1927	Cascade High Range, Analog Input 3
900	PID Units, System	1951	PID Crossover, Operations
901	°F or °C, System	1961	PID Cross 1-2, Operations
903	Input 1 Failure, System	1962	PID Cross 2-3, Operations
904	Open Loop Detect, System	1963	PID Cross 3-4, Operations
1060	Function, Digital Input 1	1964	PID Cross 4-5, Operations
1061	Condition, Digital Input 1	2600	Proportional Band 1A, Cascade PID Set 1
1062	Function, Digital Input 2	2601	Integral 1A, Cascade PID Set 1
1063	Condition, Digital Input 2	2602	Reset 1A, Cascade PID Set 1
1064	Function, Digital Input 3	2603	Derivative 1A, Cascade PID Set 1
1065	Condition, Digital Input 3	2604	Rate 1A, Cascade PID Set 1
1066	Function, Digital Input 4	2605	Dead Band 1A, Cascade PID Set 1
1067	Condition, Digital Input 4	2607	Hysteresis 1A, Cascade PID Set 1

2610	Proportional Band 1B, Cascade PID Set 1	3076-3078	Units (Char 1-3), Analog Input 3
2611	Integral 1B, Cascade PID Set 1	3200-3209	Name (Char 01-10), Alarm Output 1
2612	Reset 1B, Cascade PID Set 1	3210-3219	Name (Char 01-10), Alarm Output 2
2613	Derivative 1B, Cascade PID Set 1	4501-4517	Message 1 (Line 01, Char 01-17), Static Message
2614	Rate 1B, Cascade PID Set 1	4521-4537	Message 1 (Line 02, Char 01-17), Static Message
2615	Dead Band 1B, Cascade PID Set 1	4541-4557	Message 1 (Line 03, Char 01-17), Static Message
2617	Hysteresis 1B, Cascade PID Set 1	4561-4577	Message 1 (Line 04, Char 01-17), Static Message
2620	Proportional Band 1A, Cascade PID Set 2	4581-4597	Message 2 (Line 01, Char 01-17), Static Message
2621	Integral 1A, Cascade PID Set 2	4601-4617	Message 2 (Line 02, Char 01-17), Static Message
2622	Reset 1A, Cascade PID Set 2	4621-4637	Message 2 (Line 03, Char 01-17), Static Message
2623	Derivative 1A, Cascade PID Set 2	4641-4657	Message 2 (Line 04, Char 01-17), Static Message
2624	Rate 1A, Cascade PID Set 2	4661-4677	Message 3 (Line 01, Char 01-17), Static Message
2625	Dead Band 1A, Cascade PID Set 2	4681-4697	Message 3 (Line 02, Char 01-17), Static Message
2627	Hysteresis 1A, Cascade PID Set 2	4701-4717	Message 3 (Line 03, Char 01-17), Static Message
2630	Proportional Band 1B, Cascade PID Set 2	4721-4737	Message 3 (Line 04, Char 01-17), Static Message
2631	Integral 1B, Cascade PID Set 2	4741-4757	Message 4 (Line 01, Char 01-17), Static Message
2632	Reset 1B, Cascade PID Set 2	4761-4777	Message 4 (Line 02, Char 01-17), Static Message
2633	Derivative 1B, Cascade PID Set 2	4781-4797	Message 4 (Line 03, Char 01-17), Static Message
2634	Rate 1B, Cascade PID Set 2	4801-4817	Message 4 (Line 04, Char 01-17), Static Message
2635	Dead Band 1B, Cascade PID Set 2	5506-5515	Offset Point 01-10, Analog Input 1
2637	Hysteresis 1B, Cascade PID Set 2	5516-5525	Offset Point 01-10, Analog Input 2
2640	Proportional Band 1A, Cascade PID Set 3	5526-5535	Offset Point 01-10, Analog Input 3
2641	Integral 1A, Cascade PID Set 3	5536-5545	Offset Value 01-10, Analog Input 1
2642	Reset 1A, Cascade PID Set 3	5546-5555	Offset Value 01-10, Analog Input 2
2643	Derivative 1A, Cascade PID Set 3	5556-5565	Offset Value 01-10, Analog Input 3
2644	Rate 1A, Cascade PID Set 3	5566	Clear Input 1 Offsets, Analog Input 1
2645	Dead Band 1A, Cascade PID Set 3	5567	Clear Input 2 Offsets, Analog Input 2
2647	Hysteresis 1A, Cascade PID Set 3	5568	Clear Input 3 Offsets, Analog Input 3
2650	Proportional Band 1B, Cascade PID Set 3	5569	Square Root, Analog Input 1
2651	Integral 1B, Cascade PID Set 3	5570	Square Root, Analog Input 2
2652	Reset 1B, Cascade PID Set 3	5571	Square Root, Analog Input 3
2653	Derivative 1B, Cascade PID Set 3	5572	Offset Type, Analog Input 1
2654	Rate 1B, Cascade PID Set 3	5573	Offset Type, Analog Input 2
2655	Dead Band 1B, Cascade PID Set 3	5574	Offset Type, Analog Input 3
2657	Hysteresis 1B, Cascade PID Set 3		
2660	Proportional Band 1A, Cascade PID Set 4		
2661	Integral 1A, Cascade PID Set 4		
2662	Reset 1A, Cascade PID Set 4		
2663	Derivative 1A, Cascade PID Set 4		
2664	Rate 1A, Cascade PID Set 4		
2665	Dead Band 1A, Cascade PID Set 4		
2667	Hysteresis 1A, Cascade PID Set 4		
2670	Proportional Band 1B, Cascade PID Set 4		
2671	Integral 1B, Cascade PID Set 4		
2672	Reset 1B, Cascade PID Set 4		
2673	Derivative 1B, Cascade PID Set 4		
2674	Rate 1B, Cascade PID Set 4		
2675	Dead Band 1B, Cascade PID Set 4		
2677	Hysteresis 1B, Cascade PID Set 4		
2680	Proportional Band 1A, Cascade PID Set 5		
2681	Integral 1A, Cascade PID Set 5		
2682	Reset 1A, Cascade PID Set 5		
2683	Derivative 1A, Cascade PID Set 5		
2684	Rate 1A, Cascade PID Set 5		
2685	Dead Band 1A, Cascade PID Set 5		
2687	Hysteresis 1A, Cascade PID Set 5		
2690	Proportional Band 1B, Cascade PID Set 5		
2691	Integral 1B, Cascade PID Set 5		
2692	Reset 1B, Cascade PID Set 5		
2693	Derivative 1B, Cascade PID Set 5		
2694	Rate 1B, Cascade PID Set 5		
2695	Dead Band 1B, Cascade PID Set 5		
2697	Hysteresis 1B, Cascade PID Set 5		
3000-3006	Name (Char 01-07), Digital Input 1		
3010-3016	Name (Char 01-07), Digital Input 2		
3020-3026	Name (Char 01-07), Digital Input 3		
3030-3036	Name (Char 01-07), Digital Input 4		
3050	Activate Message, Digital Input 1		
3051	Activate Message, Digital Input 2		
3052	Activate Message, Digital Input 3		
3053	Activate Message, Digital Input 4		
3060	Message Display Time, Digital Input 1		
3061	Message Display Time, Digital Input 2		
3062	Message Display Time, Digital Input 3		
3063	Message Display Time, Digital Input 4		
3070-3072	Units (Char 1-3), Analog Input 1		
3073-3075	Units (Char 1-3), Analog Input 2		

Notes:

A

Appendix

Specifications	A.2
Ordering Information	A.3
Declaration of Conformity	A.4
Glossary	A.5
Index	A.8
Software Map	A.13
About Watlow and Warranty Information	
.....	Inside Back Cover

Specifications

(2329)

Universal Analog Inputs 1 (2 and 3 optional)

- Update rates, IN1 = 20Hz, IN2 and IN3 = 10Hz

Thermocouple

- Type J, K, T, N, C (W5), E, PTII, D (W3), B, R, S

RTD

- 2- or 3-wire platinum, 100, 500 or 1000
- JIS or DIN curves, 1.0 or 0.1 indication

Process

- Input resolution 50,000 bits at full scale
- Range selectable: 0-10V \equiv (dc), 0-5V \equiv (dc), 1-5V \equiv (dc), 0-50mV, 0-20mA, 4-20mA
- Voltage input impedance 20K
- Current input impedance 100

Digital Inputs (4)

- Update rate = 10Hz
- Contact or dc voltage
- 10K input impedance

Control Outputs (1A, 1B)

- Update rate = 20Hz

Open Collector/Switched dc

- Internal load switching (nominal):
Switched dc, 22 to 28V \equiv (dc), limited @ 30mA
- External load switching max.:
Open collector 42V \equiv (dc) @ 0.5A

Solid-state Relay

- Zero switched, optically coupled, 0.5A @ 24V~(ac) minimum, 253V~(ac) maxi.

Electromechanical Relay

- Form C, 2A @ 250V~(ac) or 30V \equiv (dc) max.
- Resistive or inductive load
- Without contact suppression

Process Outputs (Optional Retransmit)

- Update rate = 1Hz
- User-selectable 0-10V \equiv (dc), 0-5V \equiv (dc), 1-5V \equiv (dc) @ 1K min., 0-20mA, 4-20mA @ 800 max.
- Resolution:
dc ranges = 2.5mV nominal
mA ranges = 5 μ A nominal
- Calibration accuracy:
dc ranges = \pm 15mV
mA ranges = \pm 30 μ A
- Temperature stability 100ppm/ $^{\circ}$ C

Alarm Outputs

- Output update rate 1Hz
- Electromechanical relay, Form C, 2A @ 30V \equiv (dc) or 240V~(ac) maximum

Communications

- EIA-232 and EIA-485 serial communications with Modbus™ RTU protocol

Safety and Agency Approvals

- UL®/C-UL 916-listed, File # E185611

Process Control Equipment

- CE
 - EN 61010-1
 - EN 61326
 - EN 55011
- NEMA 4X and IP65

Terminals

- Touch-safe, removable terminal blocks, accepts 12 to 22-gauge wire

Dimensions

- Width x height x depth
3.93 in x 3.93 in x 3.85 in panel mount
(99 mm x 99 mm x 97 mm)

Power

- 100-240V~(ac), -15%, +10%; 50/60Hz, \pm 5%
- 39VA maximum power consumption
- Data retention upon power failure via nonvolatile memory.

Sensor input isolation from input to input to output to communication circuitry is 500V~ (ac).

Operating Environment

- 32 to 149°F (0 to 65°C)
- 0 to 90% RH, non-condensing
- Storage temperature: -40 to 158°F (-40 to 70°C)

Accuracy

- Calibration accuracy and sensor conformity: \pm 0.1% of span \pm 1°C @ 77°F \pm 5°F (25°C \pm 3°C) ambient, and rated line voltage \pm 10% with the following exceptions:
Type T, 0.12% of span for -200°C to -50°C
Types R and S, 0.15% of span for 0°C to 100°C
Type B, 0.24% of span for 870°C to 1700°C
- Accuracy span: Less than or equal to operating ranges, 1000°F/540°C minimum
- Temperature stability: \pm 0.1°F/ $^{\circ}$ F (\pm 0.1°C/ $^{\circ}$ C) rise in ambient for thermocouples
- \pm 0.05°F/ $^{\circ}$ F (\pm 0.05°C/ $^{\circ}$ C) rise in ambient for RTD sensors

Displays

- Process: 5, seven-segment LED red
- Control interface display: high-definition LCD green

Sensor Operating Ranges

Type J:	32	to	1500°F	or	0	to	815°C
Type K:	-328	to	2500°F	or	-200	to	1370°C
Type T:	-328	to	750°F	or	-200	to	400°C
Type N:	32	to	2372°F	or	0	to	1300°C
Type E:	-328	to	1470°F	or	-200	to	800°C
Type C:	32	to	4200°F	or	0	to	2315°C
Type D:	32	to	4352°F	or	0	to	2400°C
Type PTII:	32	to	2543°F	or	0	to	1395°C
Type R:	32	to	3200°F	or	0	to	1760°C
Type S:	32	to	3200°F	or	0	to	1760°C
Type B:	32	to	3300°F	or	0	to	1816°C
RTD (DIN):	-328	to	1472°F	or	-200	to	800°C
RTD (JIS):	-328	to	1166°F	or	-200	to	800°C
Process:	-19999	to	30000	units			

Sensor Accuracy Ranges:

Input ranges

Type J:	32	to	1382°F	or	0	to	750°C
Type K:	-328	to	2282°F	or	-200	to	1250°C
Type T:	-328	to	662°F	or	-200	to	350°C
Type N:	32	to	2282°F	or	0	to	1250°C
Type E:	-328	to	1470°F	or	-200	to	800°C
Type C(W5)	32	to	4200°F	or	0	to	2315°C
Type D(W3)	32	to	4352°F	or	0	to	2400°C
Type PTII:	32	to	2540°F	or	0	to	1393°C
Type R:	32	to	2642°F	or	0	to	1450°C
Type S:	32	to	2642°F	or	0	to	1450°C
Type B:	1598	to	3092°F	or	870	to	1700°C
RTD (DIN):	-328	to	1472°F	or	-200	to	800°C
RTD (JIS):	-328	to	1166°F	or	-200	to	630°C
Process:	-19999	to	30000	units			

UL® is a registered trademark of Underwriter's Laboratories, Inc.

NOTE: Specifications subject to change without notice.

Ordering Information (2330)

1/4 DIN Single-Channel Controller

Series F4P

F4 P - A -

Single-Channel temperature/process controller, 1 universal analog input, 2 alarms, EIA-232/485 communications, 4 events/digital inputs

Power Supply

H = 100-240V \approx (ac/dc)

Output 1A

C = Open collector/switched dc

E = Electromechanical relay, Form C, 2A without contact suppression

K = Solid-state Form A 0.5A relay without contact suppression

F = Process, 0-5, 1-5, 0-10V \approx (dc), 0-20mA, 4-20mA

Output 1B

A = None

C = Open collector/switched dc

E = Electromechanical relay, Form C, 2A without contact suppression

K = Solid-state Form A 0.5A relay without contact suppression

F = Process, 0-5, 1-5, 0-10V \approx (dc) 0-20mA, 4-20mA

Control Operation

A = Standard Control Operation

B = Enhanced Control Operation, dual universal inputs, cascade, ratio, differential, slidewire control

Auxiliary Retransmit Module

0 = None

1 = Single retransmit output 0-5, 1-5, 0-10V \approx (dc), 0-20mA, 4-20mA

2 = Dual retransmit outputs 0-5, 1-5, 0-10V \approx (dc), 0-20mA, 4-20mA

Language Option

1 = English - 100 RTD

2 = German - 100 RTD

3 = French - 100 RTD

4 = Spanish - 100 RTD

5 = English - 500 & 1000 RTD

6 = German - 500 & 1000 RTD

7 = French - 500 & 1000 RTD

8 = Spanish - 500 & 1000 RTD

Display and Custom Options

RG = Standard Red Upper LED/Green Lower LCD only

XX = Custom options: software, setting parameters, overlays

Declaration of Conformity



Series F4

Watlow
1241 Bundy Blvd.
Winona, MN 55987 USA

an ISO 9001 approved facility since 1996.

Declares that the following product:

Designation: Series F4
Model Numbers: F4 (S, D or P) (H or L) – (C, E, F or K) (A, C, E, F or K) (A, C, F or K) (A, C, F, K, 0 or 6) – (0, 1 or 2) (Any three numbers of letters)
Classification: Temperature control, Installation Category II, Pollution degree 2 continuous unmonitored operation, IP65 Front panel
Rated Voltage: 100 to 240 V~ (ac) or 24 to 28 V (ac or dc), 50/60 Hz
Rated Power: 39 VA maximum

Meets the essential requirements of the following European Union Directives by using the relevant standards show below to indicate compliance.

2004/108/EC Electromagnetic Compatibility Directive

EN 61326-1	2005		Electrical equipment for measurement, control and laboratory use – EMC requirements (Industrial Immunity, Class A* Emissions).
EN 61000-4-2	1996	+ A1,A2	Electrostatic Discharge Immunity
EN 61000-4-3	2006		Radiated Field Immunity
EN 61000-4-4	2004		Electrical Fast-Transient / Burst Immunity
EN 61000-4-5	2006		Surge Immunity
EN 61000-4-6	1996	+ A1,A2,A3	Conducted Immunity
EN 61000-4-11	2004		Voltage Dips, Short Interruptions and Voltage Variations Immunity
EN 61000-3-2	2006		Harmonic Current Emissions
EN 61000-3-3	2005		Voltage Fluctuations and Flicker
SEMI F47	2000		Specification for Semiconductor Sag Immunity Figure R1-1

*NOTE: Not appropriate for use in commercial or residential applications without additional filtering.

2006/95/EC Low-Voltage Directive

EN 61010-1	2001		Safety Requirements of electrical equipment for measurement, control and laboratory use. Part 1: General requirements
-------------------	-------------	--	--

Per 2002/96/EC WEEE Directive  Please Recycle Properly

**These devices contain lead solder and are not RoHS compliant.
They are a Control Devices and fall outside the scope of 2002/95/EC Directive.**

Raymond D. Feller III
Name of Authorized Representative

Winona, Minnesota, USA
Place of Issue

General Manager
Title of Authorized Representative

February 2009
Date of Issue

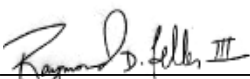
Signature of Authorized Representative

Glossary

ac (~) — See alternating current.

ac/dc (≈) — Both direct and alternating current.

alternating current — An electric current that reverses at regular intervals, and alternates positive and negative values.

American Wire Gauge (AWG) — A standard of the dimensional characteristics of wire used to conduct electrical current or signals. AWG is identical to the Brown and Sharpe (B & S) wire gauge.

auto-tune — A feature that automatically sets temperature control PID values to match a particular thermal system.

AWG — See American Wire Gauge.

baud rate — The rate of information transfer in serial communications, measured in bits per second.

burst fire — A power control method that repeatedly turns on and off full ac cycles. Also called zero-cross fire, it switches close to the zero-voltage point of the ac sine wave. Variable-time-base burst fire selectively holds or transits ac cycles to achieve the desired power level. See zero cross.

calibration accuracy — Closeness between the value indicated by a measuring instrument and a physical constant or known standard.

calibration offset — An adjustment to eliminate the difference between the indicated value and the actual process value.

cascade — Control algorithm in which the output of one control loop provides the set point for another loop. The second loop, in turn, determines the control action.

CE — A manufacturer's mark that demonstrates compliance with European Union (EU) laws governing products sold in Europe.

chatter — The rapid on-off cycling of an electromechanical relay or mercury displacement relay due to insufficient controller bandwidth. It is commonly caused by excessive gain, little hysteresis and short cycle time.

CJC — See cold junction compensation.

closed loop — A control system that uses a sensor to measure a process variable and makes decisions based on that feedback.

cold junction — See junction, cold.

cold junction compensation — Electronic means to compensate for the effective temperature at the cold junction.

control mode — The type of action that a controller uses. For example, on/off, time proportion-

ing, PID, automatic or manual, and combinations of these.

cycle time — The time required for a controller to complete one on-off-on cycle. It is usually expressed in seconds.

dead band — The range through which a variation of the input produces no noticeable change in the output. In the deadband, specific conditions can be placed on control output actions. Operators select the dead band. It is usually above the heating proportional band and below the cooling proportional band.

default parameters — The programmed instructions that are permanently stored in the microprocessor software.

derivative — The rate of change in a process variable. Also known as rate. See PID.

derivative control (D) — The last term in the PID control algorithm. Action that anticipates the rate of change of the process, and compensates to minimize overshoot and undershoot. Derivative control is an instantaneous change of the control output in the same direction as the proportional error. This is caused by a change in the process variable (PV) that decreases over the time of the derivative (TD). The TD is in units of seconds.

Deutsche Industrial Norm (DIN) — A set of technical, scientific and dimensional standards developed in Germany. Many DIN standards have worldwide recognition.

DIN — See Deutsche Industrial Norm.

droop — In proportional controllers, the difference between set point and actual value after the system stabilizes.

duty cycle — The percentage of a cycle time in which the output is on.

EIA — See Electronics Industries of America.

EIA/TIA -232, -422, -423 and -485 — Data communications standards set by the Electronic Industries of America and Telecommunications Industry Association. Formerly referred to as RS- (Recognized Standard).

Electronics Industries of America (EIA) — An association in the US that establishes standards for electronics and data communications.

external transmitter power supply — A dc voltage source that powers external devices.

filter, digital — A filter that slows the response of a system when inputs change unrealistically or too fast. Equivalent to a standard resistor-capacitor (RC) filter.

form A — A single-pole, single-throw relay that uses only the normally open (NO) and common con-

tacts. These contacts close when the relay coil is energized. They open when power is removed from the coil.

form B — A single-pole, single-throw relay that uses only the normally closed (NC) and common contacts. These contacts open when the relay coil is energized. They close when power is removed from the coil.

form C — A single-pole, double-throw relay that uses the normally open (NO), normally closed (NC) and common contacts. The operator can choose to wire for a form A or form B contact.

Hertz (Hz) — Frequency, measured in cycles per second.

hysteresis — A change in the process variable required to re-energize the control or alarm output. Sometimes called switching differential.

integral — Control action that automatically eliminates offset, or droop, between set point and actual process temperature.

integral control (I) — A form of temperature control. The I of PID. See integral.

inverse scaling — The relationship between the low and high scale value and the process input or output. Minimum process signal is represented by scale high value and maximum process signal is represented by scale low value.

isolation — Electrical separation of sensor from high voltage circuitry. Allows use of grounded or ungrounded sensing element.

JIS — See Joint Industrial Standards.

Joint Industrial Standards (JIS) — A Japanese agency that establishes and maintains standards for equipment and components. Also known as JISC (Japanese Industrial Standards Committee), its function is similar to Germany's Deutsche Industrial Norm (DIN).

junction, cold — Connection point between thermocouple metals and the electronic instrument. See junction, reference.

junction, reference — The junction in a thermocouple circuit held at a stable, known temperature (cold junction). Standard reference temperature is 32°F (0°C).

LCD — See liquid crystal display.

LED — See light emitting diode.

light emitting diode (LED) — A solid state electronic device that glows when electric current passes through it.

liquid crystal display (LCD) — A type of digital display made of a material that changes reflectance or transmittance when an electrical field is applied to it.

limit or limit controller — A highly reliable, discrete safety device (redundant to the primary controller) that monitors and limits the temperature of the process, or a point in the process. When temperature exceeds or falls below the limit set point, the limit controller interrupts power through the load circuit. A limit controller can protect equipment and people when it is correctly installed with its own power supply, power lines, switch and sensor.

manual mode — A selectable mode that has no automatic control aspects. The operator sets output levels.

Modbus™ — A digital communications protocol owned by AEG Schneider Automation for industrial computer networks.

Modbus™ RTU — Remote Terminal Unit, an individual Modbus™-capable device on a network.

NEMA 4X — A NEMA (National Electrical Manufacturer's Association) specification for determining resistance to moisture infiltration. This rating certifies the controller as washable and corrosion resistant.

normal scaling — The relationship between the low and high scale value and the process input or output. Minimum process signal is represented by scale low value and maximum process signal is represented by scale high value.

on/off controller — A temperature controller that operates in either full on or full off modes.

open loop — A control system with no sensory feedback.

output — Control signal action in response to the difference between set point and process variable.

overshoot — The amount by which a process variable exceeds the set point before it stabilizes.

page — A fixed length block of data that can be stored as a complete unit in the computer memory.

P control — Proportioning control.

PD control — Proportioning control with derivative (rate) action.

PDR control — Proportional derivative control with manual reset, used in fast responding systems where the reset causes instabilities. With PDR control, an operator can enter a manual reset value that eliminates droop in the system.

PI control — Proportioning control with integral (auto-reset) action.

PID — Proportional, integral, derivative. A control mode with three functions: proportional action dampens the system response, integral corrects for droop, and derivative prevents overshoot and undershoot.

process variable — The parameter that is controlled or measured. Typical examples are temperature, relative humidity, pressure, flow, fluid level, events, etc. The high process variable is the highest value of the process range, expressed in engineering units. The low process variable is the lowest value of the process range.

proportional — Output effort proportional to the error from set point. For example, if the proportional band is 20° and the process is 10° below set point, the heat proportioned effort is 50 percent. The lower the PB value, the higher the gain.

proportional band (PB) — A range in which the proportioning function of the control is active. Expressed in units, degrees or percent of span. See PID.

proportional control — A control using only the P (proportional) value of PID control.

radio frequency interference (RFI) — Electromagnetic waves between the frequencies of 10 KHz and 300 GHz that can affect susceptible systems by conduction through sensor or power input lines, and by radiation through space.

ramp — A programmed increase in the temperature of a set point system.

range — The area between two limits in which a quantity or value is measured. It is usually described in terms of lower and upper limits.

rate — Anticipatory action that is based on the rate of temperature change, and compensates to minimize overshoot and undershoot. See derivative.

rate band — A range in which the rate function of a controller is active. Expressed in multiples of the proportional band. See PID.

reference junction — see junction, reference.

reset — Control action that automatically eliminates offset, or droop, between set point and actual process temperature. Also see integral.

automatic reset — The integral function of a PI or PID temperature controller that adjusts the process temperature to the set point after the system stabilizes. The inverse of integral.

automatic power reset — A feature in latching limit controls that does not recognize power outage as a limit condition. When power is restored, the output is re-energized automatically, as long as the temperature is within limits.

resistance temperature detector (RTD) — A sensor that uses the resistance temperature characteristic to measure temperature. There are two basic types of RTDs: the wire RTD, which is usually made of platinum, and the thermistor, which is

made of a semiconductor material. The wire RTD is a positive temperature coefficient sensor only, while the thermistor can have either a negative or positive temperature coefficient.

retransmit — An output that provides a scalable analog signal that represents an input value, set point value or output power level.

RFI — See radio frequency interference.

RTD — See resistance temperature detector.

serial communications — A method of transmitting information between devices by sending all bits serially over a single communication channel.

set point — The desired value programmed into a controller. For example, the temperature at which a system is to be maintained.

SI (Systeme Internationale) — The system of standard metric units.

switching differential — See hysteresis.

thermal system — A regulated environment that consists of a heat source, heat transfer medium or load, sensing device and a control instrument.

thermocouple (t/c) — A temperature sensing device made by joining two dissimilar metals. This junction produces an electrical voltage in proportion to the difference in temperature between the hot junction (sensing junction) and the lead wire connection to the instrument (cold junction).

thermocouple break protection — The ability of a control to detect a break in the thermocouple circuit and take a predetermined action.

time proportioning control — A method of controlling power by varying the on/off duty cycle of an output. This variance is proportional to the difference between the set point and the actual process temperature.

transmitter — A device that transmits temperature data from either a thermocouple or a resistance temperature detector (RTD) by way of a two-wire loop. The loop has an external power supply. The transmitter acts as a variable resistor with respect to its input signal. Transmitters are desirable when long lead or extension wires produce unacceptable signal degradation.

WATLINK — A Windows-based software application for configuring and communicating with Watlow controllers.

zero cross — Action that provides output switching only at or near the zero-voltage crossing points of the ac sine wave. See burst fire.

zero switching — See zero cross.

Index

Boldface page numbers refer to parameter entries.

Ⓢ key 2.2
0.000V, Calibrate, Input x (1 to 3) **6.29**
0.00mV Thermocouple, Calibrate Input x (1 to 3) **6.29**
1.000V, Calibrate Output x (1A or 1B) **6.30**
1.000V, Retransmit x (1 and 2) **6.30**
4.000mA, Calibrate Input x (1 to 3) **6.30**
4.000mA, Calibrate Output x (1A or 1B) **6.30**
4.000mA, Calibrate Retransmit x (1 and 2) **6.30**
10.000V, Calibrate Input x (1 to 3) **6.30**
10.000V, Calibrate Output x (1A or 1B) **6.31**
10.000V, Calibrate Retransmit x (1 and 2) **6.31**
15.0 Ohms, Calibrate Input x (1 to 3 RTD) **6.29**
15.0 Ohms, Calibrate Input 3 slidewire **6.30**
20.000mA, Calibrate Input x (1 to 3) **6.30**
20.000mA, Calibrate Output x (1A or 1B) **6.30**
20.000mA, Calibrate Retransmit x (1 and 2) **6.30**
32°F Type J, Calibrate Input x (1 to 3) **6.29**
50.00mV Thermocouple, Calibrate Input x (1 to 3) **6.29**
380.0 Ohms, Calibrate Input x (1 to 3) **6.29**
1000 Ohms, Calibrate Input 3 slidewire **6.29**
°F or °C **6.11**

A

A to D, CJC x (1 to 3) **6.28**
A to D, Input x (1 to 3) **6.28**
accuracy A.2
Activate Message **6.17**
active output indicator lights 2.2
Address **6.20**
agency approvals A.2

alarms
clearing 3.1
deviation 3.1, 7.10
features 7.10 - 7.11
operation 3.1
process 3.1, 7.10
rate 3.1, 7.10
self-clearing 7.11
set points 7.10
troubleshooting 2.5
Alarm x (1 or 2) Condition **6.2**
Alarm x (1 or 2) High Deviation **6.7**
Alarm x (1 or 2) High Set Point 7.10 - 7.11, **6.6**
Alarm x (1 or 2) Low Deviation **6.7**
Alarm x (1 or 2) Low Set Point 7.10 - 7.11, **6.6**
Alarm x (1 or 2) Maximum High Rate **6.7**
Alarm x (1 or 2) Maximum Low Rate **6.7**
Alarm Hysteresis **6.19**, 7.10
alarm latching 7.11 — See also Latching
Alarm Logic **6.19**
Alarm Messages **6.19**
Alarm Name **6.19** — see also Name
alarm output indicator lights 2.2
Alarm Output x (1 and 2) Menu 6.19
Alarm Set Points 3.1, **6.6**, 7.10
Alarm Set Points Menu 6.6 - 6.7
Alarm Sides **6.19**, 7.11
alarm silencing 7.11 — see also Silencing
Alarm Source **6.19**
alarm status, indicator light 2.2
Alarm Type **6.19**
Alternate Control 6.17, 7.15
ambient temperature 3.3
Analog Input 2 Menu 6.13
Analog Input 3 Menu 6.15 - 6.16
Analog Input x (1 to 3) Menu 6.12 - 6.15
wiring 8.6 - 8.8
Analog Range **6.20**
Auto/Manual Key 2.2
Auto/Manual Light 2.2
Auto/Manual Slidewire Calibration **6.15**
automatic and manual operation 2.3

Autotune PID 3.1 - 3.2, **6.4**, 7.9
Autotune PID Menu 6.4
Autotune PID Type **6.4**
Autotune Set Point **6.11**
autotuning 3.1 - 3.2, 7.9
lockout 6.26
multiple PID sets 3.3
PID 3.1 - 3.2
set point value 3.2, 7.9
Autotuning Channel x (1 or 2) **6.2**

B

Baud Rate **6.20**
B&B Converter 8.13
boost cool 7.12
Boost Delay Time **6.8**
boost heat 7.12
boost on delay 7.12
Boost Power **6.8**, 7.12
Boost Power Mode **6.18**
Boost Set Point **6.8**
Boost Set Point Type **6.19**
Boost Type **6.18**
burst fire 7.8
heater life 7.8
noise generation (RFI) 7.8
sine wave 7.8

C

Calibrate Input x (1 to 3) Menu 6.27 - 6.28
Calibrate Output x (1A or 1B) and Retransmit x (1 and 2) Menu 6.28 - 6.29
Calibration Offset Value **6.14**
calibration offset — see multiple input offsets
Calibration Retransmit x (1 or 2) Menu 6.30 - 6.31
calibration, overview 5.3
inputs 5.3 - 5.4
outputs 5.5 - 5.6
Cascade **6.16**
Cascade High Deviation **6.16**
Cascade High Range **6.16**
Cascade Inner Loop **6.4**
Cascade Low Deviation **6.16**
Cascade Low Range **6.16**
Cascade Outer Loop **6.4**

CE Declaration of Conformity A.4
 Change Password 5.2, **6.26**
 changing and setting password 6.26
 charts
 Operations Page Record 6.10
 Custom Main Page Record 6.25
 Setup Record 6.23 – 6.24
 chattering 7.6
 CJCx (1 to 3) A to D, Diagnostic **6.28**
 CJCx (1 to 3) Temp, Diagnostic **6.28**
 Clear Input x (1 to 3) Offsets **6.14**
 Clear Locks **6.26**
 clearing alarms 3.1
 clearing errors 3.1
 closed loop 7.5
 closed-loop configuration 2.3, 7.5
 CMC converter 8.13
 Communications **6.20**, 9.1.-9.13
 communications indicator light 2.2
 Communications Menu 6.20
 communications wiring 8.12 – 8.13
 B&B converter 8.13
 CMC converter 8.13
 EIA-232 to EIA-485 conversion 8.13
 EIA/TIA 485 8.12 – 8.13
 EIA/TIA 232 8.12 – 8.13
 termination for EIA-232 to EIA-485 converter 8.12
 Condition **6.18**
 Conformity A.4
 Control Output x (1A and 1B) Menu 6.18
 Control Set Points Menu 6.8 – 6.9
 Control Type, Analog Input 2 **6.13**
 Control Type, Analog Input 3 **6.16**
 controller, overview 1.1
 crossover 7.8
 current process input, calibration 5.4
 cursor 2.2
 Custom Main Page 2.3, 4.21, **6.21**
 Custom Main Page Menu 6.21
 Custom Main Page Record 6.25
 customizing the Main Page 4.2
 Cycle Time Type **6.18**
 Cycle Time Value **6.18**

D

dead band 3.2, 7.7

Dead Band x (A or B), Cascade PID 3.3 – 3.4, **6.6**, 7.16
 Dead Band x (A or B), PID Set Channel 1 3.3 – 3.4, **6.5**, 7.16
 Decimal, Analog Input x (1 to 3) **6.13**
 Declaration of Conformity A.4
 default Main Page parameters 2.1
 derivative 7.7
 derivative (rate) time 3.2
 Derivative x (A or B) 3.2
 Derivative x (A or B), Cascade PID 3.3 – 3.4, **6.6**, 7.16
 Derivative x (A or B), PID Set Channel 1 **6.5**
 deviation 3.1
 deviation alarm 3.1, 7.10
 Diagnostic Menu 6.27 – 6.28
 diagnostics, overview 5.3
 Differential Control 7.17
 Differential Set Point **6.2**
 Digital Differential Set Point x (1 to 4) **6.9**
 Digital Input x (1 to 4) Menu 6.17 – 6.18
 digital inputs 7.4
 digital inputs, wiring 8.9
 Digital Ratio Set Point x (1 to 4) **6.9**
 Digital Set Point x (1 to 4) **6.8**, 7.14
 digital set points 7.13
 dimensions 8.1 – 8.2
 Display Test 5.3, **6.28**
 Display Time **6.22**
 displays, front panel 2.2
 cursor 2.2
 Lower Display 2.2
 scroll bar 2.2
 Upper Display 2.2
 displays, overview 2.1 – 2.2
 Down Key 2.2
 droop 7.6 – 7.7
 Duplex **6.18**, 7.13

E

Edit PID 3.2, **6.4** – **6.6**, 7.6 – 7.8
 EIA/TIA 485 and EIA/TIA 232 8.12 – 8.13
 enter key 2.3
 Error Latch **6.15**
 errors

fatal errors 2.5
 input errors 2.5
 system errors 2.6
 troubleshooting 2.4 – 2.6

Event Input — see Digital Inputs x

F

Factory Page 5.1 – 5.6, 6.26 – 6.30
 Factory Page, Set Lockout 5.1, **6.26**
 Fahrenheit or Celsius scale (°F or °C) 4.1, **6.11**
 Failure Mode **6.11**
 Filter Time **6.15**, 7.3
 filter time constant 7.3
 full access 5.1
 Full Defaults 5.3, **6.28**
 Function, Control Output x (1A and 1B) **6.18**
 Function, Digital Input x (1 to 4) **6.17**

G

Glossary **A.5** – **A.7**
 Go to Factory 2.1, **6.3**
 Go to Operations 2.1, **6.3**
 Go to Setup 2.1, **6.3**
 Ground **6.29**
 guided programming 2.3

H

heater life 7.8
 hidden (security level) 5.1
 High Power Limit **6.18**
 High Scale **6.20**, 7.4
 high state 7.4
 hysteresis 7.6
 hysteresis, alarm — see Alarm Hysteresis
 Hysteresis x (A or B), Cascade PID 3.3 – 3.4, **6.6**, 7.16
 Hysteresis x (A or B), PID Set Channel 1 **6.5**

I, J

“i” key 1.2, 2.2
 indicator lights 2.2
 Information Key 1.2, 2.2
 Input 1 Fail **6.12**

Boldface page numbers refer to parameter entries.

input calibration 5.3 – 5.4
input errors 2.5
input offset x (1 to 10) 7.2
input wiring
 analog 8.6 – 8.8
 digital 8.9
input x (1 to 3)
 calibration 5.3 – 5.4
 wiring 8.6 – 8.8
Input x (1 to 3), Diagnostic **6.27-6.28**
Input x (1 to 3) A to D, Diagnostic **6.28**
Input x (1 to 3) Error **6.2**
input-to-output isolation 8.5
inputs and outputs 1.1
 calibration 5.3 – 5.6
 wiring, overview 8.5
installation
 dimensions 8.1 – 8.2
 installing 8.3
 tools required 8.3
integral 7.7
integral (reset) adjustment 3.2
integral action 7.7
integral control 7.7
integral derivative control 7.7
Integral x (A or B), Cascade PID 3.3 – 3.4, **6.5**, 7.16
Integral x (A or B), PID Set Channel 1 **6.4**
isolation barriers 8.5
inverse scaling 7.4

K

keys 2.2, A.13
 Information Key 1.2, 2.2
 Left and Right Keys 2.2
 Up and Down Keys 2.2
keys, displays and navigation, overview 2.1 – 2.2

L

Latching **6.19**
Lead **6.29**
LED Intensity **6.22**
Left Key 2.2
lights
 active output indicator 2.2
 alarm output indicator 2.2
 communications indicator 2.2

Line Frequency **6.28**
linearization 6.12
lock levels 5.1
 Factory Page 5.1
 Operations Page 5.1
 password 5.2
 set point 5.1
 Setup Page 5.1
lockout menu (Set Lockout) 6.26 – 6.27
locks, overview 5.1
Low Power Limit **6.18**
Low Scale **6.20**, 7.4
low state 7.4
Lower Display 2.2

M

Main Page
 Custom Main Page 2.3, 4.2, **6.2**, **6.21**
 error messages on 2.1, 2.5 – 2.6, **6.2**
manual control 6.17
manual operation 2.3
Manual to Auto Transfer 2.3, **6.11**
manual tuning 2.3
Manufacturing Date **6.27**
map, software A.13 – A.14
Maximum Transfer Cool **6.11**
Maximum Transfer Heat **6.11**
Message Display Time **6.17**
Message x (1 to 4) **6.22**
Minimum Transfer Power 7.5
Modbus 9.1-9.13
 exception responses 9.1
 alphabetical list 9.2-9.10
 numerical list 9.11-9.13
Model **6.27**
model number **6.27**, 8.5, A.3
multiple input offsets **6.14**, 7.2
multiple PID sets 3.3 – 3.4, 7.8
multiple tuning procedure 3.2

N

Name, Alarm Output x (1 and 2) **6.19**
Name, Digital Input x (1 to 4) **6.17**
navigation
 keys 2.2
 overview 2.1

noise generation (RFI) 7.8

O

Offset Point x (1 to 10), Input 1 **6.14**
Offset Point x (1 to 10), Input 2 **6.14**
Offset Point x (1 to 10), Input 3 **6.14**
Offset Point Settings 7.2
Offset Type **6.14**
Offset Value x (1 to 10), Input 1 **6.14**
Offset Value x (1 to 10), Input 2 **6.15**
Offset Value x (1 to 10), Input 3 **6.15**
on-off control 7.6
open loop 7.5
Open Loop Detect **6.12**, 7.9
open loop error 7.9
Operations Menu 6.7
Operations Page 3.1 – 3.4, 6.4 – 6.10
Operations Page Parameter Record 6.12
Operations, Alarm Set Point **6.6 – 6.7**
Operations, Alarm Set Point, Set Lockout **6.26**
Operations, Autotune PID **6.4**
Operations, Autotune PID, Set Lockout **6.26**
Operations, Control Set Point Menu 6.8
Operations, Control Set Point, Set Lockout **6.27**
Operations, Edit PID Menu 6.4 – 6.5
Operations, Edit PID, Set Lockout **6.26**
operations, overview 3.1
Operations, PID Crossover **6.7**
Operations, PID Crossover, Set Lockout **6.27**
Operations, Ramp Set Point, Set Lockout **6.27**
Operations, Ramp to Set Point Menu 6.7 – 6.8
Operations, Remote/Local Set Point, Set Lockout **6.27**
operator's display — see Lower Display
output calibration 5.5 – 5.6
output status, indicators 2.2
output wiring 8.10 – 8.11
Output x (1A or 1B), Diagnostic **6.28**
overshoot 7.7

P, Q

- pages, software A.13 – A.14
- parameter records
 - Custom Main Page 6.25
 - Operations Page 6.10
 - Setup Page 6.23 – 6.24
- parameter setup order 4.1
- Parameter x (1 to 16) **6.2, 6.21**
- password lock 5.1
- password, setting or changing 5.2
- PI control 7.7
 - droop 7.7
 - Integral 7.7
 - overshoot 7.7
 - reset 7.7
- PID 7.7
- PID block — see PID Set
- PID control 7.7
 - derivative 7.7
 - autotuning 7.9
- PID Cross **6.7**
- PID Crossover **6.7**
- PID parameters, adjusting manually 3.2
- PID Set x (1 to 5), Cascade PID 3.3 – 3.4, 6.5 – 6.6, 7.16
- PID Set x (1 to 5), PID Set Channel 1 6.4 – 6.5
- PID Units 4.1, **6.11**
- PID, multiple sets 7.8
- power level 7.12
- power wiring 8.5
- Process **6.18**
- process alarm 7.10
- Process Display **6.22**
- Process Display Menu 6.22
- process input, wiring 8.6, 8.8
- process or deviation alarms 3.1, 7.10
- Process Output Calibration 5.5
- process tracking 7.5
- Propband — see Proportional Band
- proportional action 7.6 – 7.7
- Proportional Band x (A or B), Cascade PID 3.3 – 3.4, **6.5, 7.16**
- Proportional Band x (A or B), PID Set Channel 1 3.2, **6.4, 7.6 – 7.7**
- proportional control 7.6 – 7.7
- proportional integral derivative (PID) control 7.7

- proportional plus integral (PI) control 7.7
- proportional plus integral plus derivative (PID) control 7.7
- PV bias — see multiple input offsets

R

- Ramp to Set Point Menu 6.7
- Ramp to Set Point Mode **6.7**
- Ramp to Set Point Rate **6.8**
- Ramp to Set Point Scale **6.8**
- rate alarm 3.1, 7.10
- Rate x (A or B), Cascade PID 3.3 – 3.4, **6.6, 7.16**
- Rate x (A or B), PID Set Channel 1 3.2, **6.5**
- Ratio Control 7.17
- Ratio set point **6.2**
- read only (security level) 5.1
- Records
 - Custom Main Page 6.25
 - Operations Page 6.10
 - Setup Page 6.23 – 6.24
- reference compensator 5.3
- Remote/Local Set Point **6.9**
- Remote Set Point 7.15
- removing the controller 8.4
- reset 7.7
- reset value 7.7
- Reset x (A or B) 3.2
- Reset x (A or B), Cascade PID 3.3 – 3.4, **6.6, 7.16**
- Reset x (A or B), PID Set Channel 1 **6.5**
- resistance temperature detector — see RTD
- Restore Input x (1 to 3) Calibration **6.31**
- restoring factory calibration values 5.3
- retransmit 7.9
- Retransmit Output x (1 and 2) Menu 6.20, 7.4
- Retransmit Outputs
 - calibration 5.6
 - wiring 8.11
- Retransmit Source **6.20**
- Retransmit x (1 or 2) **6.28**
- Reverse outputs **6.17**
- Revision **6.27**

- RFI 7.8
- Right Key 2.2
- rising edge 7.4
- RTD
 - input calibration 5.3 – 5.4
 - inputs, wiring 8.6 – 8.7

S

- safety info *inside front cover*
- Scale High **6.13, 7.4**
- Scale Low **6.13, 7.4**
- Scale Offset **6.20**
- Scaling **6.14, 7.4**
- scroll bar 2.2
- security and locks, overview 5.1
 - passwords 5.2
 - security levels 5.1
 - Set Lockout Menu 6.26 – 6.27
- security levels 5.1
- self tune — see autotune
- self-clearing alarm 7.11
- Sensor **6.12**
- sensor installation guidelines 8.5
 - accuracy ranges A.2
 - process input 8.6, 8.8
 - RTD input 8.6 – 8.7
 - thermocouple inputs 8.6 – 8.7
- Serial Number **6.27**
- Set Lockout Menu 6.26 – 6.27
- Set Point High Limit **6.13**
- Set Point Low Limit **6.13**
- Set Point, Set Lockout **6.26**
- set point
 - locking out 5.1
 - manual tuning 3.2
 - ramping to 6.7 – 6.8
 - remote **6.9, 7.15**
 - static control 2.3
- Set Point **6.26**
- Set Point High Limit **6.13, 7.3**
- Set Point Low Limit **6.13, 7.3**
- set variable — see set point
- Set/Change Password **6.26**
- setup
 - customizing the Main Page 4.2
 - guided 2.3
 - guidelines 4.1
 - overview 4.1
 - parameter record 6.23 – 6.24

- parameter setup order 4.1
 - steps 1.2
- Setup Page 4.1 – 4.2, 6.11 – 6.24
- Setup Page Parameter Record 6.24 – 6.25
- Setup Page, Set Lockout **6.26**
- Show °F or °C **6.11**
- Silencing **6.19**
 - silencing, alarm 7.11
- sine wave 7.8
- Slidewire Control 7.18
- Slidewire Deadband **6.16**
- Slidewire Hysteresis **6.16**
- Slidewire Learn Closed **6.15**
- Slidewire Learn Open **6.16**
- Software Number **6.27**
- software map A.13 – A.14
- solid-state relay, wiring 8.10
- source, alarm — see Alarm Source
- Specifications A.2
- Square Root **6.15**
- Static Message Menu **6.22**
- static set point control — see set point
- system errors 2.6
- System Menu 6.11 – 6.12
- Systeme Internationale (SI) 4.1

T

- technical assistance *inside front cover*
- temperature scale (°F or °C) 4.1, **6.11**
- terminals A.2
- Test Menu 6.28
- Test Outputs **6.28**
- thermocouple
 - input calibration 5.3 – 5.4
 - reference compensator 5.3
 - wiring 8.6 – 8.7
- time filter 7.3
- transformer isolation 8.5
- troubleshooting alarms and errors 2.5
 - 2.6
- Troubleshooting Chart 2.4 – 2.6
- Type, Analog Input x (1 to 3) **6.12**

U

- Units **6.13**
 - PID 4.1, **6.11**
 - SI/U.S. 4.1, **6.11**

- U.S. units 4.1
- Up Key 2.2
- Upper Display 2.2

V

- values, how to enter 2.3
- voltage process input calibration 5.4

W

- warranty *inside back cover*
- wiring
 - communications 8.12 – 8.13
 - inputs 8.6 – 8.9
 - outputs 8.10 – 8.11
 - overview 8.5
 - power 8.5
 - retransmit and alarm 8.11
- wiring example 8.14
- wiring notes 8.15

X, Y, Z

- zero-cross switching (burst fire) 7.8

Series F4P Software Map

For ranges, defaults, Modbus numbers and other information about the parameters, refer to the Parameter Tables in Chapter 6.

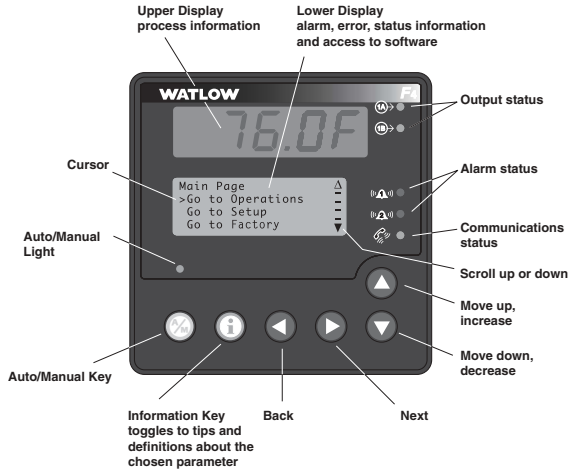

Main Page see Chapter 2

- Input x (1 to 3) Error
- Alarm x (1 to 2) Condition
- Parameter x (1 to 16)
 - Process 1 Value
 - Process 1 Value bar graph
 - Set Point 1 (or Idle Set Point)
 - Set Point 1 (or Idle Set Point) value bar graph
 - Remote Set Point 2
 - Remote Set Point 3
 - Output 1A Power
 - Output 1A Power bar graph
 - Output 1B Power
 - Output 1B Power bar graph
 - Autotuning
 - Time Remaining
 - Active PID Set
 - Go to Operations
 - Go to Setup
 - Go to Factory

Operations Page see Chapter 3

- Autotune PID
 - Channel 1 Autotune
 - Autotune PID Type
 - Autotune Cascade PID
 - Cascade Inner Loop
 - Cascade Outer Loop
- Edit PID
 - PID Set x (1 to 5) (Optional Inner Loop)
 - Proportional Band A
 - Integral A / Reset A
 - Derivative A / Rate A
 - Dead Band A
 - Hysteresis A
 - Proportional Band B
 - Integral B / Reset B
 - Derivative B / Rate B
 - Dead Band B
 - Hysteresis B
 - Cascade Outer Loop PID Set x (1-5)
 - Proportional BandA
 - Integral A / ResetA
 - Derivative A / RateA
 - Dead Band A
 - Hysteresis A
 - Proportional Band B
 - Integral B / ResetB
 - Derivative B / RateB
 - Dead Band B
 - Hysteresis B
- Alarm Set Points
 - Alarm Low Set Point
 - Alarm High Set Point
 - Alarm Low Deviation
 - Alarm High Deviation
 - Alarm Maximum Low Rate
 - Alarm Maximum High Rate
- PID Crossover
 - PID Crossover
 - PID Cross x
- Ramp x to Set Point
 - Ramp to Set Point Mode
 - Ramp to Set Point Scale
 - Ramp to Set Point Rate
- Control Set Points
 - Boost Power
 - Boost Delay Time
 - Boost Set Point
 - Digital Set Point x (1 to 4)
 - Digital Differential Set Point x (1 to 4)
 - Digital Ratio Set Point x (1 to 4)
- Remote/Local Set Points
 - Remote/Local Set Point

Setup Page see Chapter 4

- System
 - PID Units
 - °F or °C
 - Show °F or °C
 - Maximum Transfer Heat
 - Maximum Transfer Cool
 - Manual to Auto Transfer
 - Autotune Set Point
 - Failure Mode
 - Input 1 Fail
 - Open Loop Detect
- Analog Input x (1 to 3)
 - Sensor
 - Type
- Analog Input 2
 - Control Type
- Analog Input x (1 to 3) continued
 - Units
 - Decimal
 - Scale Low
 - Scale High
 - Scaling
 - Set Point Low Limit
 - Set Point High Limit
 - Offset Type
 - Calibration Offset Value
 - Clear Input x (1 to 3) Offsets
 - Offset Point x (1 to 10)
 - Offset Value x (1 to 10)
 - Filter Time
 - Error Latch
 - Square Root
- Analog Input 3
 - Auto/Manual Slidewire Calibration
 - Slidewire Learn Closed
 - Slidewire Learn Open
 - Slidewire Deadband
 - Slidewire Hysteresis
 - Control Type
 - Cascade
 - Cascade Low Range, Process
 - Cascade High Range, Process
 - Cascade Low Deviation Range
 - Cascade High Deviation Range
- Digital Input x (1 to 4)
 - Function
 - Name
 - Activate Message
 - Message Display Time
 - Condition
- Control Output x (1A, 1B)
 - Function
 - Cycle Time Type
 - Cycle Time Value
 - Process
 - Duplex (1A)
 - High Power Limit
 - Low Power Limit
 - Boost Type (1B)
 - Boost Power Mode (1B)
 - Boost Set Point Type (1B)
- Alarm Output x (1 and 2)
 - Name

- Alarm Type
- Alarm Source
- Latching
- Silencing
- Alarm Hysteresis
- Alarm Sides
- Alarm Logic
- Alarm Messages
- Retransmit Output x (1 and 2)
 - Retransmit Source
- Analog Range
 - Low Scale
 - High Scale
 - Scale Offset
- Communications
 - Baud Rate
 - Address
- Custom Main Page
 - Parameter x (1 to 16)
- Process Display
 - Display Time
 - LED Intensity
- Static Message
 - Message x (1 to 4)

Factory Page see Chapter 5

- Set Lockout
 - Set Point
 - Oper. Autotune PID
 - Oper. Edit PID
 - Oper. Alarm SP
 - Setup Page
 - Factory Page
 - Set/Change Password
 - Clear Locks
 - Oper. PID Crossover
 - Oper. Ramp Set Point
 - Oper. Control Set Point
 - Oper. Remote/Local Set Point
- Diagnostic
 - Model
 - Mfg Date
 - Serial #
 - Software #
 - Revision
 - In x (1 to 3)
 - Out x (1A or 1B)
 - Retrans x (1 or 2)
 - In x (1 to 3) A to D
 - CJC (1 to 3) A to D
 - CJC (1 to 3) Temp
 - Line Freq
- Test
 - Test Outputs
 - Display Test
 - Full Defaults
- Calibration
 - Calibrate Input x (1 to 3)
 - Calibrate Output x (1A or 1B)
 - Calibrate Rexmit x (1 or 2)
 - Restore In x (1 to 3) Cal

About Watlow Winona

Watlow Winona is a U.S. division of Watlow Electric Mfg. Co., St. Louis, Missouri, a manufacturer of industrial electric heating products since 1922. Watlow products include electric heaters, sensors, controllers and switching devices. The Winona operation has been designing solid-state electronic control devices since 1962, and has earned the reputation as an excellent supplier to original equipment manufacturers. These OEMs and end users depend upon Watlow Winona to provide compatibly engineered controls that they can incorporate into their products with confidence. Watlow Winona resides in a 100,000-square-foot marketing, engineering and manufacturing facility in Winona, Minnesota.

Warranty

The Watlow Series F4P is warranted to be free of defects in material and workmanship for 36 months after delivery to the first purchaser for use, providing that the units have not been misapplied. Since Watlow has no control over their use, and sometimes misuse, we cannot guarantee against failure. Watlow's obligations hereunder, at Watlow's option, are limited to replacement, repair or refund of purchase price, and parts which upon examination prove to be defective within the warranty period specified. This warranty does not apply to damage resulting from transportation, alteration, misuse, or abuse.

Returns

1. Call Watlow Customer Service, (507) 454-5300, for a Return Material Authorization (RMA) number before returning any item for repair. We need the following information:
 - Ship to address
 - Contact name
 - Method of return shipment
 - Detailed description of the problem
 - Name and phone number of the person returning the product
 - Bill to address
 - Phone number
 - Your P.O. number
 - Any special instructions
2. Prior approval and an RMA number, from the Customer Service Department, is required when returning any unused product for credit. Make sure the RMA number is on the outside of the carton, and on all paperwork returned. Ship on a Freight Prepaid basis.
3. After we receive your return, we will examine it and determine the cause for your action.
4. In cases of manufacturing defect, we will enter a repair order, replacement order or issue credit for material returned.
5. To return products that are not defective, goods must be in new condition, in the original boxes and they must be returned within 120 days of receipt. A 20 percent restocking charge is applied for all returned stock controls and accessories.
6. If the unit is unrepairable, it will be returned to you with a letter of explanation. Repair costs will not exceed 50 percent of the original cost.
7. Watlow reserves the right to charge for no trouble found (NTF) returns, not to exceed 20 percent of the original net price.

How to Reach Us

Corporate Headquarters

Watlow Electric Manufacturing Company
12001 Lackland Road
St. Louis, MO 63146
Sales: 1-800-WATLOW2
Manufacturing Support: 1-800-4WATLOW
Email: info@watlow.com
Website: www.watlow.com
From outside the USA and Canada:
Tel: +1 (314) 878-4600
Fax: +1 (314) 878-6814

Latin America

Watlow de México S.A. de C.V.
Av. Fundición No. 5
Col. Parques Industriales
Querétaro, Qro. CP-76130
Mexico
Tel: +52 442 217-6235
Fax: +52 442 217-6403

Europe

Watlow France
Tour d'Asnières.
4 Avenue Laurent Cély
92600 Asnières sur Seine
France
Tél: + 33 (0)1 41 32 79 70
Télécopie: + 33(0)1 47 33 36 57
Email: info@watlow.fr
Website: www.watlow.fr

Watlow GmbH
Postfach 11 65, Lauchwasenstr. 1
D-76709 Kronau
Germany
Tel: +49 (0) 7253 9400-0
Fax: +49 (0) 7253 9400-900
Email: info@watlow.de
Website: www.watlow.de

Watlow Italy S.r.l.
Viale Italia 52/54
20094 Corsico MI
Italy
Tel: +39 024588841
Fax: +39 0245869954
Email: italyinfo@watlow.com
Website: www.watlow.it

Watlow Ibérica, S.L.U.
C/Marte 12, Posterior, Local 9
E-28850 Torrejón de Ardoz
Madrid - Spain
T. +34 91 675 12 92
F. +34 91 648 73 80
Email: info@watlow.es
Website: www.watlow.es

Watlow UK Ltd.
Linby Industrial Estate
Linby, Nottingham, NG15 8AA
United Kingdom
Telephone: (0) 115 964 0777
Fax: (0) 115 964 0071
Email: info@watlow.co.uk
Website: www.watlow.co.uk
From outside The United Kingdom:
Tel: +44 115 964 0777
Fax: +44 115 964 0071

Asia and Pacific

Watlow Singapore Pte Ltd.
16 Ayer Rajah Crescent,
#06-03/04,
Singapore 139965
Tel: +65 6773 9488 Fax: +65 6778
0323
Email: info@watlow.com.sg
Website: www.watlow.com.sg

Watlow Australia Pty., Ltd.
4/57 Sharps Road
Tullamarine, VIC 3043
Australia
Tel: +61 3 9335 6449
Fax: +61 3 9330 3566
Website: www.watlow.com

Watlow Electric Manufacturing Company
(Shanghai) Co. Ltd.
Room 501, Building 10, KIC Plaza
290 Songhu Road, Yangpu District
Shanghai, China 200433
China
Phone:
Local: 4006 Watlow (4006 928569)
International: +86 21 3381 0188
Fax: +86 21 6106 1423
Email: vlee@watlow.cn
Website: www.watlow.cn

ワトロー・ジャパン株式会社
〒101-0047 東京都千代田区内神田1-14-4
四国ビル別館9階
Tel: 03-3518-6630 Fax: 03-3518-6632
Email: infoj@watlow.com Website:
www.watlow.co.jp
Watlow Japan Ltd.
1-14-4 Uchikanda, Chiyoda-Ku
Tokyo 101-0047
Japan
Tel: +81-3-3518-6630 Fax: +81-3-
3518-6632
Email: infoj@watlow.com Website:
www.watlow.co.jp

Watlow Korea Co., Ltd.
#1406, E&C Dream Tower, 46,
Yangpyeongdong-3ga
Yeongdeungpo-gu, Seoul 150-103
Republic of Korea
Tel: +82 (2) 2628-5770 Fax: +82 (2)
2628-5771
Website: www.watlow.co.kr

Watlow Malaysia Sdn Bhd
1F-17, IOI Business Park
No.1, Persiaran Puchong Jaya Selatan
Bandar Puchong Jaya
47100 Puchong, Selangor D.E.
Malaysia
Tel: +60 3 8076 8745 Fax: +60 3
8076 7186
Email: vlee@watlow.com
Website: www.watlow.com

瓦特龍電機股份有限公司
80143 高雄市前金區七賢二路189號 10樓
之一
電話: 07-2885168 傳真: 07-2885568
Watlow Electric Taiwan Corporation
10F-1 No.189 Chi-Shen 2nd Road
Kaohsiung 80143
Taiwan
Tel: +886-7-2885168 Fax: +886-7-
2885568

Your Authorized Watlow Distributor

TOTAL
CUSTOMER
SATISFACTION
3 Year Warranty