

Eurotherm®

Precision at the heart of your process



Eurotherm EPC3000 programmable controller

Benefits

The EPC3000 range of panel mounted programmable single loop PID controllers aids optimization of production yield for thermal and other forms of processing.

Designed with native, high speed Ethernet, and Achilles Level 1 certified for resilience against cyber-attack, the EPC3000 range is an ideal component for digitized Industry 4.0 and “Industrial Internet of Things” applications.

Highly configurable, with precise, repeatable control and measurement performance, meeting accuracy specifications up to and including stringent aerospace regulatory requirements, the EPC3000 range remains simple to use and deploy.

Key features and options

- Enhanced Eurotherm PID control with cutback function for fast response and minimal overshoot
- Precision 0.1% Inputs meeting accuracy requirements of AMS2750F and CQI-9
- Wireable function blocks including math, logic, and advanced control
- Fast Ethernet with RJ45 connector for IIoT and Industry 4.0
- Modbus, Ethernet/IP and BACnet protocol support
- Up to 20 ramp/soak program profiles
- Factory Mutual (FM) approved temperature limit option available

eurotherm.com/epc3000

 **WATLOW®**
Powered by Possibility

Specifications

General	
Controller Function	<ul style="list-style-type: none"> • Single loop panel mount PID controller range with autotune, on/off and valve positioning (no slidewire required). • Zirconia probe atmosphere control. • Single loop profile/program. • AC Mains voltage and 24Vdc power options.
Measurement Inputs	1 or 2 inputs. Accuracy $\pm 0.1\%$ of reading (refer to Universal Inputs table).
PID Control	<ul style="list-style-type: none"> • 2 PID sets are available as standard, with 8 as an optional extension (Each PID set offers a separate proportional band for heat and cool operation). • Enhanced Autotuning control with cutback function to minimize overshoot and oscillation. Fast reacting precision control to setpoint changes or after process disturbances. • Enhanced valve positioning (unbounded) algorithm. • Gain scheduling allows PID selection for a wide range of operating situations, including deviation from setpoint, absolute temperature, output level and others. • AC supply voltage monitoring for feedforward function. Process Variable (PV) and Setpoint (SP) feedforward functions.
Setpoint Programmer/Profiler (not available for the FM version)	<ul style="list-style-type: none"> • Options include 20 profiles of 8 steps (20x8), 10x24, 1x24 and 1x8. • Holdback ("guaranteed soak"), event outputs, time to target, ramp rate, dwell, step and call segment types. • Communication addresses are compatible with Eurotherm 2400 Programmable Controller. • Additional timer functions are available.
User Function Block Wiring	<ul style="list-style-type: none"> • Optional totalizer • Math • Logic and multiplexing • BCD conversion • Counter/timer and many other special function blocks available including 16 point linearization, zirconia and dual input switchover.
Limit Functions	<ul style="list-style-type: none"> • EN ISO 13849-1: Performance Level (PL) "C" for PV input to Alarm function • EN 14597 TR approved • Meets Factory Mutual (FM) Approval Standard for Temperature Limit and Supervisory Switches Class Number 3545 (when FM type selected).
Additional Functions	<ul style="list-style-type: none"> • Digital and analog retransmission functions. • CT Input - Monitor partial load failure, load short and open circuit; Dual input functions including switchover, redundant sensor, average, min, max, zirconia. • 6 freely configurable alarms with manual, automatic, non-latching and event types plus alarm delay function and blocking. • Alarms may be inhibited in standby. • 5 Recipes with 40 freely selectable parameters switchable from the front panel or digital input. • Scrolling parameter help and user messages displayed on event.
Backup and Configuration Tools	<ul style="list-style-type: none"> • Free Eurotherm iTools software for backup and configuration. • USB Backup cable available for convenient desktop configuration and back up; powers the instrument with or without a sleeve. • iTools also connects using Ethernet Modbus/TCP and serial Modbus RTU.
"OEM Security"	Helps protect instrument configurations from unauthorized viewing, cloning or backwards engineering.

Specifications

Function Blocks	Function	Standard	Standard Toolkit Blocks	Enhanced Toolkit Blocks
Instrument	Interface to Instrument wide settings	1	-	-
Loop	Enhanced Eurotherm PID Loop	1	-	-
Programmer*	Ramp/Dwell Programmer	1	-	-
BCD	BCD Conversion	1	-	-
Alarm	General purpose analog alarm monitoring	6	-	-
Recipe	General purpose recipe function	1	-	-
Comms*	Interface to serial and Ethernet communications	2	-	-
AI	Interface to main analog input	2	-	-
IP Monitor	Input monitoring (min, max, other functions)	2	-	-
IO*	Interface to Inputs and Outputs	6	-	-
Option DIO*	Digital I/O options	8	-	-
Remote Input	Interface to remote (communications) input	1	-	-
OR	Eight input logical "OR" operation	8	-	-
CT*	Current transformer	1	-	-
Zirconia*	Zirconia Probe input	1	-	-
Wires*	User wiring	50	200	200
Math2	Two input math functions	-	4	8
Lgc2	Two input logical operations	-	4	8
Lgc8	Eight input logical operations	-	2	4
Timer	Timer based functions	-	1	2
SwitchOver	Input switchover	-	1	1
Mux8	Eight Input multiplexer	-	3	4
Total	Totalizer	-	1	1
Counter	Counter block (32-bit)	-	1	2
UsrVal	User values (freely assignable)	-	4	12
Lin16	16 point linearization	-	2	2

*Dependent on instrument/options ordered

Specifications

Environmental Specifications, Standards Approvals and Certifications	
Operating Temperature	0 to 55°C (32 to 131°F)
Storage Temperature	-20 to +70°C (-4 to 158°F)
Operating/Storage Humidity	5% to 90% RH non-condensing
Atmosphere	Non-corrosive, non-explosive
Altitude	<2000 meters (6562 feet)
Vibration and Shock	EN 61131-2 (5 to 11.9Hz @ 7mm peak to peak displacement, 11.9-150Hz @ 2g, 0.5 octave min.) EN 60068-2-6 Test FC, Vibration. EN 60068-2-27 Test Ea and guidance, Shock.
Front of Panel Sealing Protection	Standard bezel: EN 60529 IP65, UL50E Type 12 (equivalent to NEMA 12) Washdown bezel: EN 60529 IP66, UL50E Type 4X (indoor use) (equivalent to NEMA 4X)
Rear of Panel Protection	EN 60529 IP10
Electromagnetic Compatibility (EMC)	Emissions HV Power Supply units to EN 61326-1 Class B – Light industrial LV Power Supply units to EN 61326-1 Class A – Heavy industrial Immunity EN 61326-1 Industrial
Approvals and Certification	Europe CE, RoHS (EN 50581), REACH, WEEE, EN 14597 TR Type Approval
	USA, Canada UL, cUL. Factory Mutual (FM) Approval Standard for Temperature Limit and Supervisory Switches Class Number 3545 October 98
	China RoHS, CCC: Exempt (Product not listed in catalog of products subject to China Compulsory Certification)
	General When subject to the necessary field calibration, EPC3000 series controllers manufactured by Eurotherm are suitable for use in Nadcap applications in all furnace classes, as defined in AMS2750F clause 3.3.1. Meets accuracy requirements of CQI-9 Achilles® Level 1 CRT Cyber Security Assessment EN ISO 13849-1 Performance Level "C"
Electrical Safety	EN 61010-1 (installation category II, pollution degree 2)

Mechanical details

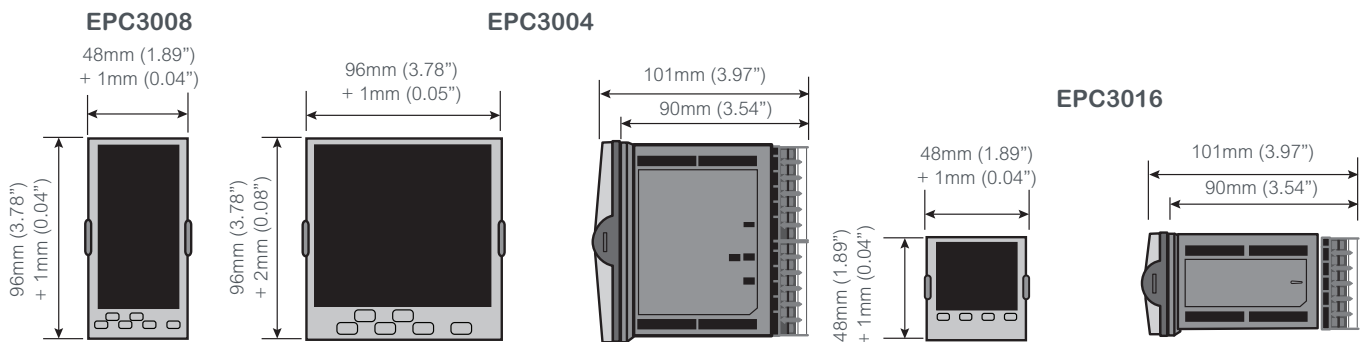

Panel cut out and Weight			
	EPC3008	EPC3004	EPC3016
Cut Out Dimension	92mm (-0.0 +0.8) x 45mm (-0.0 +0.6) 3.62" (-0.0 +0.03) x 1.77" (-0.0 +0.02)	92mm (-0.0 +0.8) x 92mm (-0.0 +0.8) 3.62" (-0.0 +0.03) x 3.62" (-0.0 +0.03)	45mm (-0.0 +0.6) x 45mm (-0.0 +0.6) 1.77" (-0.0 +0.02) x 1.77" (-0.0 +0.02)
Product Weight	350g 12.34oz	420g 14.81oz	250g 8.81oz

Specifications

Inputs and outputs

I/O and communication types

I/O and Comms	EPC3016	EPC3008/EPC3004
Analog Inputs	<ul style="list-style-type: none"> • 1 universal input 20Hz • 1 auxiliary input 4-20mA, 0-10V 4Hz (option) 	<ul style="list-style-type: none"> • 1 or 2 (option) universal input 20Hz
Optional I/O Modules:	Up to 2, freely selectable: <ul style="list-style-type: none"> • Form A Relay Output • Logic I/O • DC Analog Output • TRIAC Output 	Up to 3, freely selectable: <ul style="list-style-type: none"> • Form A Relay Output • Logic I/O • DC Analog Output • TRIAC Output
Form C Relay Output	1	1
Contact Closure Logic Input	1 (option)	2
Logic I/O (Open Collector)	–	4 or 8 (option)
Current Transformer	1 (option)	1
24V Transmitter Power Supply	–	1
Communications	1 of the following options: <ul style="list-style-type: none"> • EIA-485 • EIA-422 • EIA-232 • Modbus RTU slave (EI Bisynch available with serial comms) • Modbus TCP slave • Modbus TCP Slave + EtherNet/IP Server, or Modbus TCP Slave + BACnet Slave • Modbus TCP Master and Slave 	2 of the following options: <ul style="list-style-type: none"> • EIA-485 • Modbus (or EI Bisynch) and Modbus TCP • Modbus TCP Slave + EtherNet/IP Server, or Modbus TCP Slave + BACnet Slave • Modbus TCP Master and Slave

I/O Specifications

Universal Process Inputs	
Input Types	Thermocouples, Pt100/Pt1000 RTD, 4-20mA, 0-20mA, 10V, 2V, 0.8V, 80mV, 40mV, zirconia (oxygen probe), pyrometers. For other input types, contact your Eurotherm supplier for advice. Accuracy $\pm 0.1\%$ of reading. When subject to the necessary field calibration, EPC3000 series controllers manufactured by Eurotherm are suitable for use in Nadcap applications in all furnace classes as defined in AMS2750F clause 3.3.1. For further information see eurotherm.com/certificates .
Sample Time	<ul style="list-style-type: none"> • Process Inputs 50ms (20Hz) • Thermocouple 62.5ms (16Hz) • RTD 100ms (10Hz) • Automatic cycle time selection
Mains Rejection (48-62Hz)	<ul style="list-style-type: none"> • Series mode rejection >80dB. • Common mode rejection >150dB
Sensor Break	AC sensor break. Break detected within 3 seconds worst case.
Input Filtering	OFF to 60 seconds filter time constant.
User Calibration	User 2 point input adjust (offset/gradient), transmitter output scaling.
Thermocouple	<ul style="list-style-type: none"> • K, J, N, R, S, B, L, T as standard, plus 2 downloadable custom curves • Linearization accuracy: refer to User Guide • Cold Junction (CJ) calibration accuracy: $\pm 1.0^{\circ}\text{C}$ at 25°C ($\pm 1.8^{\circ}\text{F}$ at 77°F) ambient • CJ ambient rejection ratio: better than 40:1 from 25°C ambient • External CJ selectable as 0, 45, 50°C or measurable for EPC3004/EPC3008

Specifications

Inputs and outputs

Input Ranges	40mV	80mV	0.8V	2V	10V	RTD (Pt100/ Pt1000)	mA
Range Min	-40mV	-80mV	-800mV	-2V	-10V	0Ω (-200°C; -328°F)	-32mA
Range Max	+40mV	+80mV	+800mV	+2V	+10V	400Ω /4000Ω (850°C; 1562°F)	+32mA
Thermal Stability from 25°C (77°F) Ambient	±0.4μV/°C ±13ppm/°C	±0.4μV/°C ±13ppm/°C	±0.4μV/°C ±13ppm/°C	±0.4μV/°C ±13ppm/°C	±0.8μV/°C ±70ppm/°C	±0.01°C/°C ±25ppm/°C	±0.16μA/°C ±113ppm/°C
Resolution	1.0μV unfiltered	1.6μV	16μV	41μV	250μV	0.05 °C (0.09 °F)	0.6μA
Electrical Noise (peak to peak with 1.6s input filter)	0.8μV	3.2μV	32μV	82μV	250μV	0.05 °C (0.09 °F)	1.3μA
Linearity Accuracy (best fit straight line)	0.003%	0.003%	0.003%	0.003%	0.007%	0.033%	0.003%
Calibration Accuracy @25°C (77°F) ambient	±4.6μV ±0.053%	±7.5μV ±0.052%	±75μV ±0.052%	±420μV ±0.044%	±1.5mV ±0.063%	±0.31°C (0.56°F) ±0.023%	±3μA ±1.052%
Input Resistance	100MΩ	100MΩ	100MΩ	100MΩ	57kΩ	-	2.49Ω (1% Shunt)
Bulb Current	-	-	-	-	-	190μA/ 180μA	-

Remote Setpoint Auxiliary Analog Input (3016 Only)

Range	0 to 10V and 4 to 20mA. Max ranges -1V to 11V and 3.36mA to 20.96mA
Accuracy	<±0.25% of reading ± 1LSD, 14 Bits
Sample Rate	4Hz (250ms)
Functions	<ul style="list-style-type: none"> • Remote setpoint input • Auxiliary analog input
Thermal Stability	100ppm (typical) < 150ppm (worst case)
Mains Rejection	Common Mode 48-62Hz > 120dB, Series Mode > 90dB
Input Impedance	Voltage 223kΩ. Current 2.49Ω

Current Transformer Input

Input Range	<ul style="list-style-type: none"> • 0-50mA RMS, 48-62Hz • 10Ω burden resistor fitted inside module
Measurement Scaling	10, 25, 50 or 100 Amps
Calibration Accuracy	<1% of reading (typical) <4% of reading (worst case)
Input Functions	<ul style="list-style-type: none"> • Partial load failure. SSR open or short circuit. • Other functions including power usage totalization available using soft wiring.

Contact Closure Logic Inputs

Thresholds	Open > 400Ω, Closed < 100Ω
Input Functions	<ul style="list-style-type: none"> • Auto/Manual select • SP2 select • Integral hold • Control inhibit • Program run functions • Keylock • Recipe select • PID select • BCD bit • Autotune enable • Standby • PV select plus other functions available using soft wiring.

Inputs and outputs

Logic I/O Modules	
Output Rating	ON 12Vdc 44mA max. Minimum control cycle time 50ms (auto)
Output Functions	Time proportioned heat, time proportioned cool. SSR drive alarm and event outputs, interlock outputs, other functions available using soft wiring.
Contact Closure (input)	Open 500Ω, Closed 150Ω
Input Functions	<ul style="list-style-type: none"> • Auto/Manual select • SP2 select • Integral hold • Control inhibit • Program run functions • Keylock • Recipe select • PID select • BCD bit • Autotune enable • Standby • PV select plus other functions available using soft wiring.

Logic I/O Open Collector Type (EPC3004/EPC3008 only)	
External DC Power Supply	15V to 35Vdc
Output Limit	Maximum current sinking 40mA
Output Functions	Alarm and event outputs, interlock outputs, other functions available using soft wiring. Cannot be used as a control output.
Voltage Sensing Input	OFF < 1V, ON > 4V. Max 35V, Min -1V
Contact Closure Input	OFF > 28KΩ, ON < 100Ω
Input Functions	<ul style="list-style-type: none"> • Auto/Manual select • SP2 select • Integral hold • Control inhibit • Program run functions • Keylock • Recipe select • PID select • BCD bit • Autotune enable • Standby • PV select plus other functions available using soft wiring.

Relays (Form A Modules and Form C built in)	
Types	Form A (normally open) Form C (changeover)
Output Functions	Time proportioned heat, time proportioned cool. SSR drive. Direct valve raise/lower. Alarm and event outputs, interlock outputs, other functions available using soft wiring.
Rating	Min 100mA @ 12V, Max 2A @ 264V AC resistive. External suppression device ("snubber") recommended.

TRIAC Module	
Rating	Min 40mA, 30V RMS, Max 0.75A @ 264V AC resistive.
Output Functions	Time proportioned heat, time proportioned cool. SSR drive alarm and event outputs, interlock outputs, other functions available using soft wiring.
Surge Rating	Max current surge 30A (<10ms) Max continuous operating voltage 540V peak, 385V RMS. Max surge voltage 800V peak, 565V RMS (< 10ms).

Isolated DC Analog Output Module		
	Current Output	Voltage Output
Range	0-20mA	0-10V
Load Resistance	<550Ω	>450Ω
Calibration Accuracy	±(0.5% of reading + 100μA offset)	±(0.5% of reading + 50mV offset)
Resolution	13.5 bit resolution	13.5 bit resolution
Output Functions	<ul style="list-style-type: none"> • SCR/Power control drive • Proportional valve • Retransmission to chart recorder or other instrumentation • Other functions using soft wiring 	
Digital Input (DI), where configured	The DC output module can be configured as contact closure input see "I/O List (io)" in User Guide (HA032842). In this case: <ul style="list-style-type: none"> • Retransmission to chart recorder or other instrumentation • Other functions using soft wiring 	

Specifications

Power, communications and operator interface

Power and transmitter power supply

Power Supply, AC Supply Measurement and Transmitter Power Supply	
Controller Supply Voltage	100-230Vac +/- 15%, 48 to 62Hz or 24Vac +10%/-15%, 48 to 62Hz or 24Vdc +20%/-15%, max 5% ripple voltage.
Power Supply Rating	EPC3016 Controller 6W EPC3008/3004 Controller 9W
Power Measurement	Only available in 100-230Vac powered instruments. Measures direct from power supply (no additional connections). Uncalibrated. Electrical noise 0.5V filtered, used by the PID function for power feedforward.
Transmitter Power Supply	24Vdc. 2 to 28mA load. Isolated from system (300V AC double insulation) (EPC3004/EPC3008 only)

Communications

Communications	
Ethernet	<ul style="list-style-type: none">• Shielded grounded RJ45 connection supporting 10/100BASE-T auto-sensing• Certified to Achilles® communications robustness testing level 1• Modbus/TCP, BACnet and EtherNet/IP Protocols• Fixed IP address or DHCP• Bonjour Auto-Discovery
Serial	<ul style="list-style-type: none">• EIA-485 Half duplex• EIA-422/EIA-232 Full duplex• Baud Rates 4800 (EI-Bisynch only), 9600, 19200• Modbus RTU 8 data bits, odd/even/no parity selectable• EI-Bisynch 7 data bits even parity fixed

Operator Interface

Display and Operation	
Type	High visibility LCD with backlight. Flat "washdown" membrane bezel with superior panel sealing, or sculpted bezel with fully tactile keys.
Keyboard	100,000 operations typical
Main PV	<ul style="list-style-type: none">• EPC3016 4 digits, 3 decimal places• EPC3008 4.5 digits, 4 decimal places• EPC3004 5 digits, 4 decimal places; green/red bicolor (red in alarm)
Second Line (EPC3004/EPC3008 only)	5 character 16 segment text or numeric
Third Line	16 segment scrolling text or numeric display
Text Character sets	Roman, Simplified Cyrillic <ul style="list-style-type: none">• Program status indicator (ramp up, ramp down or dwell)• Output indicators
Additional Display Functions	<ul style="list-style-type: none">• Alarm indication• Units• Bar graph (EPC3004, EPC3008 Controllers only)• Communications activity indicator
HMI Functions	<ul style="list-style-type: none">• Configurable display contents• Configurable scroll lists for operator/supervisor• Configurable scrolling event messages• Passcode level protection with lockout period• 2 Programmable function keys (EPC3004, EPC3008 Controllers only)

Specifications

EPC3008/EPC3004 isolation

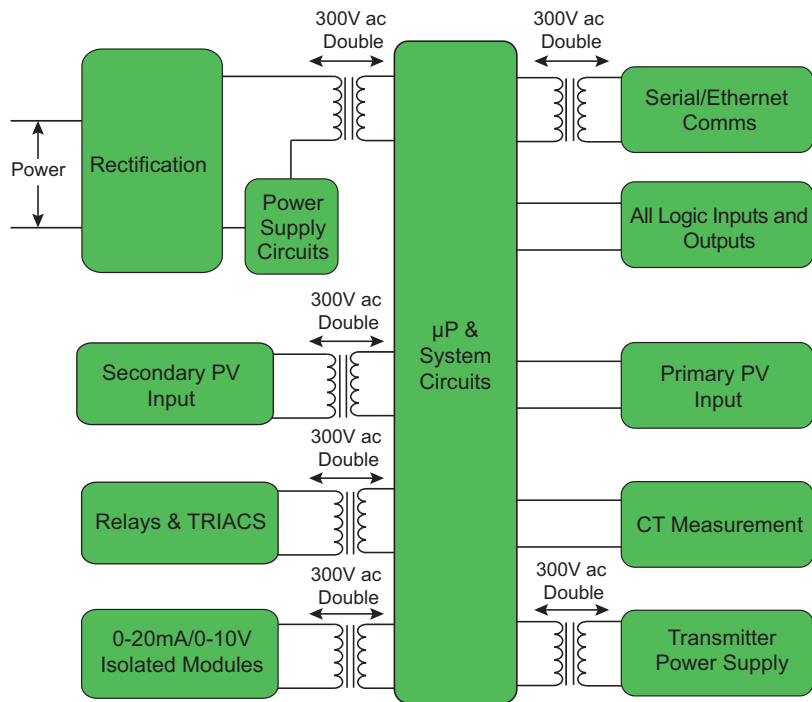

EPC3016 isolation

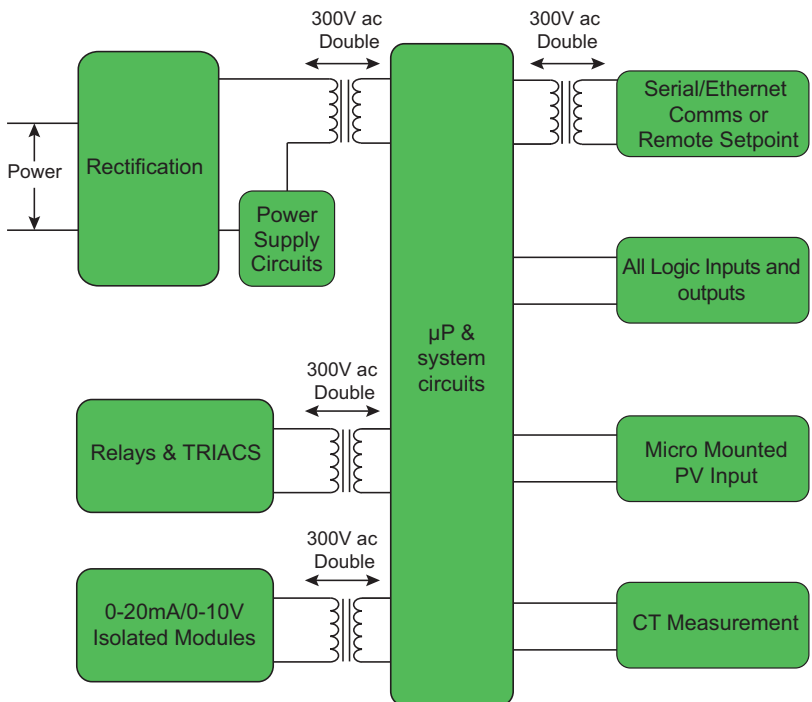

Specifications

Rear terminals

EPC3016

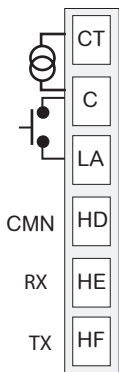
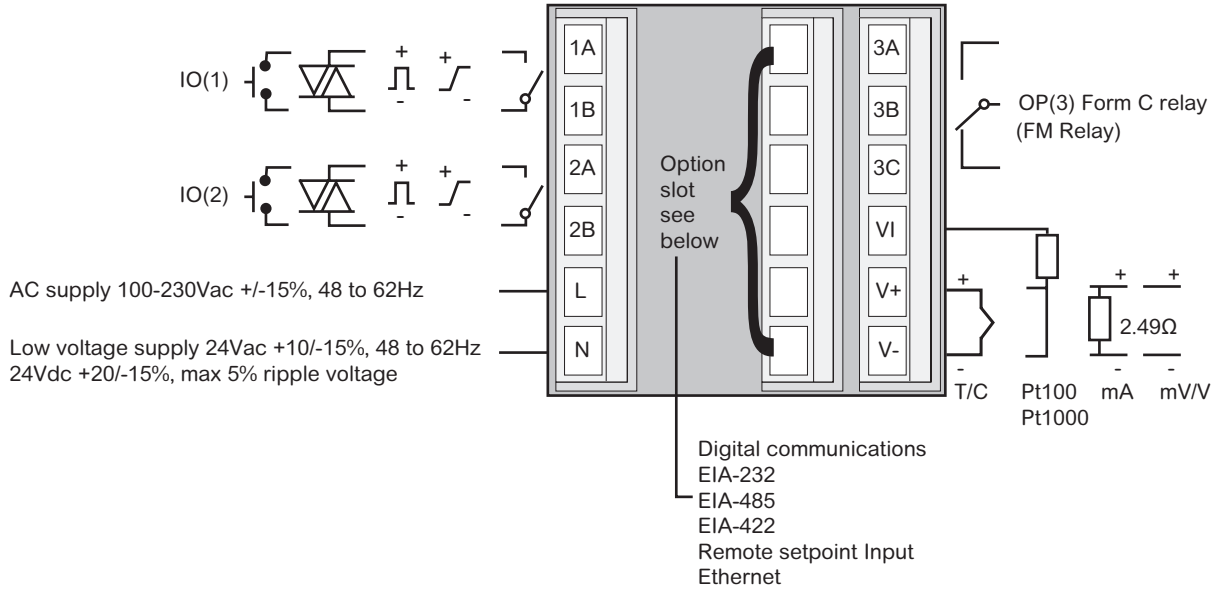

EIA-232
CT INPUT
DIGITAL INPUT

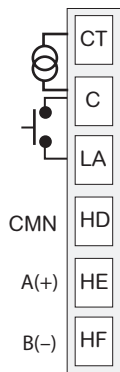

EIA-485
CT INPUT
DIGITAL INPUT



EIA-422

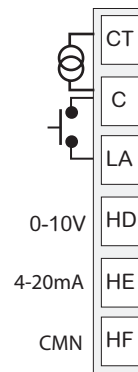

RSP INPUT
CT INPUT
DIGITAL INPUT

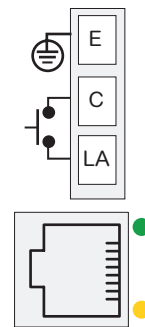

ETHERNET
DIGITAL INPUT

Key to Symbols Used in Wiring Diagrams

	Logic Output (SSR drive)		Relay Output		Contact Input
	0-10V/0-20mA Analog Output		TRIAC Output		Current Transformer Input

Specifications

Rear terminals

EPC3004 / EPC3008

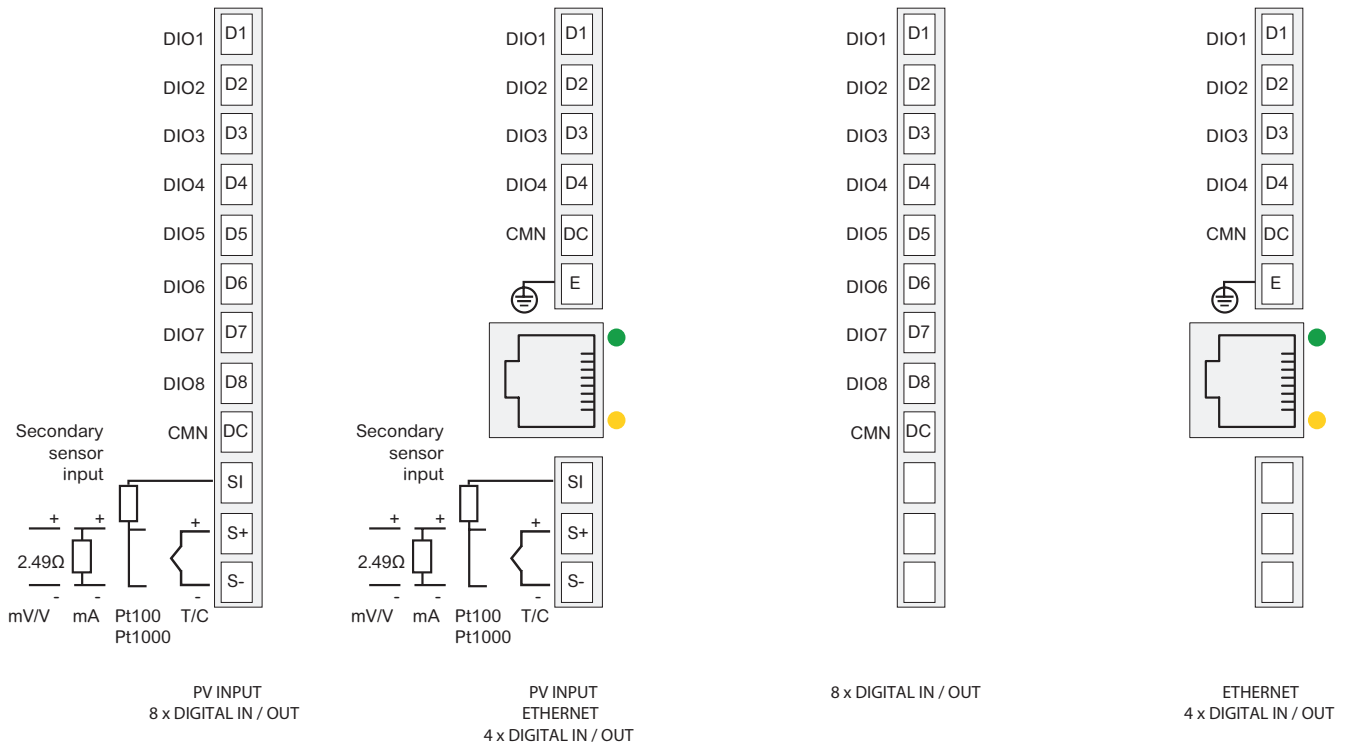
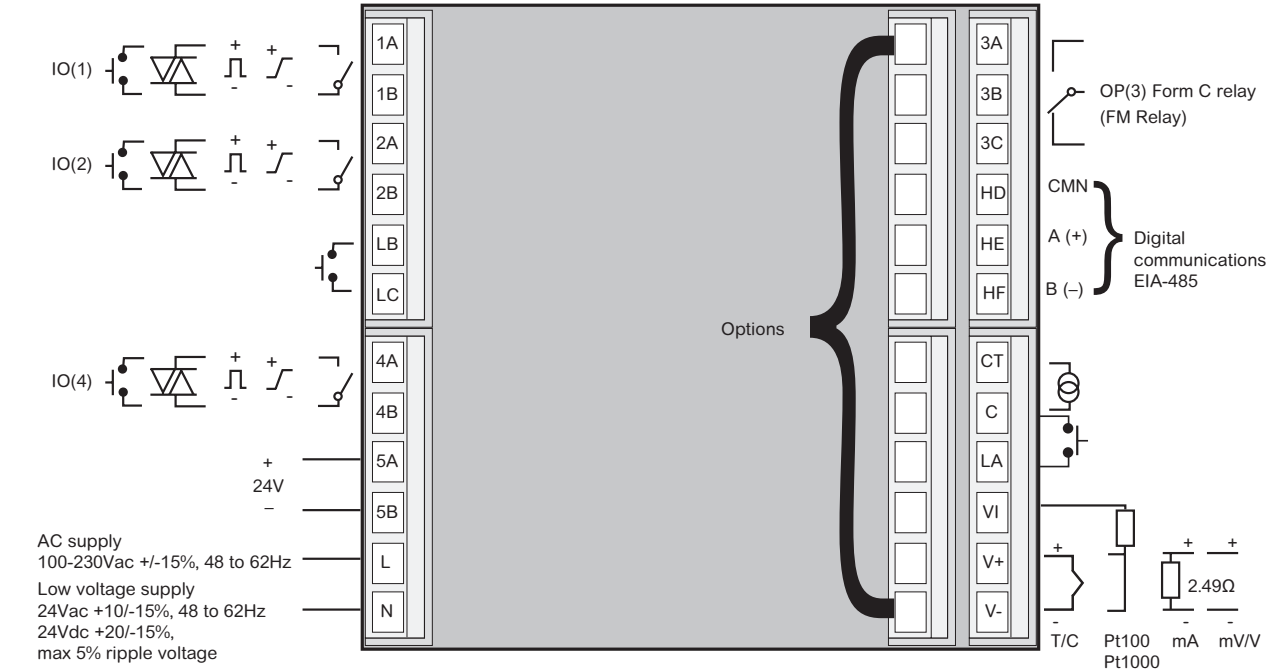

Key to Symbols Used in Wiring Diagrams

	Logic Output (SSR drive)		Relay Output		Contact Input
	0-10V/0-20mA Analog Output		TRIAC Output		Current Transformer Input

Specifications

Order codes EPC3016

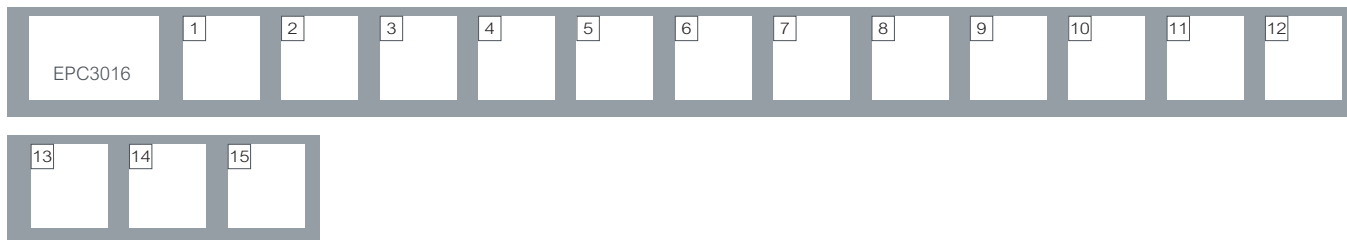

Model	
EPC3016	1/16 DIN Controller
Note	Includes one Universal PV Input and one Form C Relay

1	Type
CC	Controller Only
CP	1 x 8 Segment Basic Programmer
P1	1 x 24 Segment Advanced Programmer
P10	10 x 24 Segment Advanced Programmer
P20	20 x 8 Segment Advanced Programmer
FM	Factory Mutual Hi or Lo Limit Function
Note	The EPC3000 FM version uses main PV input and fixed Form C Relay 3 as the FM relay. No other hardware options are required, however they may be added for non-FM functions.

2	Supply Voltage
VH	100 - 230Vac +/-15% (48 to 62Hz)
VL	24Vac +10%, -15% (48 to 62 Hz); 24Vdc +20, -15%; 5% Ripple

3	I/O 1
XX	Not Fitted
L2	Logic
R1	Relay Output (Without Snubber)
R2	Relay (Supplied With External Snubber)
D1	DC Output
T1	TRIAC (Without Snubber)
T2	TRIAC (Supplied With External Snubber)

4	I/O 2
XX	Not Fitted
L2	Logic
R1	Relay Output (Without Snubber)
R2	Relay (Supplied With External Snubber)
D1	DC Output
T1	TRIAC (Without Snubber)
T2	TRIAC (Supplied With External Snubber)

5	Future
X	Not Fitted

6	Future
XX	Future

7	Serial Communications Protocol
XX	Modbus Slave (Default) Or None
EI	EI-Bisynch Comms
SM	Modbus Master and Slave
Note	Use of a serial communications protocol requires purchase of "C1", "C2" or "C3" option in field 8.

8	Ethernet, Communications & Remote SP
XX	None (Default)
C1	CT Input, Contact Closure Digital Input, and EIA-232
C2	CT Input, Contact Closure Digital Input, and EIA-485 (3 Wire)
C3	EIA-422 Only (5 Wire)
CR	CT Input, Contact Closure Digital Input, RSP Input
CE	Contact Closure Digital Input, Ethernet

9	Ethernet (TCP) Communications Protocol
XX	Modbus TCP Slave (Default) Or None
ES	EtherNet/IP Server and Modbus TCP Slave
BS	BACnet Slave and Modbus TCP Slave
TM	Modbus TCP Master and Slave
Note	Use of an ethernet communications protocol requires purchase of "CE" in field 8.

10	Tool Kit Blocks
XX	None (Default 50 Wires)
TK	Standard (Includes 200 Wires)
ETK	Enhanced (Includes 200 Wires)

11	OEM Security
XXX	None (Default)
OEM	OEM Security

12	Bezel
ST	Standard
WD	Washdown

13	Labels
XXXXX	None (Default)
Fnnnn	Custom Label

14	Specials
XXXXXX	None (Default)

15	Gain scheduling Sets
XX	Two Gain Scheduling Sets (Default)
08	Eight Gain Scheduling Sets

Quick start codes EPC3016



16 Application	
X	None
1	Heat Only
2	Heat/Cool
V	VPU
H	FM Hi Limit Function
L	FM Lo Limit Function
Note	Options, "1", "2" and "V" are available only if the "Type" (Field 1) is not set to "FM". Options "H" and "L" are only available for the FM Type.

17 Input 1 Sensor Type	
X	Not Required
M	Linear 0 to 80mVdc
V	Linear 0 to 10Vdc
2	Linear 0 to 20mA
4	Linear 4 to 20mA
B	Type B Thermocouple
J	Type J Thermocouple
K	Type K Thermocouple
L	Type L Thermocouple
N	Type N Thermocouple
R	Type R Thermocouple
S	Type S Thermocouple
T	Type T Thermocouple
P	Pt100
W	Pt1000

18 Input 1 Range	
X	Not Required
F	Full Range
1	0 to 100°C or 32 to 212°F or 273 to 373K
2	0 to 200°C or 32 to 392°F or 273 to 473K
3	0 to 400°C or 32 to 752°F or 273 to 673K
4	0 to 600°C or 32 to 1112°F or 273 to 873K
5	0 to 800°C or 32 to 1472°F or 273 to 1073K
6	0 to 1000°C or 32 to 1832°F or 273 to 1273K
7	0 to 1200°C or 32 to 2192°F or 273 to 1473K
8	0 to 1300°C or 32 to 2552°F or 273 to 1573K
9	0 to 1600°C or 32 to 2912°F or 273 to 1873K
A	0 to 1800°C or 32 to 3272°F or 273 to 2073K

19 Future	
X	Future

20 Future	
XX	Future

21 CT Input Range	
X	Not Used
1	10A
2	25A
5	50A
6	100A
7	1000A

22 Digital Input A Function (See Note 1)	
X	Not Used
W	Alarm Acknowledge
M	Auto/Manual
R	Programmer Run/Hold
L	Keylock
K	Loop Track
P	Local Setpoint Select
T	Programmer Reset
U	Remote Setpoint Select
V	Recipe Select
Note	Requires purchase of Communications Option (Field 8) with "Digital Input".

23 Future	
XX	Future

24 Future	
XX	Future

25 Units	
X	Use Default (Degrees Celsius)
C	Degrees Celsius
F	Degrees Fahrenheit
K	Kelvin

26 Future	
XX	Future

27 Warranty	
XX	Standard Warranty

28 Certificate of Conformity	
XX	None Required
CERT1	Supplied With Certificate of Conformity

Accessory order codes

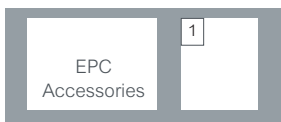

Model	
EPCACC	EPC Accessories

1 Accessories	
RES2R9	2.49Ω Resistor
RES250	250Ω Resistor
RES500	500Ω Resistor
SNUBBER	RC SNUBBER
USBCONF	USB Backup Lead
CTR10A	Current Transformer 10A Primary
CTR25A	Current Transformer 25A Primary
CTR50A	Current Transformer 50A Primary
CTR100A	Current Transformer 100A Primary
ITOOLS	iTools configuration Software

Order codes EPC3008/EPC3004

EPC3008 EPC3004	1	2	3	4	5	6	7	8	9	10	11	12
	13	14	15									

Model	
EPC3008	1/8 DIN Controller
EPC3004	1/4 DIN Controller
Note	I/O supplied as standard includes one Universal PV Input, EIA-485 Modbus RTU Slave Communications, 1 Form C Relay, 2x Contact Closure Digital Inputs, 1 Current Transformer Input, and 24Vdc Transmitter Power Supply.

1 Type	
CC	Controller Only
CP	1 x 8 Segment Basic Programmer
P1	1 x 24 Segment Advanced Programmer
P10	10 x 24 Segment Advanced Programmer
P20	20 x 8 Segment Advanced Programmer
FM	Factory Mutual Hi or Lo Limit Function
Note	Basic FM unit uses main PV input and fixed Form C Relay 3 as the FM relay. No other hardware options are required, however they may be added for non-FM functions.

2 Supply Voltage	
VH	100 - 230Vac +/-15% (48 to 62Hz)
VL	24Vac +10%, -15% (48 to 62 Hz); 24Vdc +20, -15%; 5% Ripple

3 I/O 1	
XX	Not Fitted
L2	Logic
R1	Relay Output (Without Snubber)
R2	Relay (Supplied With External Snubber)
D1	DC Output
T1	TRIAC (Without Snubber)
T2	TRIAC (Supplied With Snubber)

4 I/O 2	
XX	Not Fitted
L2	Logic
R1	Relay Output (Without Snubber)
R2	Relay (Supplied With External Snubber)
D1	DC Output
T1	TRIAC (Without Snubber)
T2	TRIAC (Supplied With External Snubber)

5 I/O 4	
XX	Not Fitted
L2	Logic
R1	Relay Output (Without Snubber)
R2	Relay Output (Supplied With External Snubber)
D1	DC Output
T1	TRIAC (Without Snubber)
T2	TRIAC (Supplied With External Snubber)

6 Future	
XX	Future

7 Serial Communications Protocol	
XX	Modbus Slave (Default)
EI	EI-Bisynch Comms
SM	Modbus Master and Slave
Note	EIA-485 serial communications is provided as standard for EPC3008 and EPC3004. No additional option purchase is required to use serial communications protocols.

8 Ethernet, Communications & Remote SP	
XX	None (Default)
I8	Second PV Input; 8 Digital Input/Outputs
D8	8 Digital Input/Outputs Only
E4	Ethernet (Modbus TCP Slave) 4 x Digital I/O Only
IE	Second PV Input; Ethernet (Modbus TCP Slave) + 4 x Digital I/O
Note	Digital I/O on Ethernet, 2nd Input & Option I/O cannot be used for PID control output.

9 Ethernet (TCP) Communications Protocol	
XX	Modbus TCP Slave (Default) or None
ES	EtherNet/IP Server and Modbus TCP Slave
BS	BACnet Slave and Modbus TCP Slave
TM	Modbus Master and Slave
Note	Use of Ethernet communications protocols requires purchase of Ethernet Communications (field 8) options "E4" or "IE".

10 Tool Kit Blocks	
XX	None (Default 50 Wires)
TK	Standard (Includes 200 Wires)
ETK	Enhanced (Includes 200 Wires)

11 OEM Security	
XXX	None (Default)
OEM	OEM Security

12 Bezel	
ST	Standard
WD	Washdown

13 Labels	
XXXXX	None (Default)
Fnnnn	Custom Label

14 Specials	
XXXXXX	None (Default)

15 Gain scheduling Sets	
XX	Two Gain Scheduling Sets (Default)
08	Eight Gain Scheduling Sets

Quick start codes EPC3008/EPC3004

16	17	18	19	20	21	22	23	24	25	26	27	28
----	----	----	----	----	----	----	----	----	----	----	----	----

16 Application	
X	None (Exit Quick Code)
1	Heat Only (Default) 1,2,V,C,D all add (note 5)
2	Heat/ Cool
V	VPU Heat Only
C	Carbon Potential Controller (Requires PV2 and Zirconia)
D	Dew Point Controller (Requires PV2 and Zirconia)
H	FM Hi Limit Function
L	FM Lo Limit Function
Note	Options, "1", "2", "V", "C" and "D" are available only if the "Type" (Field 1) is not set to "FM". Options "H" and "L" are only available for the FM Type..

17 Input 1 Sensor Type	
X	Not Required
M	Linear 0 to 80mVdc
V	Linear 0 to 10Vdc
2	Linear 0 to 20mA
4	Linear 4 to 20mA
B	Type B Thermocouple
J	Type J Thermocouple
K	Type K Thermocouple
L	Type L Thermocouple
N	Type N Thermocouple
R	Type R Thermocouple
S	Type S Thermocouple
T	Type T Thermocouple
P	Pt100
W	Pt1000

18 Input 1 Range	
X	Not Required
F	Full Sensor range
1	0 to 100°C or 32 to 212°F or 273 to 373K
2	0 to 200°C or 32 to 392°F or 273 to 473K
3	0 to 400°C or 32 to 752°F or 273 to 673K
4	0 to 600°C or 32 to 1112°F or 273 to 873K
5	0 to 800°C or 32 to 1472°F or 273 to 1073K
6	0 to 1000°C or 32 to 1832°F or 273 to 1273K
7	0 to 1200°C or 32 to 2192°F or 273 to 1473K
8	0 to 1300°C or 32 to 2552°F or 273 to 1573K
9	0 to 1600°C or 32 to 2912°F or 273 to 1873K
A	0 to 1800°C or 32 to 3272°F or 273 to 2073K

19 Input 2 Sensor Type	
X	Not Required
M	Linear 0 to 80mVdc
V	Linear 0 to 10Vdc
2	Linear 0 to 20mA
4	Linear 4 to 20mA
B	Type B Thermocouple
J	Type J Thermocouple
K	Type K Thermocouple
L	Type L Thermocouple
N	Type N Thermocouple
R	Type R Thermocouple
S	Type S Thermocouple
T	Type T Thermocouple
P	Pt100
W	Pt1000
Z	Zirconia (HiZ)
Note	Requires purchase of second input (field 8). either "I8" or "IE".

20 Input 2 Range (See note 7)	
X	Not Required
F	Full range
1	0 to 100°C or 32 to 212°F or 273 to 373K
2	0 to 200°C or 32 to 392°F or 273 to 473K
3	0 to 400°C or 32 to 752°F or 273 to 673K
4	0 to 600°C or 32 to 1112°F or 273 to 873K
5	0 to 800°C or 32 to 1472°F or 273 to 1073K
6	0 to 1000°C or 32 to 1832°F or 273 to 1273K
7	0 to 1200°C or 32 to 2192°F or 273 to 1473K
8	0 to 1300°C or 32 to 2552°F or 273 to 1573K
9	0 to 1600°C or 32 to 2912°F or 273 to 1873K
A	0 to 1800°C or 32 to 3272°F or 273 to 2073K
Note	Requires purchase of second input (field 8), either "I8" or "IE".

21 CT Input Range	
X	Not Used
1	10A
2	25A
5	50A
6	100A
7	1000A

22 Digital Input A Function	
X	Not Used
W	Alarm Acknowledge
M	Auto/Manual
R	Programmer Run/Hold
L	Keylock
K	Loop Track
P	Local Setpoint Select
T	Programmer Reset
U	Remote Setpoint Select
V	Recipe Select

23 Digital Input B Function	
X	Not Used
W	Alarm Acknowledge
M	Auto/Manual
R	Programmer Run/Hold
L	Keylock
K	Loop Track
P	Local Setpoint Select
T	Programmer Reset
U	Remote Setpoint Select
V	Recipe Select

24 Programmer I/O Configuration	
X	Not Used/Fitted
1	D1 to D8 Programmer Event Outputs 1 to 8
2	D1 to D4 = Programmer Event Outputs 1 to 4, D5 to D7 = BCD Inputs 1 to 3, D8 = Programmer Run/Hold. BCD Output to Program Number
3	D1 to D4 = Programmer Event outputs 1 to 4, D5 to D8 Programmer Run, Hold, Reset, Advance Respectively
4	D1 to D4 = Programmer Event inputs 1 to 4, D5 to D7 Programmer Run/Hold, Reset, Advance Respectively, D8 Not Used. BCD Output to Program Number
5	D1 to D8 = BCD Inputs 1 to 8. BCD Output to Recipe Recall
6	D1 to D4 = BCD Inputs 1 to 4, D5 - D8 = Not used. BCD Output to Recipe Recall
7	D1 to D4 Programmer Run, Hold, Reset, Advance Respectively, D5 - D8 = Not used
8	D1 to D3 Programmer Run, Hold, Reset Respectively, D4 - D8 = Not Used
9	D1 to D4 = Programmer Event Outputs, D5 to D8 = Not Used
Note	Requires purchase of option I/O (field 8). either "I8", "D8", "E4" or "IE". Not available for EPC3000 FM versions.

25 Units	
X	Use Default (Degrees Celsius)
C	Degrees Celsius
F	Degrees Fahrenheit
K	Kelvin

26 Future	
XX	Future

27 Warranty	
XX	Standard Warranty

28 Certificate of Conformity	
XX	None Required
CERT1	Supplied With Certificate of Conformity

Your Authorized Distributor is:



ZESTA
Industrial Thermal Technologies

ZESTA ENGINEERING LTD.
212 Watline Avenue
Mississauga ON, L4Z 1P4

1-800-755-5418 ▪ www.zesta.com ▪ info@zesta.com

Mississauga, ON ▪ Montréal, QC ▪ Calgary, AB ▪ Vancouver, BC

Eurotherm Headquarters

Faraday Close, Worthing
West Sussex BN13 3PL
United Kingdom
Phone: +44 (0) 1903 268500

www.eurotherm.com



Watlow, Eurotherm, EurothermSuite, EFit, EPack, EPower, Eycon, Chessell, Mini8, nanodac, piccolo and versadac are trademarks and property of Watlow its subsidiaries and affiliated companies. All other trademarks are the property of their respective owners.