



## POWER SERIES Controllers



## Watlow® POWER SERIES™ Controllers Provide Microprocessor-Based SCR Power Control Designed for Application Flexibility

Watlow® has manufactured solid state power controllers for over fifty years. Watlow's POWER SERIES™ is a microprocessor-based product that features application flexibility unmatched by any other silicon controlled rectifier (SCR) power controller on the market today. Watlow's POWER SERIES controllers include single and three-phase models from 65 to 250 amperes. Field configurable phase-angle or zero-cross firing improves application flexibility on site where needed.

50/60Hz independent operation allows utilization almost everywhere in the world without special calibration considerations. Serial communication via Modbus® RTU allows setup and monitoring of load status from a computer station or control room.

On-board semiconductor fusing improves reliability by protecting the SCRs from heater short circuits. Plus, on-board heater bakeout and control diagnostics can help eliminate initial start up problems. All these benefits are in a touch-safe package that can be quickly and easily mounted in a control cabinet.

Watlow's POWER SERIES controllers are UL® and C-UL® listed, ensuring that they meet world safety and operational standards.

### Features and Benefits

#### 200KA short circuit current rating (SCCR)

- Minimizes damage in the event of a short circuit

#### Microprocessor-based technology

- Extremely versatile and field configurable

#### Snap-fit on a pre-mounted plate

- Simplifies installation

#### Models 65 through 250 amperes rating

- Handles a wide range of loads

#### UL® 508 listed, C-UL® and CE with filter

- Meets applications requiring agency approval

#### Adjustable soft start

- Provides application flexibility

#### Heater and control diagnostics capability

- Monitors actual heater and controller performance

#### Electrically touch-safe package

- Enhances safety for installer and users

#### Serial communications with Modbus® RTU protocol

- Provides computer control and/or monitoring

#### Multizone capability

- Increases application flexibility and reduces panel space

ISO 9001



## Specifications

### Power Bases

- Single-phase, (2 SCRs)
- 3-phase, 2-leg control, (4 SCRs)  
Resistive load only, zero-cross firing only
- 3-phase, 3-leg control, (6 SCRs)
- 3-phase, 3-leg control, (6 SCRs) for 4-wire wye loads
- Multizone, two and three single-phase zones

### Output Control Options

- Zero-cross control, fixed time base
  - Time base one or four seconds with digital programmer
- Zero-cross control, variable time base
- Phase-angle control and phase-angle control with current limit (not for 3-phase, 2-leg models)
  - Soft start factory default four seconds upon power-up, and adjustable from 0.0 to 120 seconds
  - Soft start upon input signal change, output rate of change adjustable to limit max. rate of change from 0.1 to 100% per 0.1 second. Factory default 10%
- Current transformer included when required
- Line voltage compensated (variable time base and phase angle controllers only)
- Standby or non-operational mode

### Output Voltage and Current Rating

- 24 to 120VAC (+10%, -15%)
- 200 to 480VAC (+10%, -15%)
- 200 to 600VAC (+10%, -15%)
- 65 through 250A per pole, model dependent; see Output Amperage Chart
- Min. load 1A rms ac
- Max. leakage current 5mA
- 200KA SCCR, Type 2 approved with the recommended fusing; see user manual

### Alarms

- Single alarm relay
- Latching or non-latching
- Separate high and low values
- Alarm silencing (inhibit) on power up for alarm
- Alarm indication LEDs, shorted SCR, open heater, fuse
- Electromechanical relay, Form C contact, software configurable
  - Min. load current 10mA @ 5VDC
  - Rated resistive loads: 3A @ 250VAC or 30VDC max., inductive load rating 1.5A with a power factor  $\geq 0.4$  without contact suppression

### Heater Bakeout

- For single-phase (phase to neutral) and 3-phase 6 SCR models only (not for 3-phase, 2-leg models)
- Soft start with over current trip, runs until programmed bakeout time expires, then goes burst or phase-angle firing. Factory default of 24 hours
- Adjustable 0 - 9999 minutes with over-current trip
- Internal current transformer included

### Command Signal Input

#### Analog

- Input signal: field selectable and scalable, 0 to 20mA or 0 to 10VDC
- Default input signal: 4 to 20mA
- Manual control input via digital programmer/display
- Voltage input impedance 11k $\Omega$  nominal
- Current input impedance 100 $\Omega$  nominal

#### Digital

- On-board digital programmer/display and optional serial communications

#### Retransmit

- Field selectable and scalable, 0 to 20mA with 800 $\Omega$  max. load or 0 to 10VDC with 1K $\Omega$  min. load
- Default: 4 to 20mA
- Resolution:  
mA ranges =  $\pm 5\mu\text{A}$   
VDC ranges = 2.5mV nominal

- Calibration accuracy:  
mA ranges =  $\pm 20\mu\text{A}$   
VDC ranges = 10mV nominal
- Temperature stability: 100ppm/ $^{\circ}\text{C}$

### Digital Programmer/Display and Communications Capabilities

- Programming functions
  - Adjust input and output control type, alarms and soft start, heater bakeout and current limit prompts
- Monitoring functions
  - Display input and output values along with actual output current
- Data retention of digital programmer/display upon power failure via nonvolatile memory

### Serial Communications

- RS-232 for single drop control
- EIA-485 for single or multidrop control
  - 32 units maximum can be connected. With additional 485 repeater hardware, up to 247 units may be connected
- Isolated
- Modbus<sup>®</sup> RTU protocol
- 1200, 2400, 4800, 9600, 19200 baud rates

### Controller Power Supply

- Universal line voltage input range 100 to 240VAC (+10%, -15%) at 55VA max.
- 50/60Hz  $\pm 5\%$  line frequency independent
- Controller line voltage for electronic power supply can be run on separate line voltage

### Natural Convection and Fan Cooled Models

- Cabinet venting may be required
- See Amperage Chart with Ordering Information for available configurations

### Power Dissipation (Watts)

- Approximately 1.25 watts/amperes per controlled leg

### Isolation

- Command signal to load and line/load to ground 2200VAC min.
- On-board semiconductor fuses provide SCR protection

### Mounting

- Output Amperage Rating F35: back panel
- Other Output Amperage Ratings: removable mounting plate

### High Current Terminals

- Touch safe
- $\frac{3}{8}$  in. (10 mm) Allen head compression terminals will accept 6 AWG to 350 MCM wire. Allen wrench adapter (included) for  $\frac{3}{8}$  in. (10 mm) socket, 6 point only
- Torque to 180 in.-lbs (20.3 Nm)
- Wire strip to  $1\frac{1}{8}$  in. (30 mm)
- Requires 194 $^{\circ}\text{F}$  (90 $^{\circ}\text{C}$ ) wire insulation rating on line and load terminals

### Controller Terminals

- Touch safe
- $\frac{1}{8}$  in. (2.5 mm) blade screwdriver, accepts 12-22 AWG or 2 ea. 22-18 AWG wires
- Torque to 8 in.-lbs (0.9 Nm)
- Wire strip to 0.24 in. (6 mm)

### Operating Environment

- 122 $^{\circ}\text{F}$  (50 $^{\circ}\text{C}$ ) base rating
  - 32 to 140 $^{\circ}\text{F}$  (0 to 60 $^{\circ}\text{C}$ ) fan cooled
  - 32 to 149 $^{\circ}\text{F}$  (0 to 65 $^{\circ}\text{C}$ ) natural convection cooled
- 0 to 90% RH, non-condensing
- Meets EN50178, Pollution degree three

### Storage Temperature

- -40 to 185 $^{\circ}\text{F}$  (-40 to 85 $^{\circ}\text{C}$ )

### Shipping Weight

- Output Amperage Rating F35: 38 lbs (17.2 kg)
- Other Output Amperage Ratings: 23 lbs (10.3 kg)

### Agency Approvals

- UL<sup>®</sup> 508 listed, File #E73741, Vol. 3, Sec. 2
- C-UL<sup>®</sup> listed to C22.2 NO. 14
- CE 2004/08/EC (EN61326-1), Class A with filter, CE 2006/95/EC (EN50178)

## Dimensions (Output Amperage Ratings: N20, N25, N30, F20, F25 or F30)

Front View

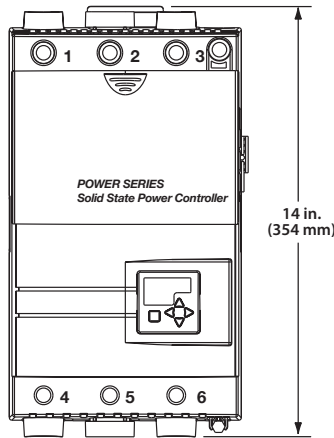

Top View

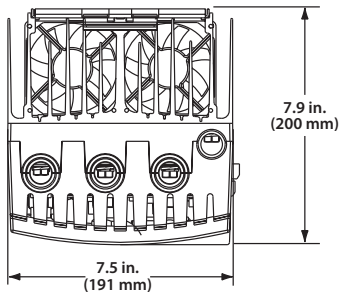

Mounting Plate

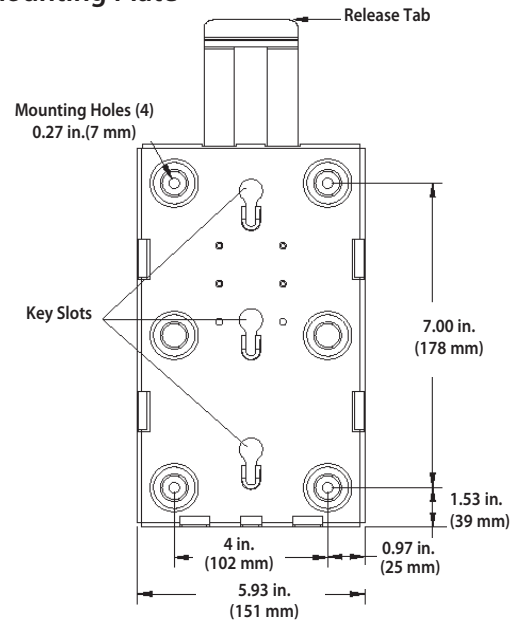

## POWER SERIES Features

**Removable Mounting Plate**  
Power Series snaps on a pre-mounted, removable subplate.

**Terminal Cover**  
Electrically touch-safe package.

**Fuse Cover**  
Slides up and down for fuse maintenance and covers the high voltage components.

**Digital Programmer/Display**  
For controller configuration, setup and monitoring features.

**Ground Lug**  
Built in, designed for easy ground connections.

**I/O Port**  
Input, retransmit output, communications and alarms.

**On-Board Fan**  
A fan is integrated into the package on forced air cooled models to eliminate separate power connection for fan.

**Allen Wrench**  
Used to torque terminals one to six and ground lug.

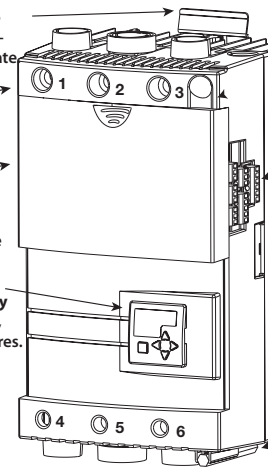

## Dimensions (Output Amperage Rating: F35)

Bottom View

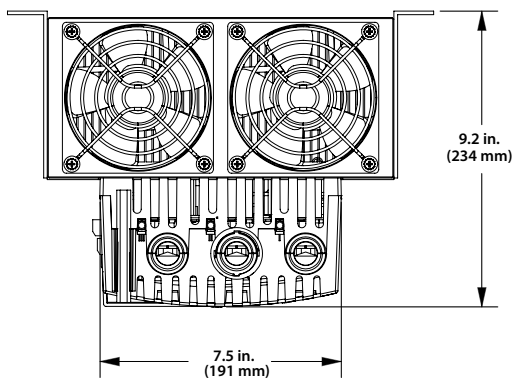

Front View

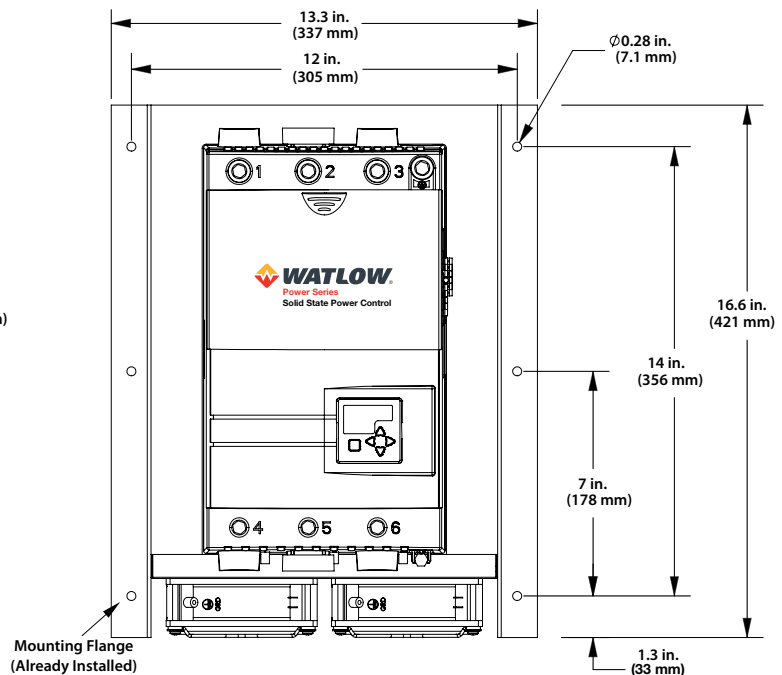

## Ordering Information

### Part Number

① ②	③	④	⑤ ⑥ ⑦	⑧	⑨	⑩	⑪ ⑫
<b>PC</b>	Phase	Heater Diagnostics	Output Amperage Rating	Output Voltage Rating	Comm.	Feedback/Retransmit	Custom

②	<b>Package Style</b>
C =	65 to 250A

③	<b>Phase</b>
1 =	1-phase
2 =	3-phase/2-leg control, (4 SCRs)
3 =	3-phase/3-leg control, (6 SCRs)
4 =	3-phase/4-wire, wye connected load
8 =	2 single-phase zones (specify 01 or 03 for custom)
9 =	3 single-phase zones (specify 01 or 03 for custom)

④	<b>Heater Diagnostics (Includes Current Limit)</b>
0 =	None
1 =	Heater diagnostics (Current limiting and heater bakeout are only available on single-phase and 3-phase, 3-leg controllers)

⑤ ⑥ ⑦	<b>Output Amperage Rating</b>
See amperage chart below.	

⑧	<b>Output Voltage Rating</b>
A =	24 to 120V
B =	200 to 480V
C =	200 to 600V

⑨	<b>Communications</b>
0 =	None
1 =	EIA/TIA-232/485 communications, opto-isolated, (field selectable)

⑩	<b>Feedback/Retransmit</b>
0 =	None
1 =	Load current feedback (0-10V or 0-20mA scalable retransmit output) (Must have heater diagnostics selected)

⑪ ⑫	<b>Custom</b>
00 =	None
AA =	No Watlow logo with agency approval marks
AB - ZZ =	Custom, contact your Watlow representative for options
01 =	Select for PC8 or PC9 using single-phase power supply, Watlow logo
03 =	Select for PC8 or PC9 using multi-phase power supply, Watlow logo

### Single-Phase Configuration

This configuration can be purchased with any or all the features available on the POWER SERIES, based on customer preference. It is intended for resistive heaters, but can also be used on transformer connected loads in the phase angle firing mode.

### Three-Phase, Two Leg Configuration

This configuration is intended for zero cross firing only into a stable resistive heater. Typically, a three-phase delta or ungrounded wye connected heater is used and only two of the three VAC line phases are switched. The third phase is a direct connection through a bussbar on board the POWER SERIES. Heater current monitoring and kVA options are available via the heater diagnostics option.

### Three-Phase, Three-Leg Configuration

All POWER SERIES options are available with this configuration. It works well with phase angle firing into a three-phase, three-wire wye or delta connected heater. In this configuration, the more common applications are transformer connected loads with heaters requiring a soft start and/or current limiting.

The three-phase, four-wire configuration is intended for zero cross firing into a three-phase grounded wye/star heater (This is a separate hardware option, model number dependent.)

### Single-Phase, Multizone Configuration

This configuration is available in two and three single-phase zones and all the features of a single-phase unit are available. (Note that there is only one alarm relay and all zones in the controller must use the same control method.)

### Heater Diagnostics

Heater diagnostics may include some or all of the features that require heater current monitoring, depending on the model selected. Heater current monitoring is only available with heater diagnostics installed on the controller. The features dependent on heater current monitoring are heater bakeout, current limiting, heater kVA monitoring, retransmit and heater monitoring alarms such as open heater, heater out of tolerance, load balance and shorted SCR detection/error. Heater diagnostics must also be installed if you need phase angle control with current limit.

## Amperage Chart—122°F (50°C)

	Single-Phase		3-Phase, 2-Leg and 2 Single-Phase Zones		3-Phase, 3-Leg, 3 Single-Phase Zones and 4-Wire Model	
	Code	Amp	Code	Amp	Code	Amp
Non Fan Cooled	N20	100A	N20	80A	N20	65A
	N25	140A	N25	105A	N25	85A
	N30	165A	N30	120A	N30	105A
Fan Cooled	F20	125A	F20	120A	F20	90A
	F25	200A	F25	160A	F25	140A
	F30	250A	F30	185A	F30	155A
	N/A	N/A	F35	250A	F35	225A

**Note:** For current ratings at other temperatures see the rating curves in the POWER SERIES User's Manual available at [www.watlow.com](http://www.watlow.com).

## Powered by Possibility

To be automatically connected to the nearest North American Technical Sales Office:

**1-800-WATLOW2 • [www.watlow.com](http://www.watlow.com)  
inquiry@watlow.com**

### International Technical Sales Offices:

**China** +86 21 3532 8532  
**France** +33 1 41 32 79 70  
**Germany** +49 7253 9400 0  
**India** +91 40 6661 2700

**Italy** +39 02 4588841  
**Japan** +81 3 3518 6630  
**Korea** +82 2 2169 2600  
**Mexico** +52 442 256 2200

**Singapore** +65 6773 9488  
**Spain** +34 91 675 1292  
**Taiwan** +886 7 288 5168  
**UK** +44 115 964 0777