

Strip/Clamp-On Heaters

Mineral Insulated (MI) Strip Heaters

The MI strip heater is a thin, responsive heater that uses the most advanced heater construction techniques. A nickel-chromium element wire is embedded in Watlow's exclusive mineral insulation material, which has a much higher thermal conductivity than the mica and hard ceramic insulators used in conventional heaters. This thin layer of insulation brings the element wire closer to the heater sheath. The result is heat flows easily from the element wire to the sheath allowing the wire to run cooler than conventional heaters and increasing heater life.

Performance Capabilities

- Sheath temperatures up to 1400°F (760°C)
- Watt densities up to 140 W/in² (21.7 W/cm²)
- Maximum voltage up to 480VAC
- UL® component recognition for most 240VAC or less designs (UL® File #E52951)

Features and Benefits

Higher watt densities than any other strip heater

- Provides faster heat up

Exclusive mineral insulation

- Combines dielectric strength and superior thermal conductivity
- Transfers heat rapidly to the sheath

304 stainless steel sheath

- Maintains the high compaction of mineral insulation
- Produces a rigid heater

Typical Applications

- Solder pots
- Zinc die-casting equipment
- Die and mold heating
- High-temperature resins
- Tank and platen heating
- Ovens
- Packaging equipment

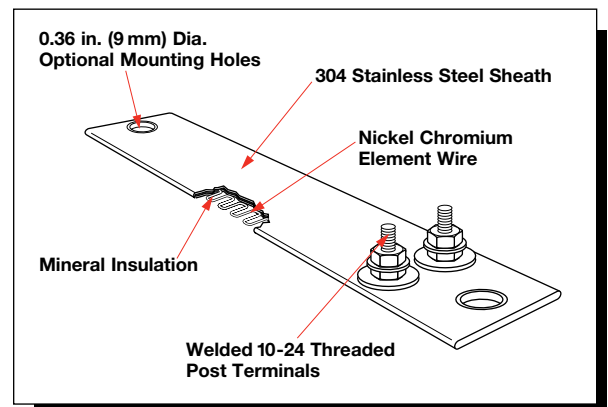
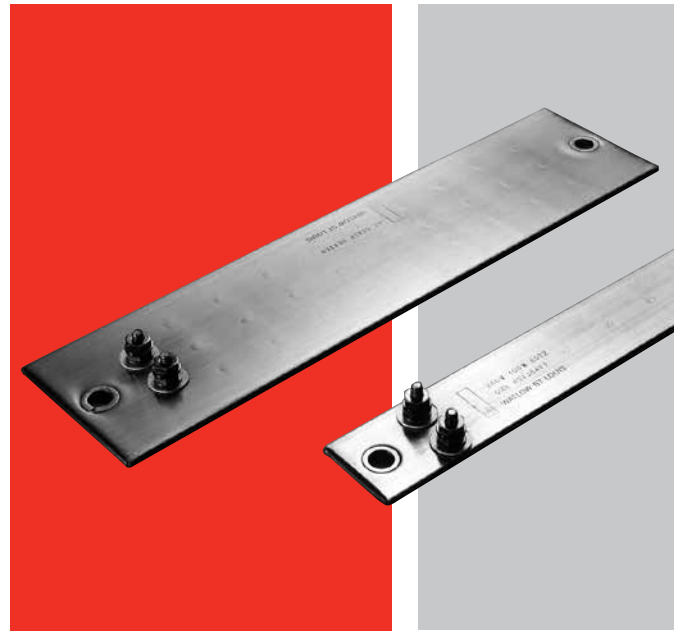

RAPID SHIP

- Next day shipment

Strip/Clamp-On Heaters

Mineral Insulated (MI) Strip Heaters

Applications and Technical Data

Calculating Watt Density

Watt density is the amount of wattage per square inch of heated area. To determine watt density, divide the total wattage by the heated area.

$$\text{Watt Density} = \frac{\text{Wattage}}{\text{Heated Area}}$$

To apply this equation, the heated area is the total contact surface of the heater less areas of no-heat found around terminals, mounting holes, etc.

Heated Area = Total Contact Area - No-Heat Area

To calculate the heated area:

- Using the chart below, locate the **no-heat factor** corresponding to the type of heater being considered.
- To use the formula below, insert the no-heat factors, length and width (in inches).

$$\text{Heated Area} = (\text{Overall Length} - \text{No-Heat Factor}) \times \text{Width}$$

Type	No-Heat Factor (in.)
1 in. Wide	
1 in. wide post terminal 1 on 1	1.75
1 in. wide post terminal 1 on 1 with mounting holes	3.00
For all other widths	
2 on 1 post terminal	1.18
2 on 1 with mounting holes	3.18

The drawings on the next page and the graph on this page will help in selecting the correct watt density for a particular application. First, refer to the drawings to determine the heated area of the heater. Then, use the

watt density formula and graph to ensure that the maximum watt density of the heater does not exceed the specific application requirements.

$$\text{Watt Density} = \frac{\text{Wattage}}{\text{Heated Area}}$$

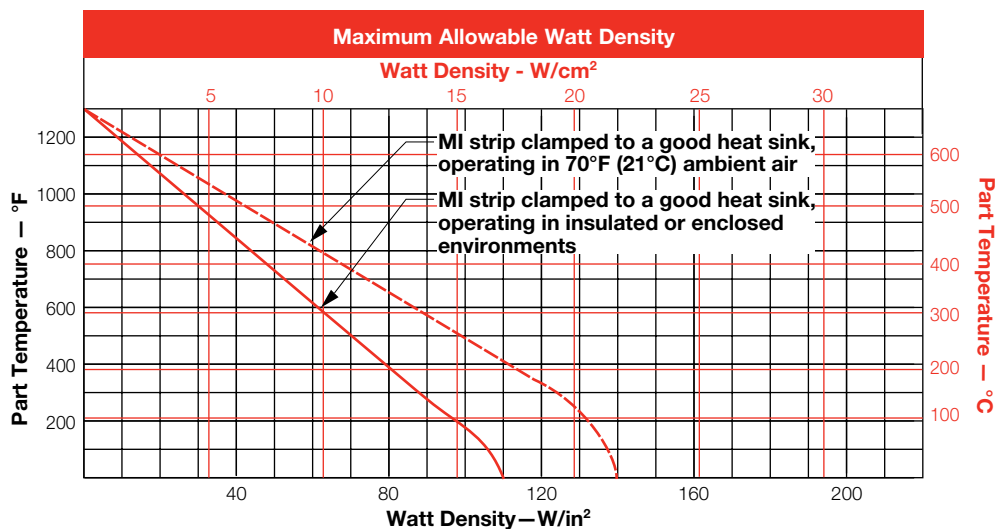

Strip/Clamp-On Heaters

Mineral Insulated (MI) Strip Heaters

Applications and Technical Data (Continued)

Specifications

Width

- 1, 1½ and 2 in. (25, 38, 51 mm), tolerance $\pm 1/32$

Length

- 8 to 30 in. (203 to 762 mm), tolerance $\pm 1/8$

Terminations

- 1 in. (25 mm) wide—post terminals one-on-one
- 1½ to 2 in. (38 to 51 mm)—post terminals two-on-one

All Widths

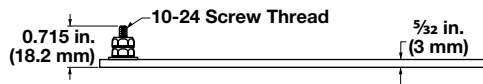

Note: In most applications, mounting holes alone do not provide adequate clamping. A clamp bar should be used for each 4 in. (102 mm) of heater length.

1 in. (25 mm) Wide

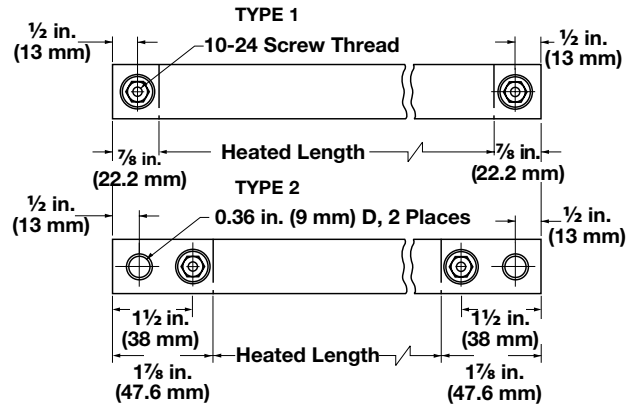

1½ in. – 2 in. (38 – 51 mm) Wide

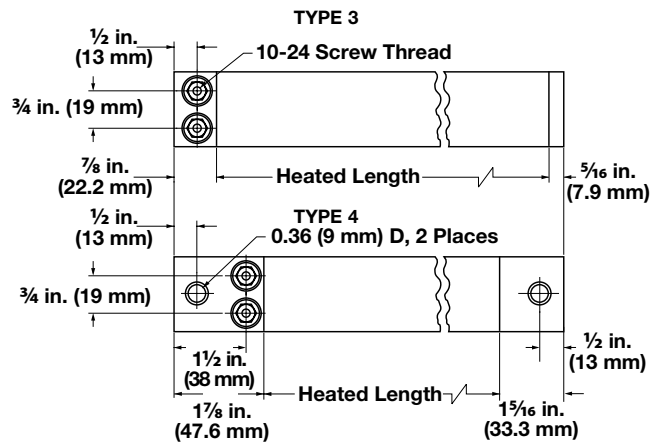

Strip/Clamp-On Heaters

Mineral Insulated (MI) Strip Heaters

Applications and Technical Data (Continued)

Options

Thermocouple Pocket

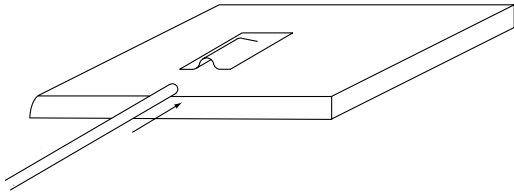

A thermocouple pocket welded to the back surface accepts a 0.063 in. (1.6 mm) diameter thermocouple. This option provides accurate temperature sensing and easy thermocouple replacement. Thermocouple not included.

Accessories

Ceramic Terminal Covers

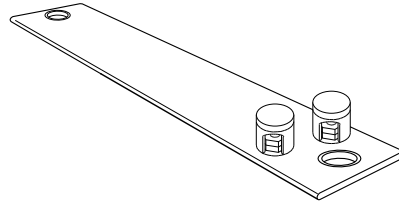

Ceramic terminal covers offer a convenient and economic method to insulate post terminals. They are sized for standard length posts with 10-24 screw thread size, supplied as an accessory item and shipped separately. Specify Z4918 and quantity.

Parallel Terminals Part Numbers—Type 3 and 4

Width in. (mm)	Length in. (mm)	Volts	Power (Watts)	Watt Density W/in ² (W/cm ²)	Approx. Net Wt. lbs. (kg)	Type	Part Number
1 1/2 (38)	8 (203)	240	500	50 (7.8)	0.3 (0.15)	3	MS1J8AS3
1 1/2 (38)	12 (305)	120	350	26 (4.0)	0.5 (0.2)	4	MS1J12AV2^①
1 1/2 (38)	12 (305)	240	350	26 (4.0)	0.5 (0.2)	4	MS1J12AV3^①
1 1/2 (38)	12 (305)	240	800	49 (7.6)	0.5 (0.2)	3	MS1J12AS2
1 1/2 (38)	18 (457)	120	1000	40 (6.2)	0.8 (0.3)	3	MS1J18AS1
1 1/2 (38)	18 (457)	240	1000	40 (6.2)	0.8 (0.3)	3	MS1J18AS2

^① Denotes units with mounting holes. Mounting holes are 0.36 in. (9 mm) in diameter and are intended for use with 1/4 in. (6 mm) bolts.

Centers of mounting holes are located 1/2 in. (13 mm) from the ends of the heater.

RAPID SHIP

- Next day shipment up to 5 pieces